





HEKMAN

ASSEMBLY INSTRUCTIONS

24303-End Table Planked Top

A HOWARD MILLER COMPANY

HARDWARE LIST

NO.	DESCRIPTION	SKETCH	DIMENSION	Q'TY
1		ALLEN KEY	5MMxL75mm	1pc
2		SPRING WASHER	Ø5/16"	16 pcs
3		FLAT WASHER	Ø5/16"(19mm)	16 pcs
4		BOLT	Ø5/16"x 19mm	16 pcs
5		BOLT	Ø5/16"x 16mm	8 pcs

STEP 1 On a clean surface assemble the metal end frames and metal stretchers with Bolt #5 and Lock washer #2, With Allen wrench #1

STEP 2 Assemble shelf With Bolts #4, Lock washer #2, and Flat washer #3, Do not fully tighten Bolts until Step 5.

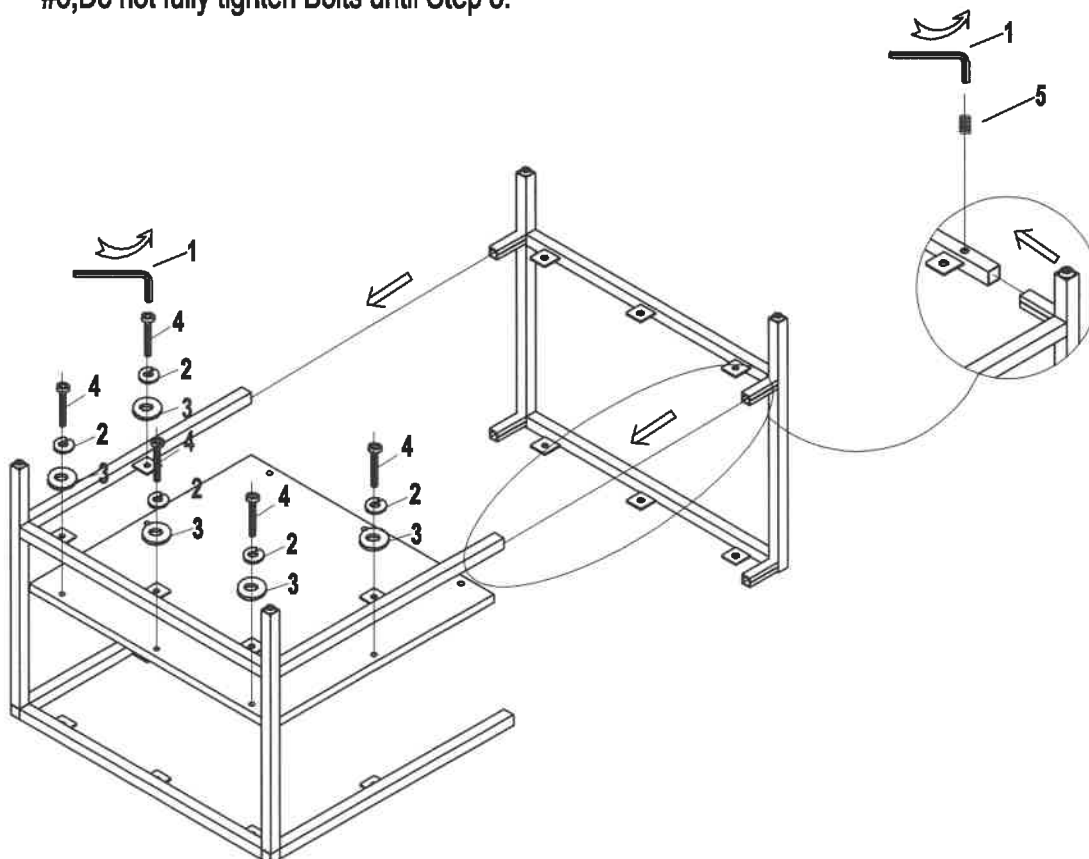

MADE IN VIETNAM

HEKMAN

ASSEMBLY INSTRUCTIONS

24303-End Table Planked Top

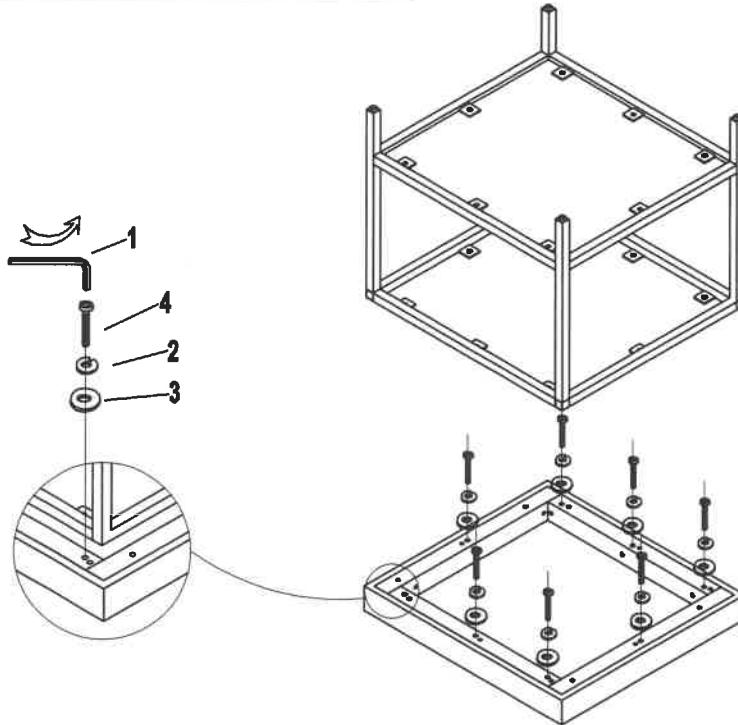

STEP 3 Lay Top Panel Face Down on a soft clean surface.

STEP 4 Attach metal Base shelf to the top panel with Bolt #5, Lock washer #2, and Flat washer #3

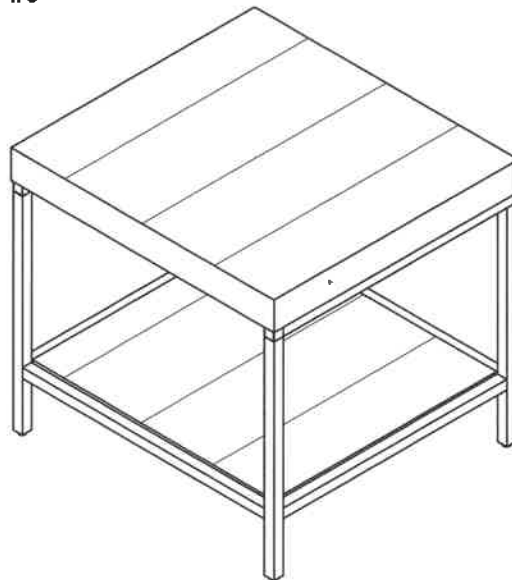

STEP 5 Tighten all Bolts with Allen Wrench #1

STEP 6 Turntable Upright,

MADE IN VIETNAM