

303-200 Series

Heavy Duty Push-to-Open 100 lb Full Extension
Side Mount Ball Bearing Slides

Installation Instructions



Parts Included:

2 pcs Drawer slides
16 pcs Installation screws

Tools Required:

Pencil
Phillips Screwdriver
Drill with 1/8" drill bit
Level
Tape Measure

Cabinet & Drawer Requirements:

Side Clearance:

Measure the width of the opening and the width of the drawer box. **Opening – Drawer = 1" to 1-1/16"**

7/32" to 1/2" of clearance between the width of the cabinet space and the drawer per slide is required for installation.

! If the drawer box is not within these parameters, the drawer slide will not function correctly.



Cabinet and Drawer Measurements:

Ensure that the cabinet and drawer are both square by measuring the distance from the front of each side to the back of the opposite side of both the cabinet and drawer.

The maximum difference is 1/16".

! If the difference is greater than 1/16" the slide will not work correctly.

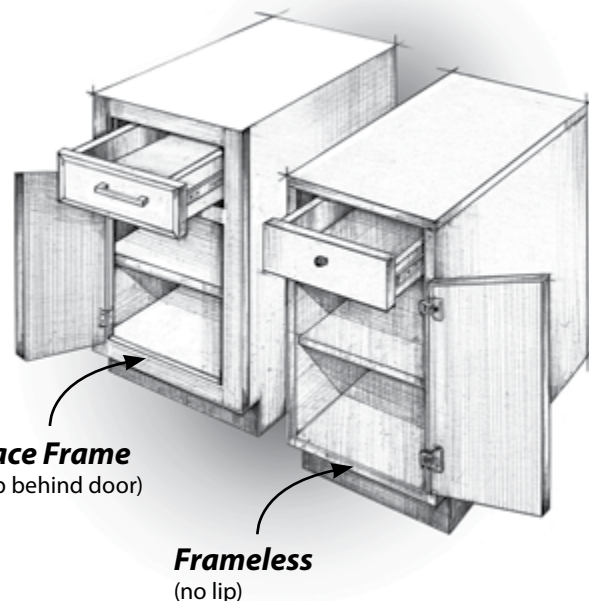
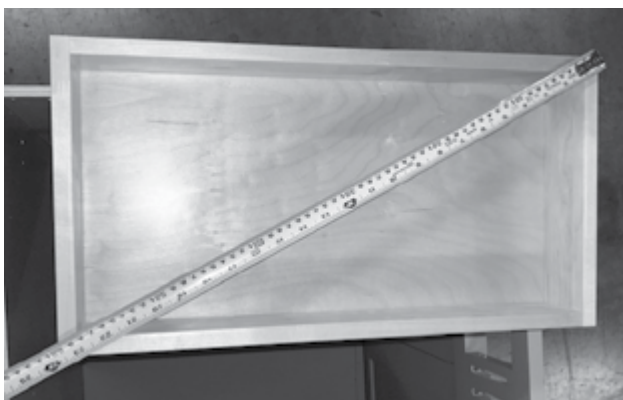

You will also need:

Rear Mounting and Face Frame Brackets



Rear Brackets (2)
Item 303FUSFT2 - sold separately

Cabinets with a Face Frame

Cut a cleat board for mounting brackets

1. Measure the drawer opening width.
Opening + 1/8" = Cleat Board Width



2. Cut a board measuring about 2" tall by the width just calculated.
! This board can be made from any wood that is between 1/4" to 1" thick. We recommend plywood or 1x4 boards.
3. Fasten Rear Brackets flush to the outer edges and bottom of the cleat using the horizontal slotted adjustment hole and one #6 x 1/2" screw per bracket (supplied).
! Avoid stripping out screws by not overtightening.
! Fasten screws loosely to allow the brackets to adjust when the drawer is first installed. You will tighten them in the last step.



Install cleat board in cabinet

4. Measure the distance from the top of the drawer rail to the top of the cabinet and subtract the piece of wood height (2") from the measurement.
5. Use this measurement to position the top of the cleat board to the rear of your cabinet.
 - ! If using optional Face Frame Bracket, mount rear bracket cleat board 1/2" higher to account for the change to the cabinet member location.
6. Center and level the cleat board at the rear of the cabinet and fasten to the cabinet with your own screws.

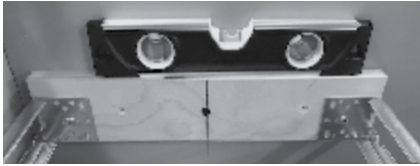

Install slide in cabinet

7. Separate the cabinet and drawer member of the slide by pressing the non-handed tripper disconnect then pulling the two members apart.
 - ! Take note of how the slides are oriented, which will be necessary when reassembling the slide.
 - ! The smaller section that was just removed is the drawer member and the section with the two sliding pieces is the cabinet member.

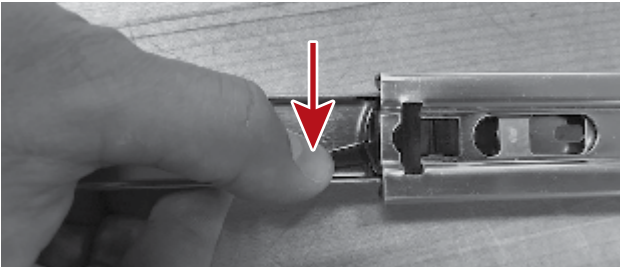

8. Slide the back of the cabinet member into the brackets you installed on your cleat board.



9. Line the front of the slide up with the edge of the face frame. Using the front hole of the cabinet member, predrill a hole using a 1/8" drill bit. Secure each cabinet member to the face frame of the cabinet using one #6 x 1/2" screw (included) per side.



10. Align the Face Frame Bracket with the front edge of the face frame and attach using one #6 x 5/8" screw (included).
11. Insert slide cabinet member into rear bracket and Face Frame Bracket until the cabinet member snaps into the bracket and will not slide forward.
 - ! Rear bracket cleat board must be mounted 1/2" higher to account for the change to the cabinet member location.
 - ! Additional side clearance required when using Face Frame Bracket. Measure the width of the opening and the width of the drawer box.
Opening - Drawer = 1-1/8" to 1-3/16"

Install slide to drawer

12. For Inset application, no special installation required. For Overlay application, allow 1/8" clearance for push-to-open mechanism. Opens drawer approximately 2" from closed position. Great for clean-line drawers without hardware and for commercial cabinetry.
 - ! Ensure the drawer members are parallel to bottom of drawer box for optimal performance.

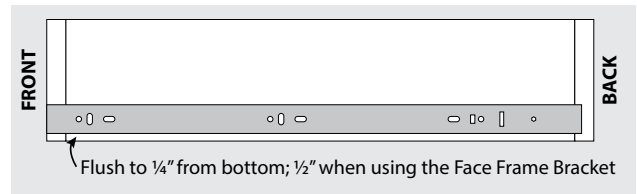

Install drawer in cabinet

13. Before installing the drawer to the cabinet, ensure that the ball bearing cage is located to the front of the cabinet member as shown below. Failure to do so may damage the cabinet member.
 - ! The built-in Cage Hold Forward simplifies this process.



14. Carefully insert the drawer members into the cabinet members and slide the drawer all the way back so that the drawer members are fully engaged.
15. Cycle the drawer all the way in and back out 4 or 5 times so that the rear brackets are adjusted.
16. Carefully remove the drawer once the brackets are adjusted and fully tighten screws. Add an additional fastener to each bracket using the small circular holes so the brackets do not move.



Frameless Cabinets

Install slide in cabinet

1. Separate the cabinet and drawer member of the slide by pressing the non-handed tripper disconnect then pulling the two members apart.

! Take note of how the slides are oriented, which will be necessary when reassembling the slide.

! The smaller section that was just removed is the drawer member and the section with the two sliding pieces is the cabinet member.

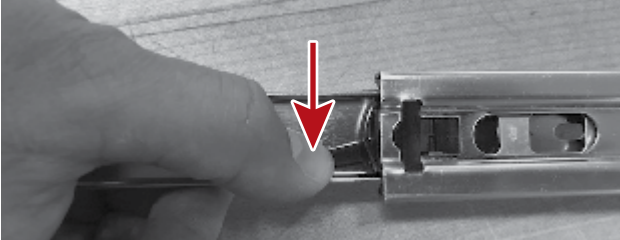

2. Measure from the top of the cabinet to the desired drawer location. Draw a level line on the inside of the cabinet where the top of the cabinet member will mount.



3. Use the line and a level to position the cabinet member to the side of the cabinet ensuring that the front of the member is flush with the front of the cabinet.



Install slide to drawer

4. Mount the drawer members to the drawer box sides flush with the front edge and between 1/4" and 1/2" from bottom edge depending on drawer height.

! Ensure the drawer members are parallel and level for optimal performance.

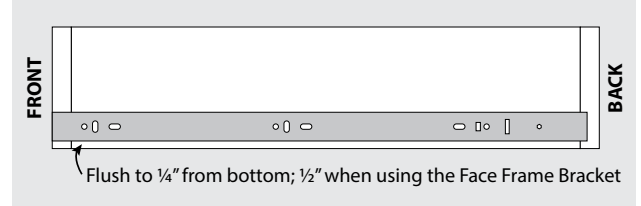

Install drawer in cabinet

5. Before installing the drawer to the cabinet, ensure that the ball bearing cage is located to the front of the cabinet member as shown below. Failure to do so may damage the cabinet member.

! The built-in Cage Hold Forward simplifies this process.

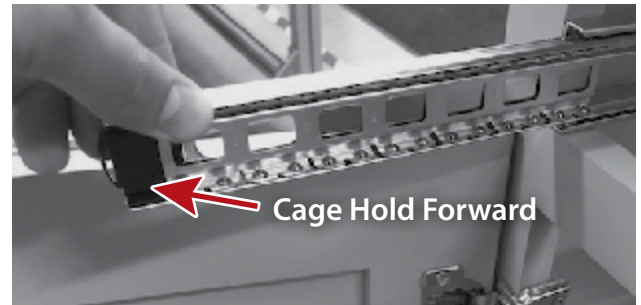

6. Carefully insert the drawer members into the cabinet members and slide the drawer all the way back so that the drawer members are fully engaged.
7. Cycle the drawer all the way in and back out 4 or 5 times so that the rear brackets are adjusted.

Hole pattern drawings

DRAWER MEMBER

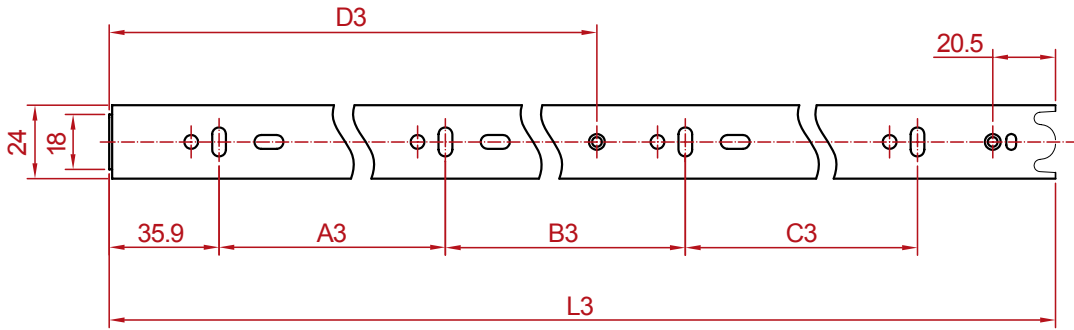

Specifications	L3	A3	B3	C3	D3
303-200-14 - 14"	338	128	128	-	255
303-200-16 - 16"	388	128	192	-	290
303-200-18 - 18"	438	160	192	-	320
303-200-20 - 20"	488	192	224	-	340
303-200-22 - 22"	538	224	224	-	365

all measurements shown in millimeters

CABINET MEMBER

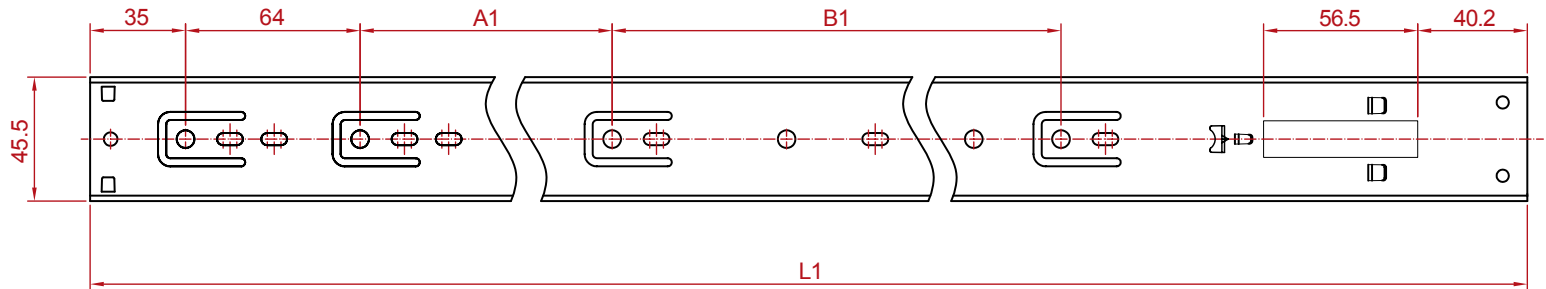

Specifications	L1	A1	B1
303-200-14 - 14"	350	96	-
303-200-16 - 16"	400	128	-
303-200-18 - 18"	450	160	-
303-200-20 - 20"	500	256	-
303-200-22 - 22"	550	288	-

all measurements shown in millimeters