





HEKMAN[®]

A HOWARD MILLER COMPANY

ASSEMBLY INSTRUCTION FOR 24940 DESK W/3 DRAWERS

HARDWARE LIST

NO.	ITEM	DESCRIPTION	QTY.
1		Bolt M8X25 MM	20
2		Flat washer M8X25 MM	20
3		NUT	8
4		Wrench	1

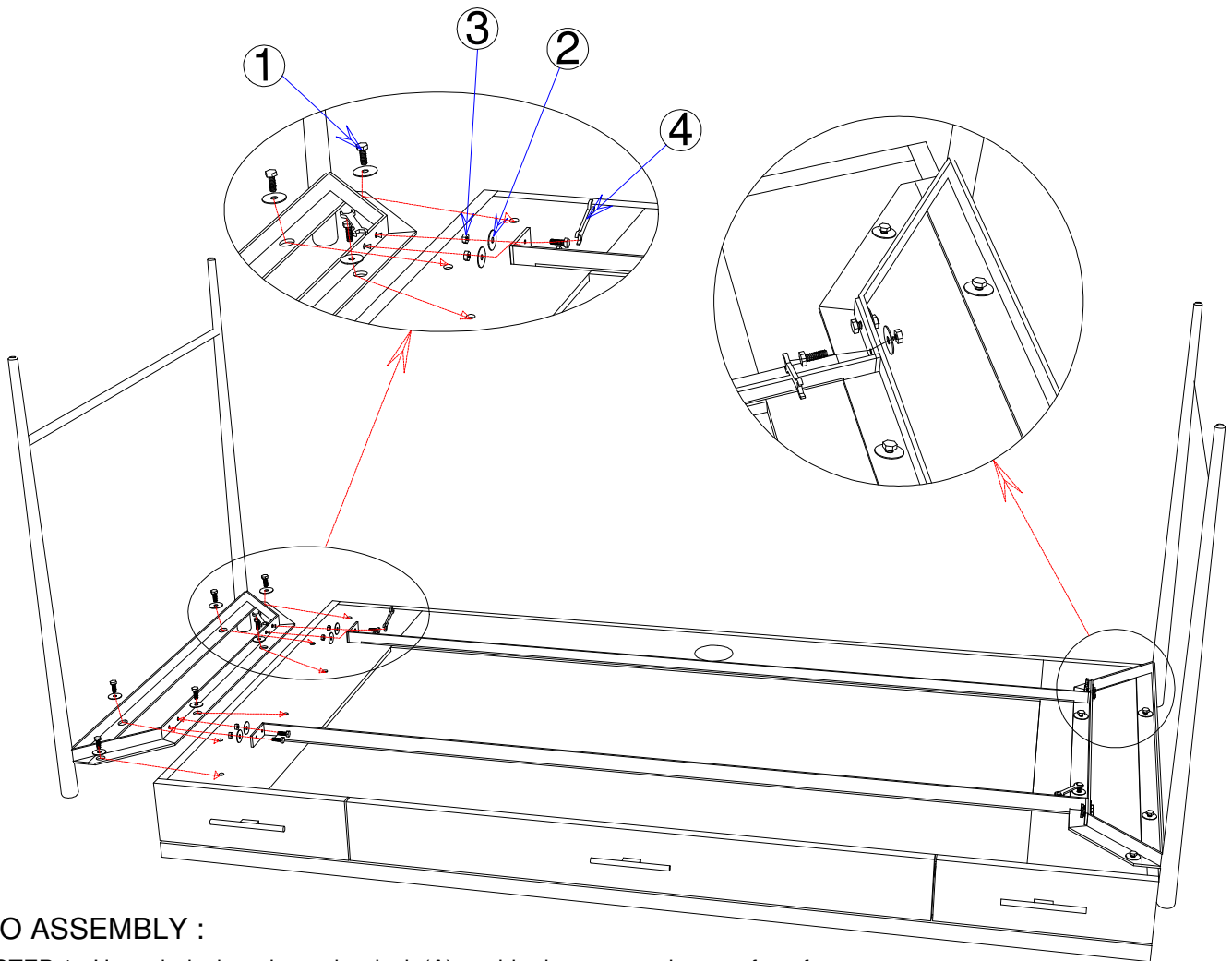
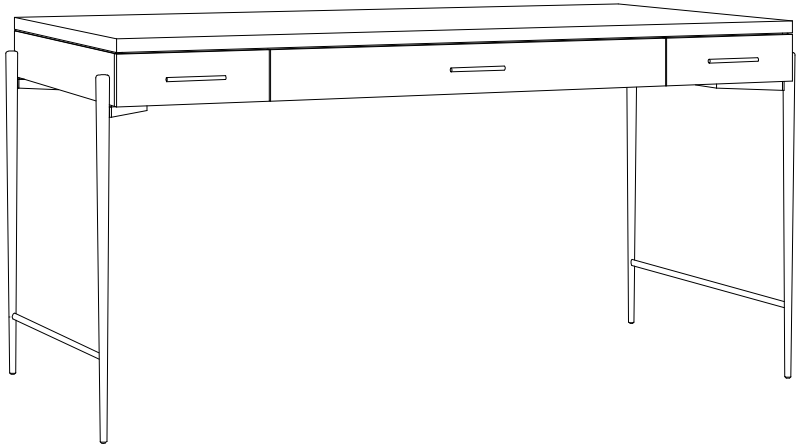

TO ASSEMBLY :

STEP 1 : Unpack desk and turn the desk (A) upside down. on a clean, soft surface.

STEP 2 : Match the iron legs(B). use matching marks A1 & B1 - on top (A).

STEP 3 : Align holes in legs (B) with holes on bottom of desk (A) and slide it into position.

STEP 4 : Thread the flat washer(2) , bolt (1) & nut (3) to leg (B) . Do not tighten bolts fully until all bolts have been started.

STEP 5 : Tighten bolts in step 4 fully with wrench (4) then carefully turn the desk upright.