

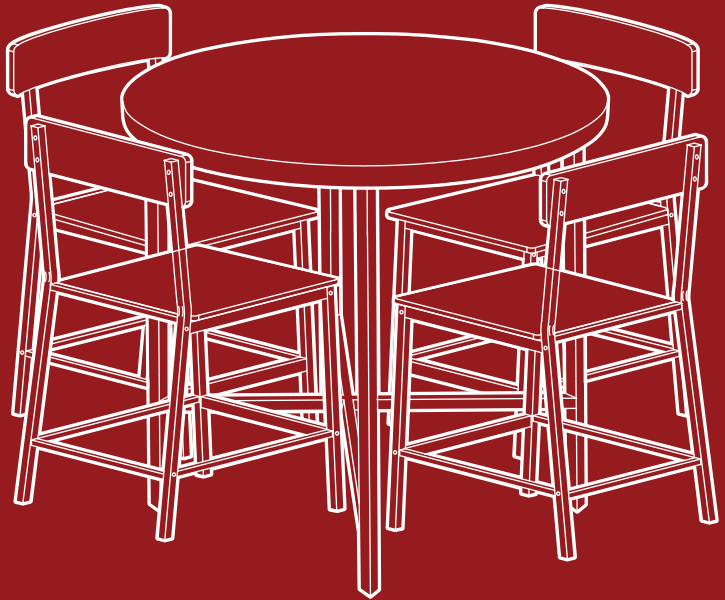

BEST CHOICE
PRODUCTS



INSTRUCTION MANUAL

5-Piece Counter Height
Dining Set

Ver. 2

SKY6562 + SKY6563 + SKY9427 + SKY9428 + SKY9429 + SKY9430

! NOTICE

Please retain these instructions for future reference.

- Please do not exceed the weight limitations of this item.
- Do not stand on or use any part of this item as a step ladder.
- Firmly secure all bolts, screws, or knobs before use.
- Reconfirm that all bolts, screws, or knobs are secure every 90 days.
- Fasten screws loosely during initial assembly. Do not firmly tighten the screws until the item is completely assembled.
- Do not use or store this item in the proximity of open flame or flammable/combustible chemicals.
- Be aware that some parts are heavy and have sharp edges.
- Assemble this item on a flat, level, and stable surface for an ideal construction.
- This product is intended for indoor use only.
- This product is intended for residential use only.
- If any parts are missing, broken, damaged, or worn, stop using this product until repairs are made and/or factory replacement parts are installed.
- Do not use this item in a way inconsistent with the manufacturer's instructions as this could void the product warranty.
- This product is intended for residential use only.

TOOLS REQUIRED



ALLEN WRENCH
(PROVIDED)



175 LBS
TABLE
CAPACITY



300 LBS
CHAIR
CAPACITY



2 PERSON
ASSEMBLY



UP TO 45 MIN.
ASSEMBLY

HARDWARE

1

M6 x 50mm
SCREW



12 PCS

2

M6 x 40mm
SCREW



48 PCS

3

M6 x 30mm
SCREW



16 PCS

PARTS

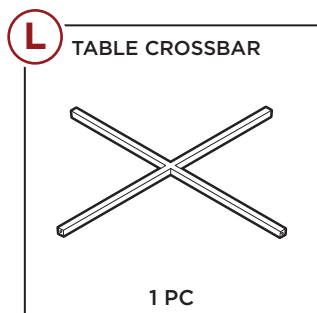
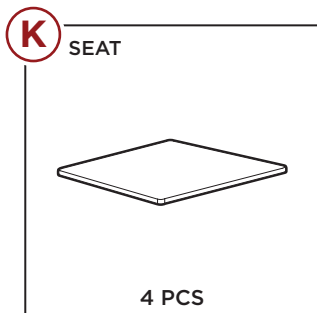
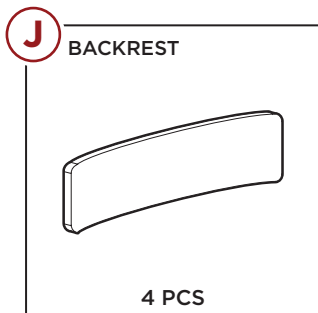
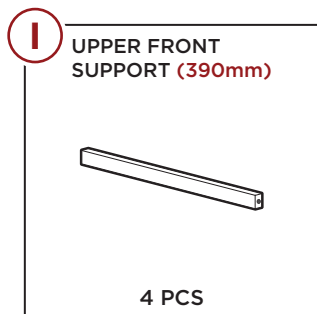
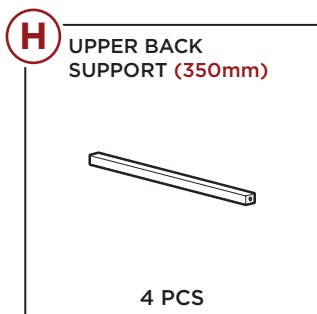
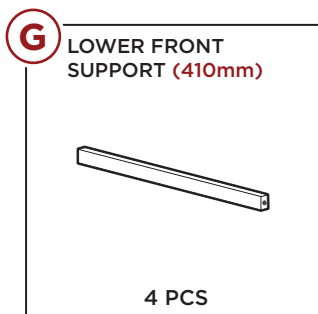
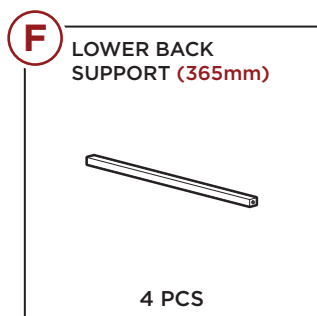
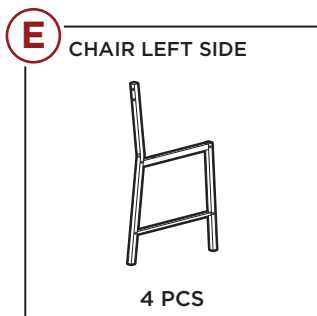
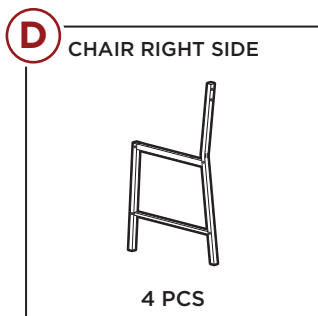
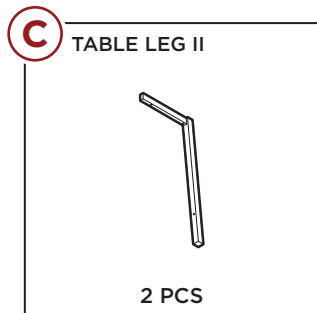
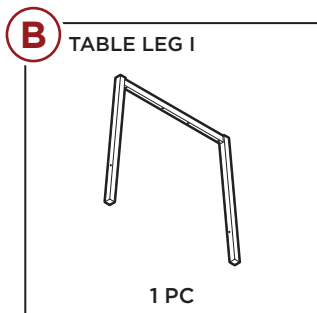
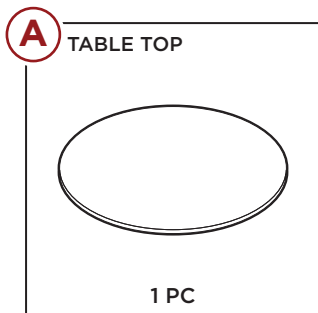

PRODUCT ASSEMBLY - TABLE

1

Place the **part A table top** on a flat level surface, its bottom facing upward, and attach the **part B table leg I** with four **part 1 screws**.

Attach two **part C table leg II** with four **part 1 screws**, two screws per leg.

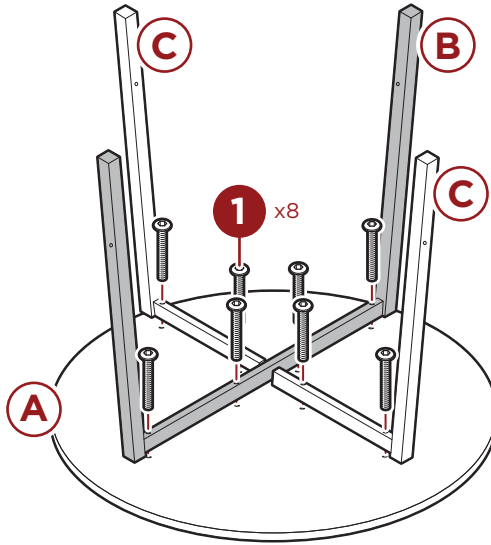

2

Attach the **part L table crossbar** to the table legs with four **part 1 screws**.

NOTE: The faces of the crossbar have two angles, place the longer angle/face closer to the bottom of the chair legs.

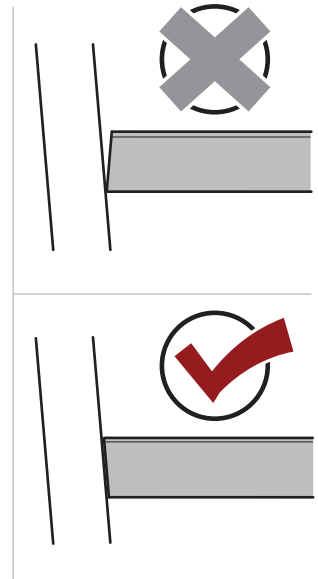
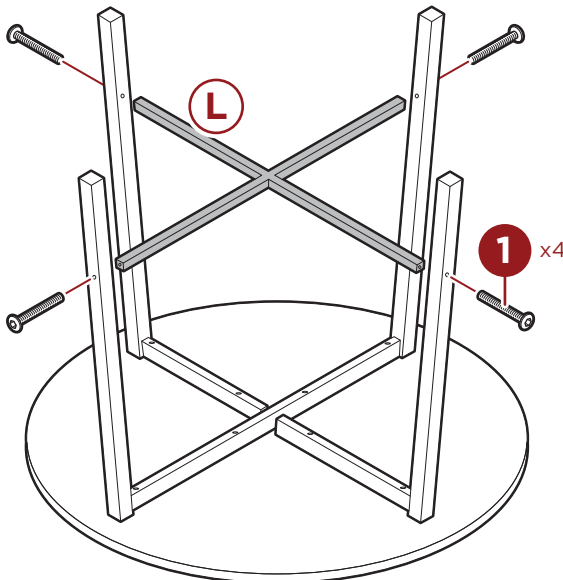

PRODUCT ASSEMBLY - CHAIR

1

Attach one **part H upper back support** and one **part F lower back support** to the **part E chair left side** with two **part 2 screws**.

NOTE: The faces of the supports have two angles, place the longer angle/face on the outer edge of the chair.

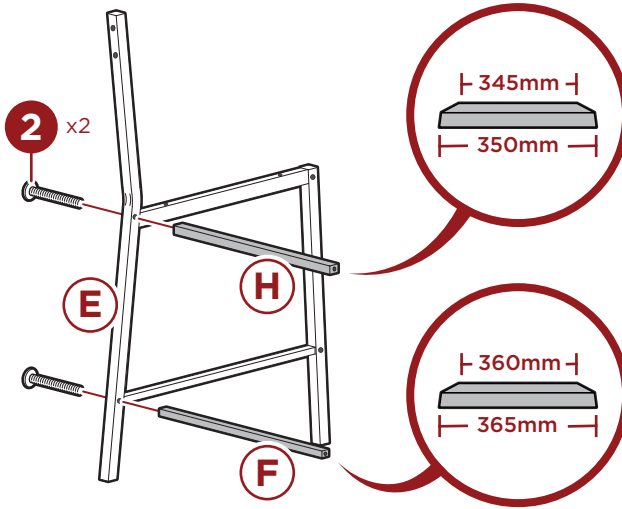

2

Attach one **part I upper front support** and one **part G lower front support** to the **part E chair left side** with two **part 2 screws**.

NOTE: The faces of the supports have two angles, place the longer angle/face on the outer edge of the chair.

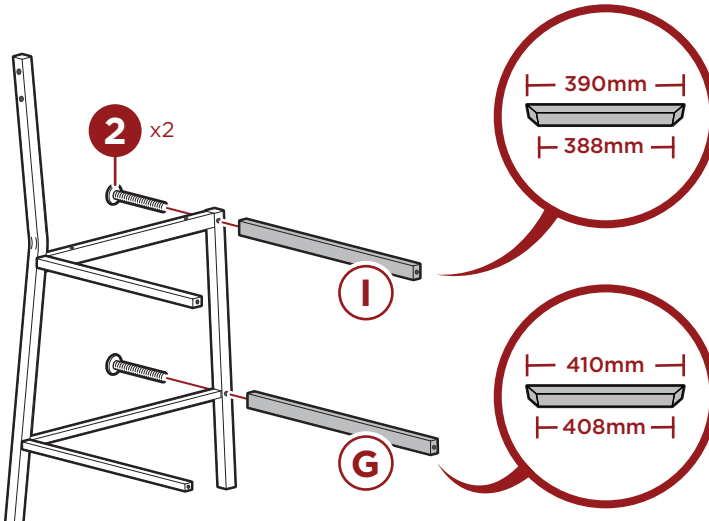

PRODUCT ASSEMBLY - CHAIR

3

Locate one **part D chair right side** and attach it to the chair assembly (see previous step) with four **part 2 screws**.

NOTE: If necessary, place the assembly on its side to complete step 3.

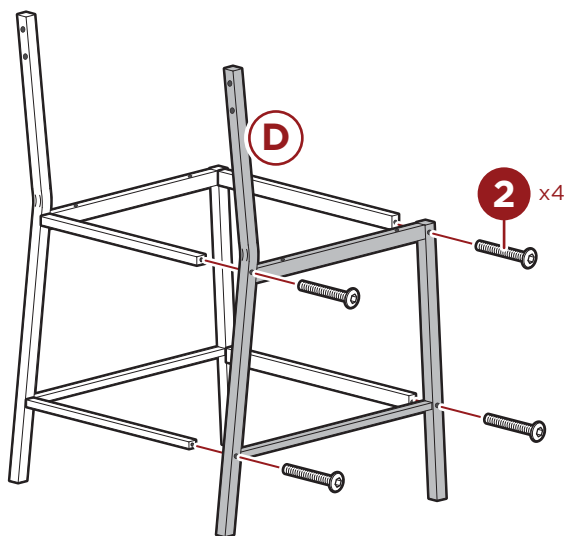

4

Attach the **part J backrest** to the **part D & E chair sides** with four **part 3 screws**.

Set the chair assembly with its bottom facing upward.

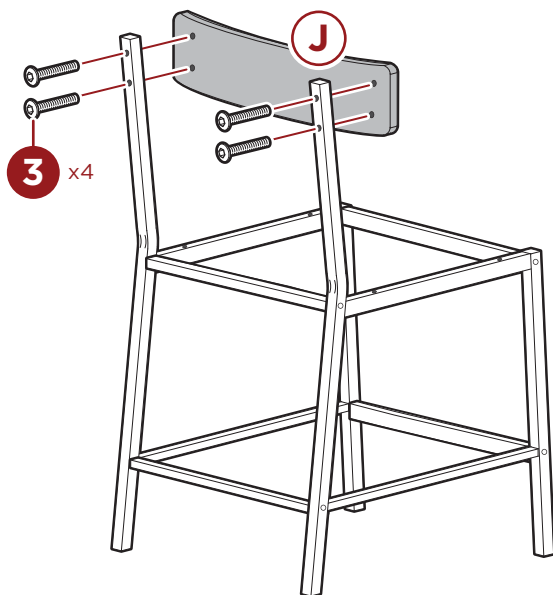

PRODUCT ASSEMBLY - CHAIR

5

Attach the **part K** seat to the **part D & E** chair sides with four **part 2** screws. Flip the assembly upright.

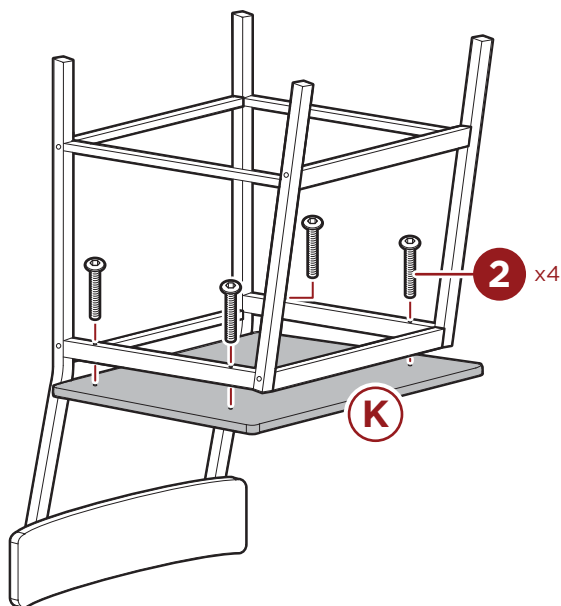

6

Repeat steps 1-5 to assemble three more chairs.





HELP CENTER



Question about your product? We're here to help. Visit us at:

help.bestchoiceproducts.com



Chat Support



Product Inquiry



Orders FAQ



Product Assembly



Returns & Refunds

PRODUCT WARRANTY INFORMATION

All items can be returned for any reason within 60 days of the receipt and will receive a full refund as long as the item is returned in its original product packaging and all accessories from its original shipment are included. All returned items will receive a full refund back to the original payment method. All returned items will not be charged a re-stocking fee.

All returned items require an RA (Return Authorization) number, which can only be provided by a Best Choice Products Customer Service Representative when the return request is submitted. Items received without an RA may not be accepted or may increase your return processing time. Once an item has been received by Best Choice Products, refunds or replacements will be processed within 5 business days.

All returns must be shipped back to the Best Choice Products Return Center at the customer's expense. If the reason for return is a result of an error by Best Choice Products then Best Choice Products will provide a pre-paid shipping label via email. Boxes for return shipping will not be provided by Best Choice Products, and is the customer's responsibility to either use the original shipping boxes or purchase new boxes.

Pictures may be required for some returns to ensure an item is not damaged prior to its return. Items returned are not considered undamaged until they are received by Best Choice Products and verified as such. All damages to items are the customer's responsibility until the item has been received by and acknowledged by Best Choice Products as undamaged.

© Best Choice Products, Inc. All rights reserved. Distributed by Best Choice Products, Inc. Newport Beach, CA 92660

WARNING

Manufacturer and seller expressly disclaim any and all liability for personal injury, property damage or loss, whether direct, indirect, or incidental, resulting from the incorrect attachment, improper use, inadequate maintenance, unapproved modification, or neglect of this product.