

Buffet



IMPORTANT

Carefully remove all the parts from the carton and place them individually on a soft cloth to prevent scratches or other damage.

Carefully and strictly follow these assembly instructions to ensure a completed product as designed.

Do not use power tools above 8 volts to assemble.

Part List

							G. Back Stretcher 1 pc.
A. Side Panel 1 pc.	B. Side Panel 1 pc.	C. Middle Panel 1 pc.	D. Middle Panel 1 pc.	E. Back Panel 3 pcs.	F. Back Upright 2 pcs.		H. Back Stretcher 1 pc.
							I. Front Stretcher 1 pc.
K. Front Upright 2 pcs.	L. Fixed Shelf 1 pc.	M. Base 1 pc.	J. Front Stretcher 1 pc.	N. Leg 2 pcs.	T. Drawer 3 pcs.	Refer to later page(s) of these instructions for drawer assembly.	
O. Wine Grid 2 pcs.	P. Wine Grid 2 pcs.	Q. Shelf 2 pcs.	R. Door 1 pc.	S. Door 1 pc.			

Hardware List

Hex Wrench 1 pc.	M6x35 Head Cap Bolt 4 pcs. (+1 extra)	Cam Lock 14 pcs. (+2 extra)	Cam Lock Screw 14 pcs. (+1 extra)	M3.5x13 Wood Screw (short) 12 pcs. (+1 extra)	M4x25 Machine Screw 8 pcs.	Knob 2 pcs.
Small Hex Wrench 1 pc.	M6x50 Head Cap Bolt (long) 8 pcs. (+1 extra)	Cross Dowel 8 pcs. (+1 extra)	M3.5x25 Wood Screw (long) 24 pcs. (+1 extra)	Adjustable Pin 8 pcs. (+2 extra)	M3.5x16 Wood Screw for Back Panel 12 pcs. (+1 extra)	Handle 3 pcs.

20 05100 Top carton is also needed for assembly.

Tool(s) required for assembly: Phillips screwdriver, Level, Drill (8 volts or less), 3/8" Drill Bit

Home Styles Customer Service: www.homestyles-furniture.com,
 servicedesk@homestyles-furniture.com, 888-680-7460, 877-831-0319

Assembly Instructions 2/8

IMPORTANT

- Use a soft cloth between these parts and the floor.
- Do not use power tools above 8 volts to assemble.
- Do not tighten all the bolts until each part is properly assembled.
- The unit must be level to work properly. Use the included adjustable levelers to level.
- Keep Hex Wrench as the bolts may need to be tightened in the future.

STEP 1

Insert Cam Lock Screws into pre-drilled holes in Side Panels (A), (B) and Middle Panels (C), (D), then tighten. (See Figure 1)

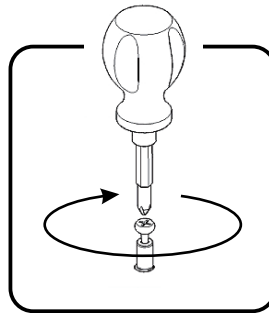
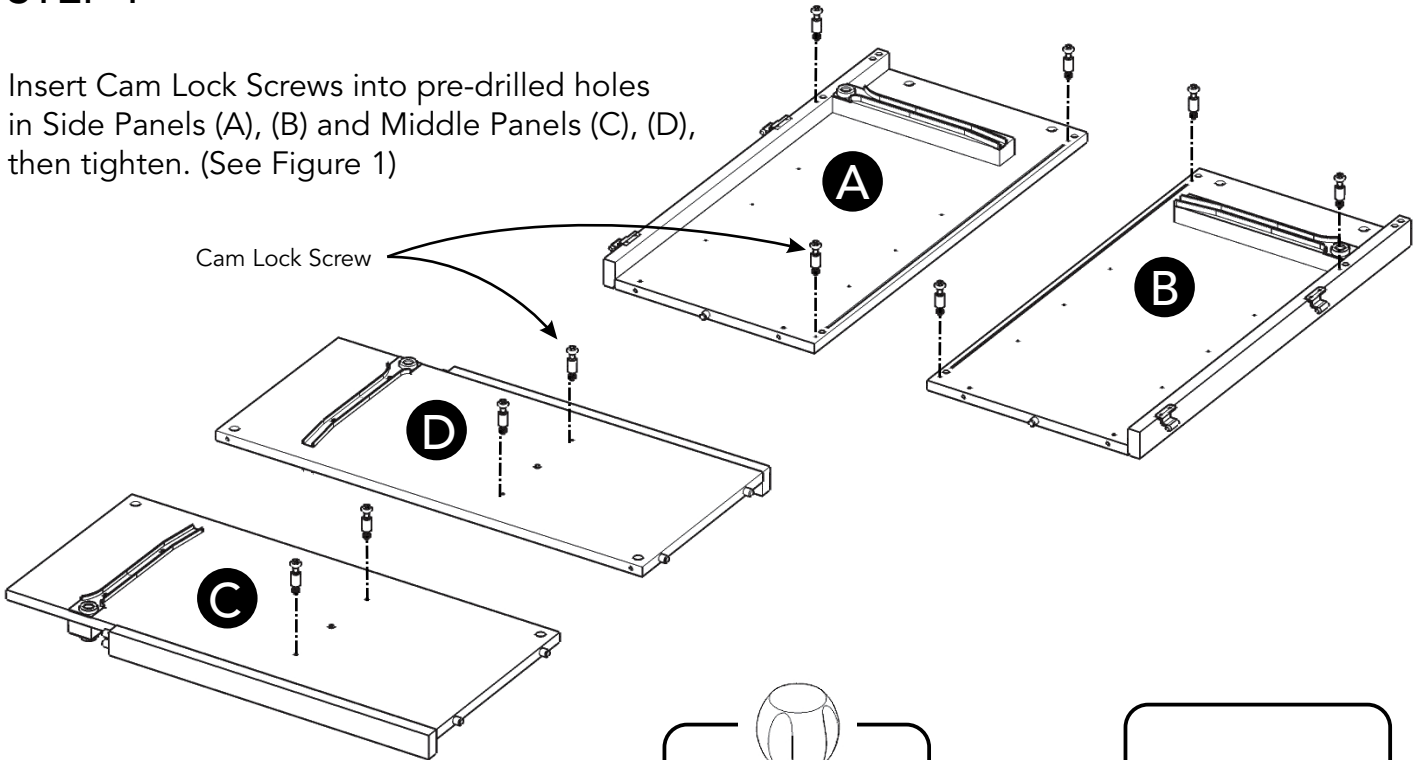

Figure 1

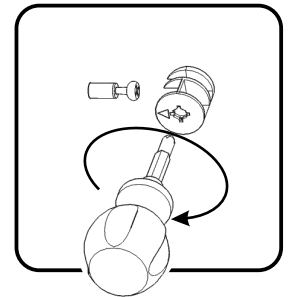
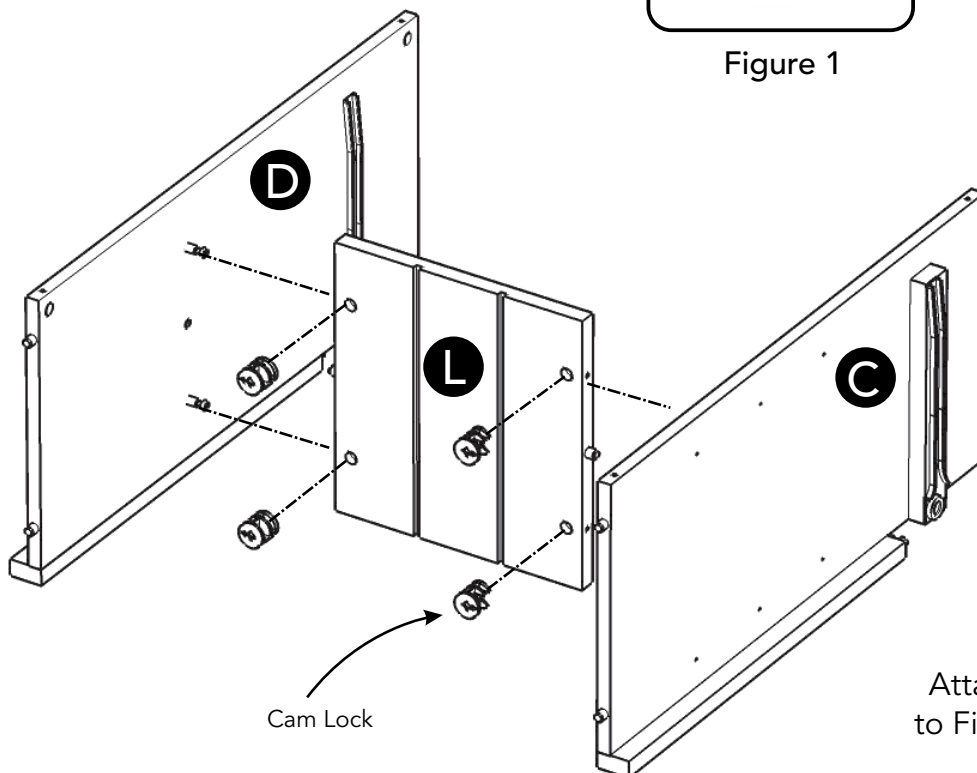

Figure 2



STEP 2

Attach Middle Panels (C) and (D) to Fixed Shelf (L) with Cam Locks. (See Figure 2)

STEP 3

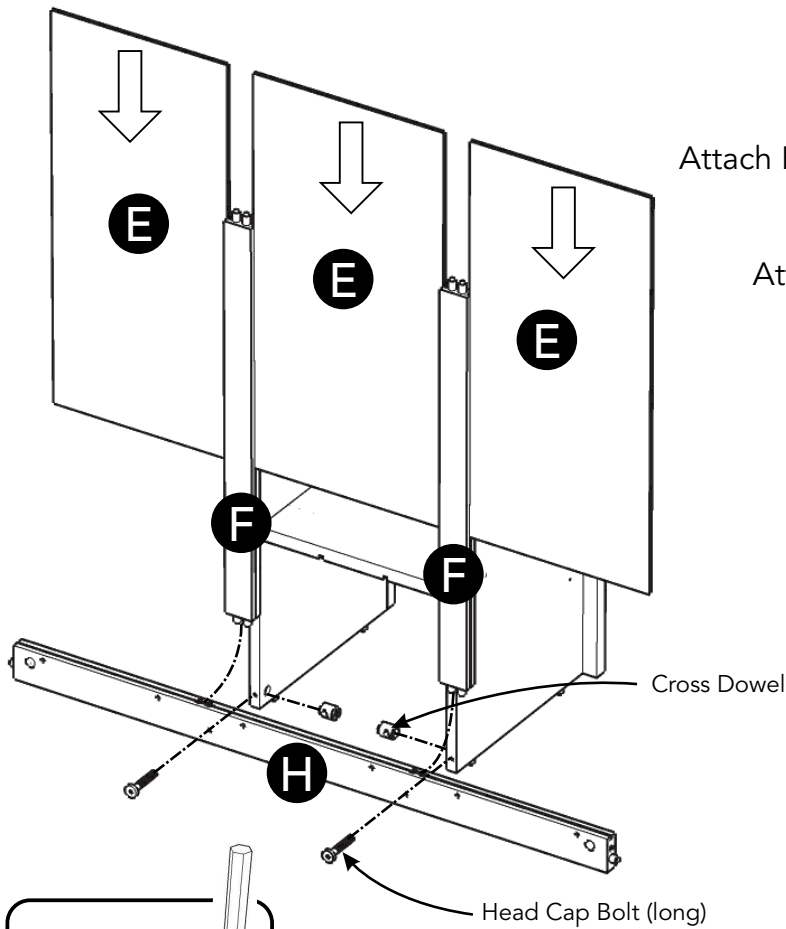

Attach Back Stretcher (H) to unit with Cross Dowels and Head Cap Bolts (long). (See Figure 3)

Attach Back Uprights (F) to Back Stretcher (H).

Slide Back Panels (E) into position.

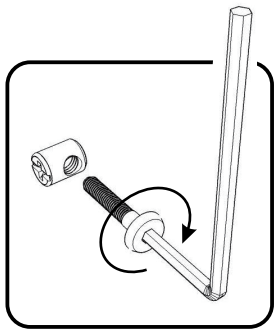
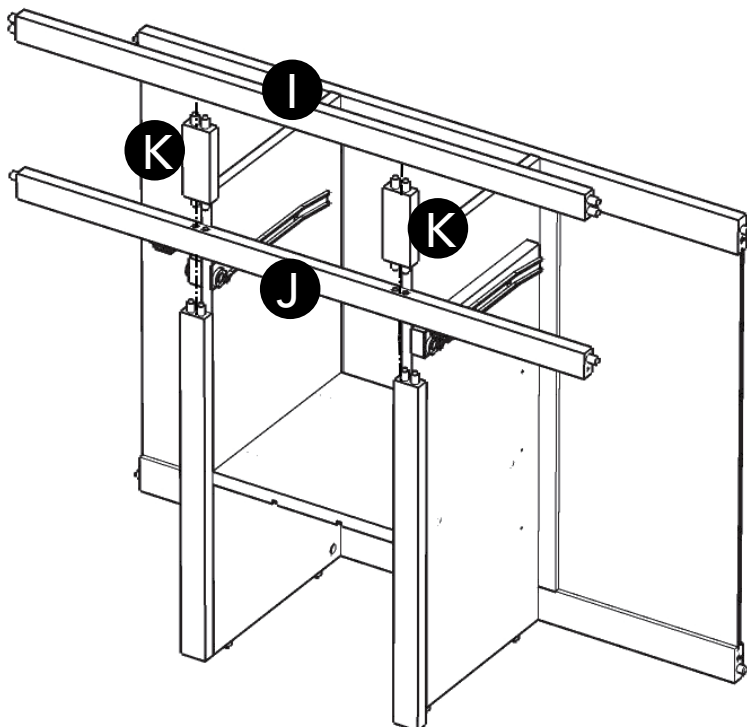
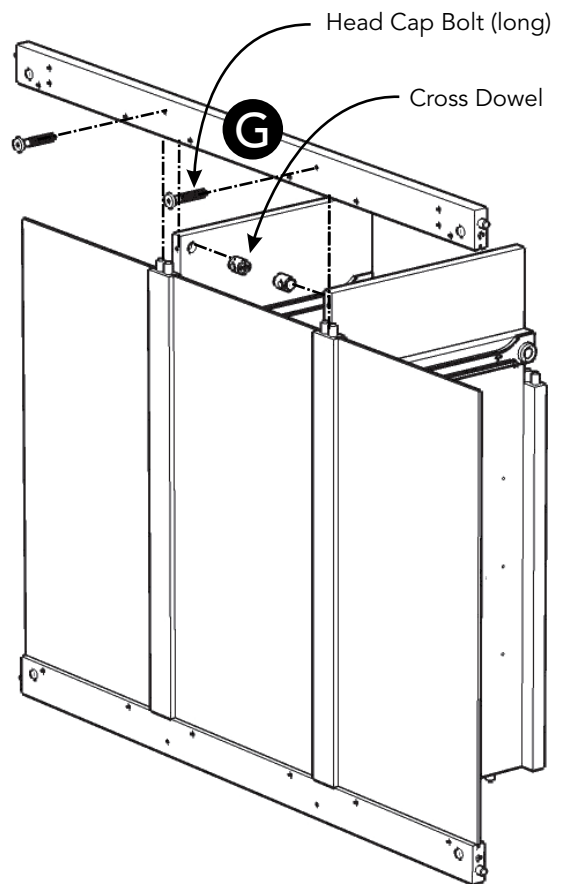

Figure 3

STEP 4

Attach Back Stretcher (G) to unit with Cross Dowels and Head Cap Bolts (long).



STEP 5

Attach Front Stretcher (J) to unit.

Attach Front Uprights (K) to unit.

Attach Front Stretcher (I) to unit.

Assembly Instructions 4/8

STEP 6

Attach Side Panels (A) and (B) to unit with Cam Locks.

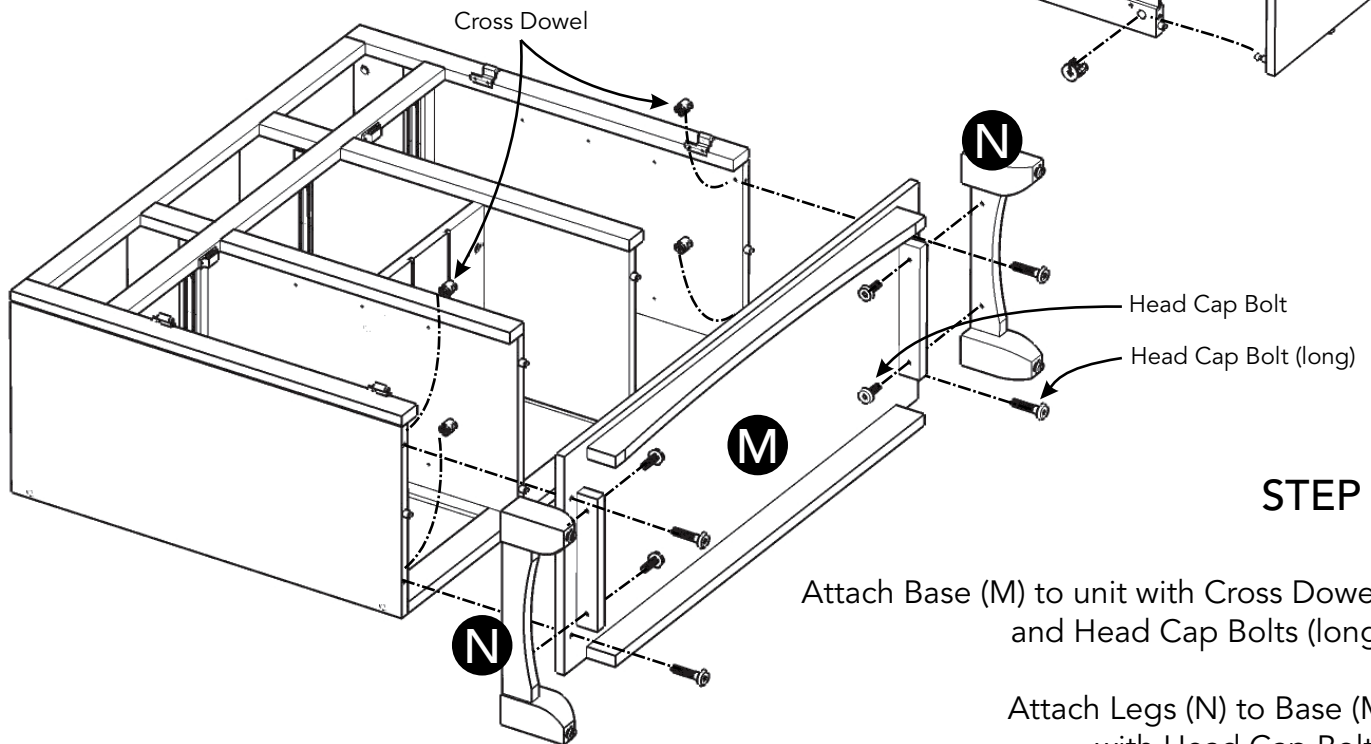
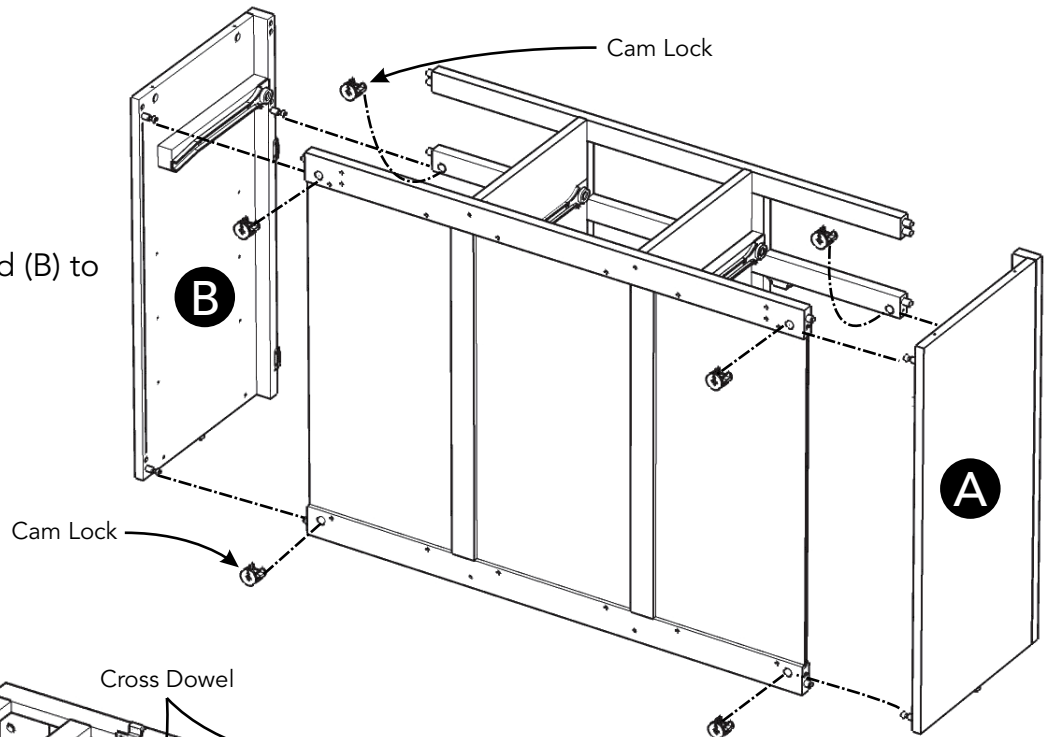

STEP 7

Attach Base (M) to unit with Cross Dowels and Head Cap Bolts (long).

Attach Legs (N) to Base (M) with Head Cap Bolts.

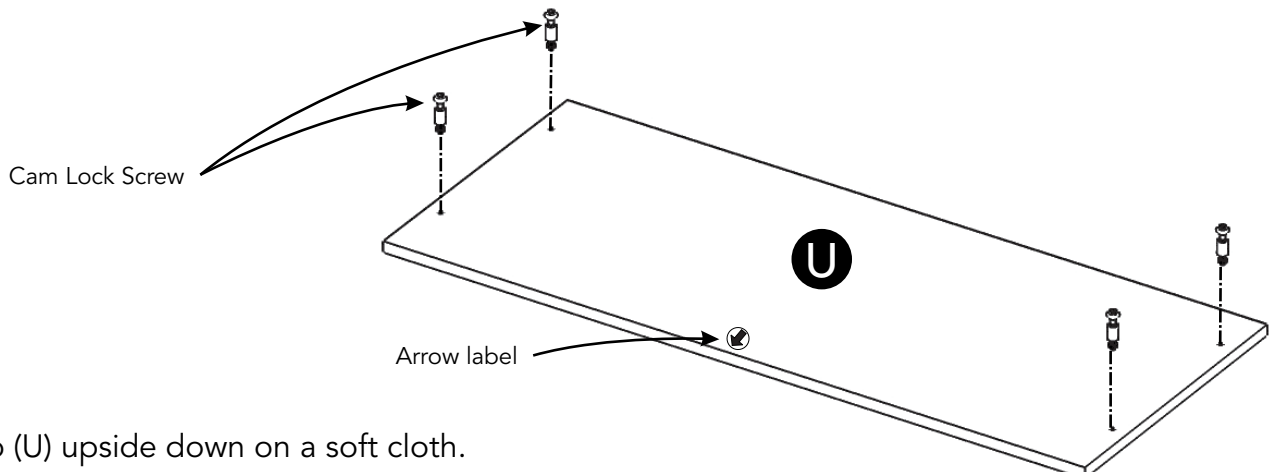

STEP 8

Place Top (U) upside down on a soft cloth.

Insert Cam Lock Screws into pre-drilled holes in Top (U), then tighten.

Assembly Instructions 5/8

STEP 9

Turn unit to its' upright position.

Insert Adjustable Pins into side panels and middle panels at desired level.

Place Shelves (Q) into position.

Attach Doors (R) and (S) to unit by sliding door hinges into side panel hinges. (See Figure 4)

Attach Knobs to Doors (R) and (S) with Machine Screws. (See Figure 5)

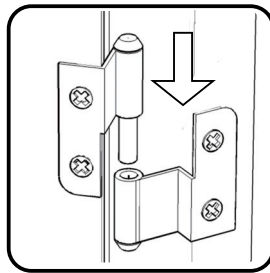
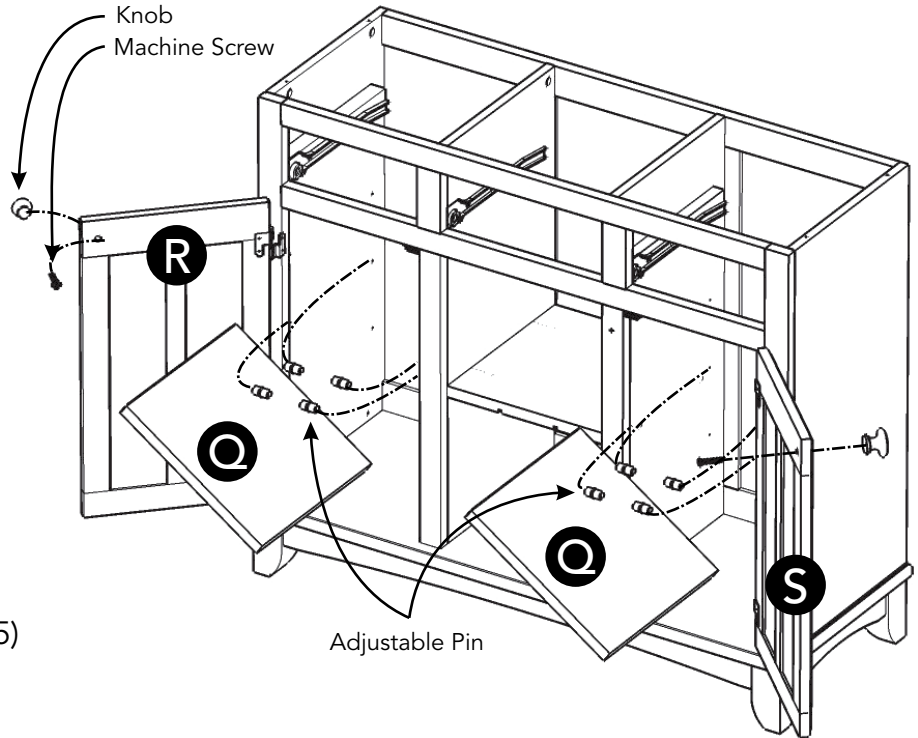

Figure 4

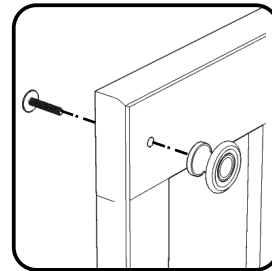
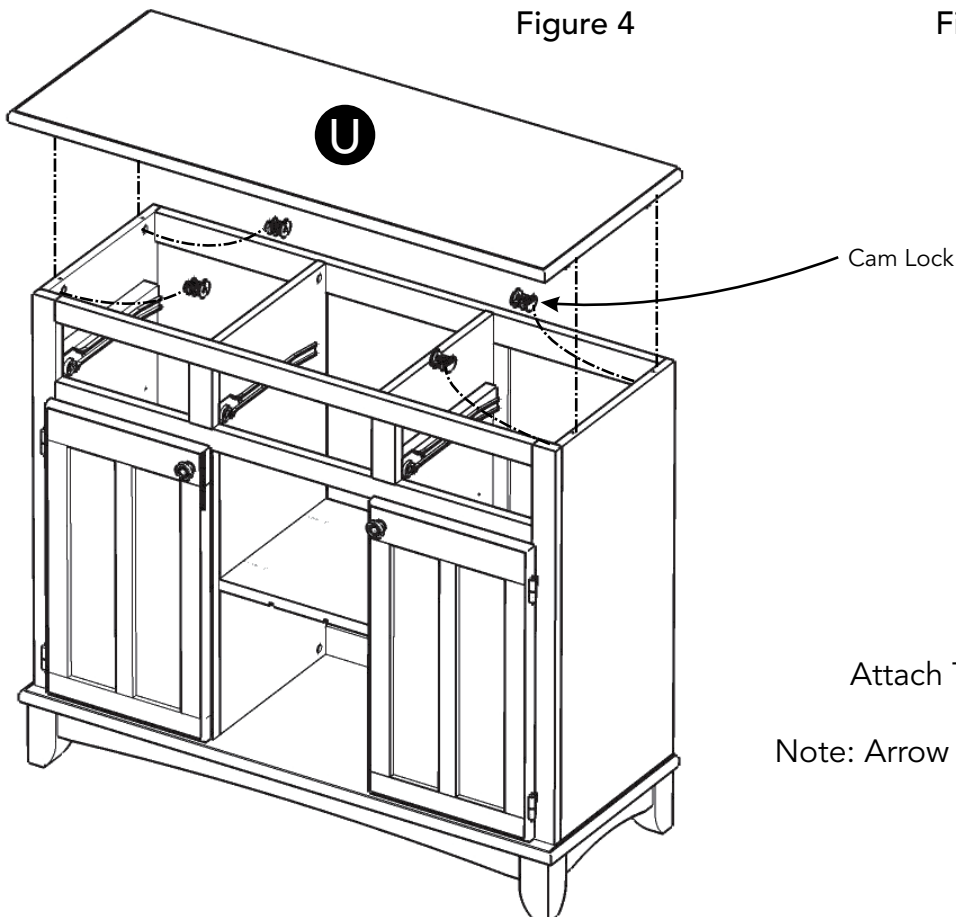

Figure 5



STEP 10

Attach Top (U) to unit with Cam Locks.

Note: Arrow label indicates front of Top (U).

Assembly Instructions 6/8

Drawer (T)

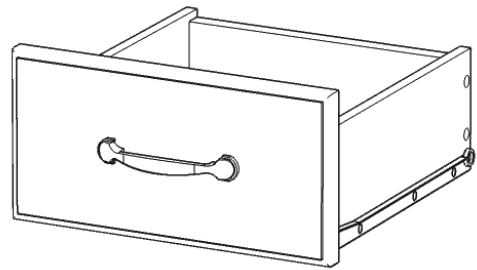
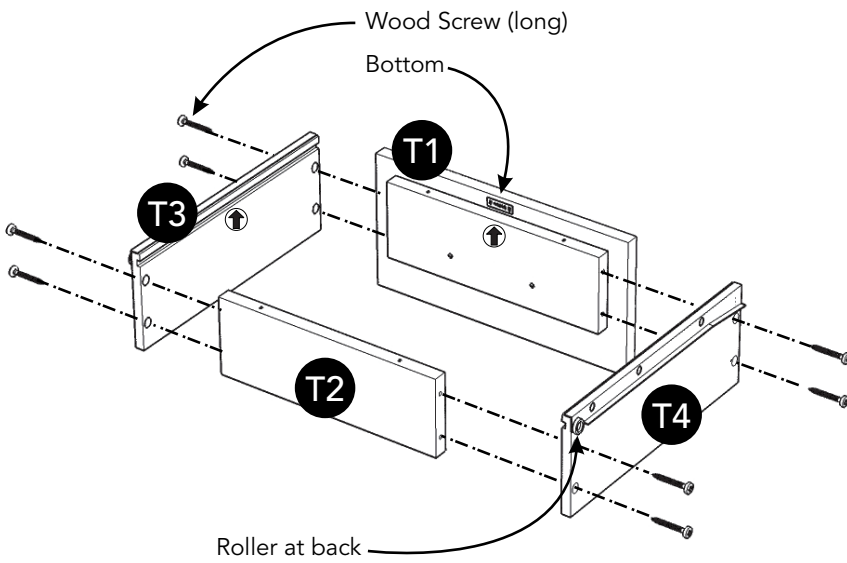

STEP 11

Attach Drawer Front (T1) and Drawer Back (T2) to Drawer Side (T3) with Wood Screws (long).

Attach Drawer Side (T4) to unit with Wood Screws (long).

STEP 12

Slide Drawer Bottom (T5) into groove.

Attach Drawer Bottom (T5) to unit with Wood Screws (short).

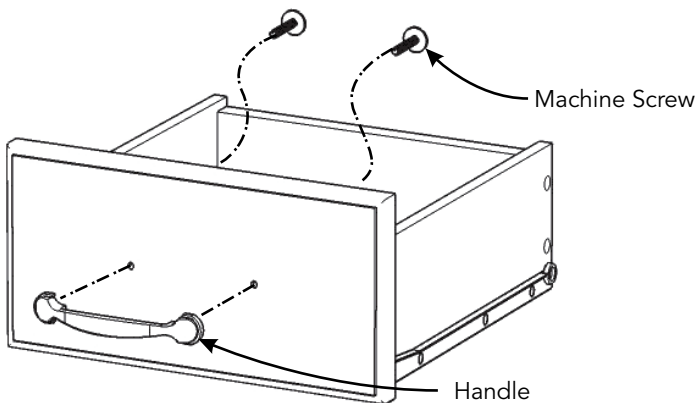
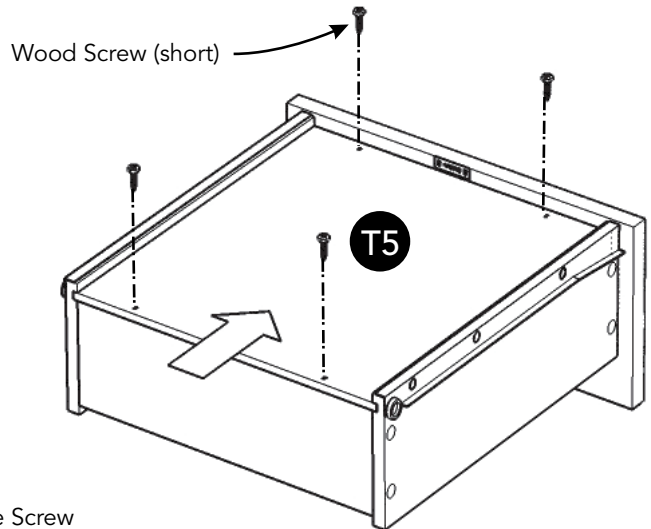

STEP 13

Attach Handle with Machine Screws.

Part List

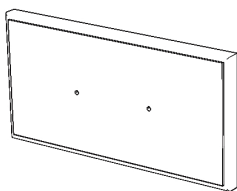

T1.
Drawer Front
3 pcs.

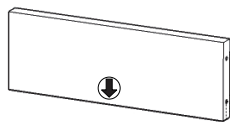

T2.
Drawer Back
3 pcs.

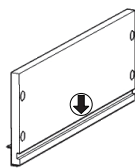

T3.
Drawer Side
3 pcs.

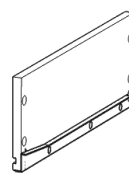

T4.
Drawer Side
3 pcs.

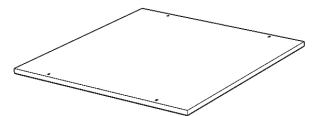

T5.
Drawer Bottom
3 pcs.

Assembly Instructions 7/8

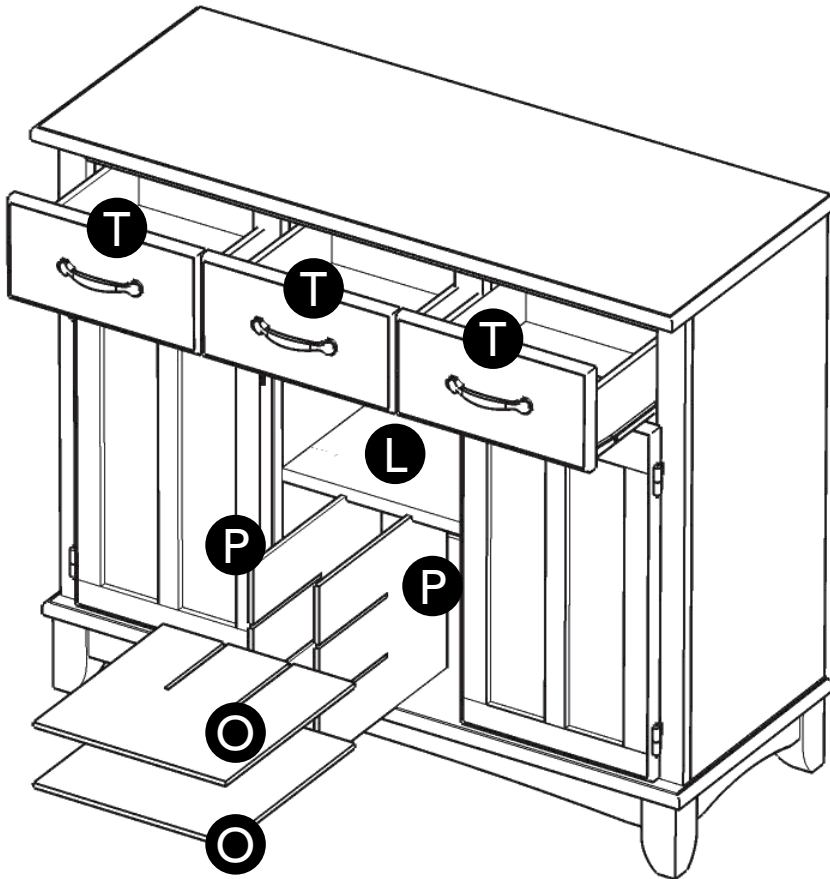

STEP 14

Slide Drawers (T) into position.

Slide Wine Grids (P) into grooves of Fixed Shelf (L).

Slide Wine Grids (O) into unit.

STEP 15

Level unit by adjusting the adjustable levelers on bottom of unit.
(See Figure 6)

Insert Wood Screws for Back Panel into pre-drilled holes in unit, then tighten.

Note: Unit must be level before tightening these screws.

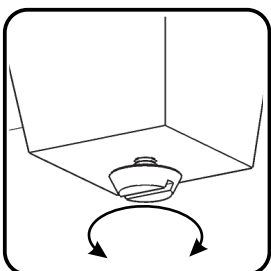
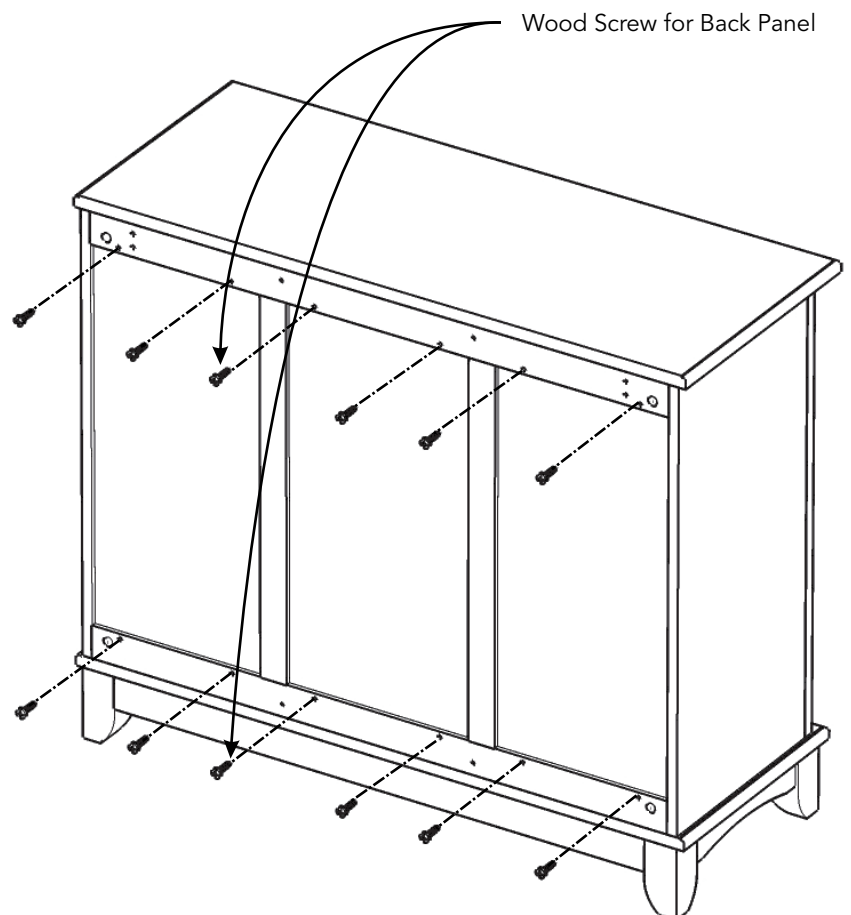

Figure 6



Wood Screw for Back Panel

Assembly Instructions 8/8

IMPORTANT

- To help reduce the risk of the unit tipping over, the Tip-over Restraint must be installed following these instructions exactly.

STEP 16

Place unit at desired location.

Drill a 3/8" hole in wall in-line with Pre-drilled hole at top of unit.

Move unit.

Insert Anchor into the wall hole and attach Bracket with Wall Screw.

Attach Bracket at pre-drilled hole at top of unit with Wood Screw.

Move unit back into place.

Slide Tip-over Restraint through Bracket on wall and Bracket on unit.
(See Figure 7)

Put tie end of Tip-over Restraint into lock end of Tip-over Restraint and pull until tight.

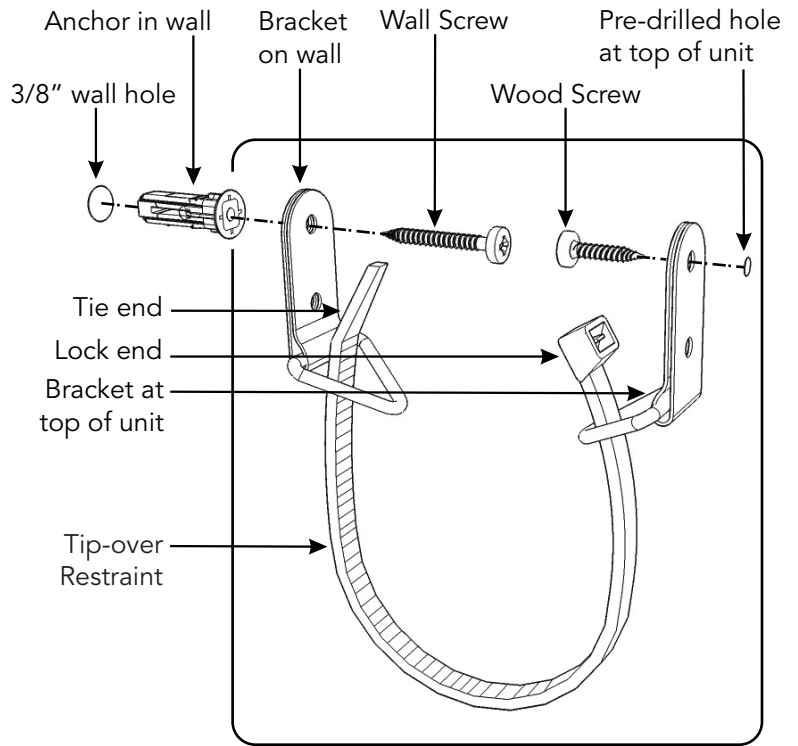
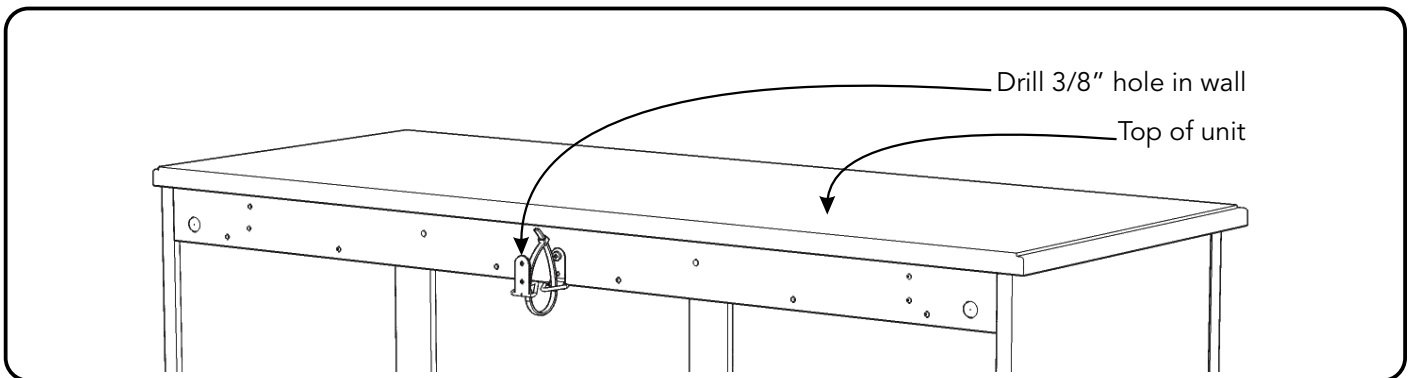
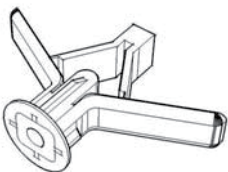

Figure 7



Hardware List



Anchor
1 pc. (+1 extra)

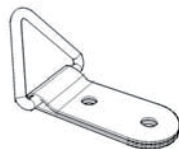

Bracket
2 pcs. (+1 extra)

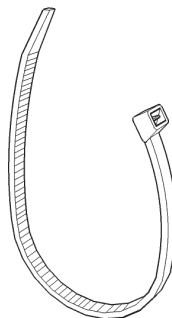

Tip-over Restraint
1 pc. (+1 extra)

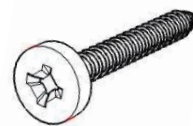

M3.5x40
Wall Screw
1 pc. (+1 extra)

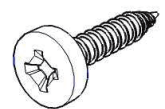

M3.5x16
Wood Screw
1 pc. (+1 extra)

CARE INSTRUCTIONS

NEVER

allow liquids to remain on furniture.
Absorption causes parts to warp
and split and finishes to delaminate.

NEVER

use glass cleaners on
finished furniture. Ammonia
chemically attacks the finish.



Do not use power tools
above 8 volts to assemble.
**PREVENT
CRACKING**



Do not place
in direct sunlight.
**PREVENT
FADING**



Do not write
directly on surface.
**PREVENT
MARKING**



Do not place hot
objects on surface.
**PREVENT
FINISH DAMAGE**

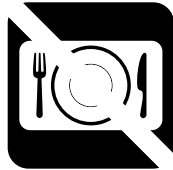

Do not use rubber
based placemats.
**PREVENT
DISCOLORING**



Do not use commercial
waxes and polishes.
**PREVENT
YELLOWING**

CLEAN

with a soft cloth moistened
in lukewarm soap and water.
Buff with a dry clean cloth.



Home Styles will provide replacements free of charge for missing or damaged hardware or parts within 30 days of purchase. Digital images of the defective parts may be required. If the product was not purchased from an authorized retail affiliate, Home Styles is under no obligation to provide replacement parts. Parts are not available for fully assembled items nor are parts available for sale. Replacements for missing or damaged hardware or parts may be requested at:

www.homestyles-furniture.com/customer-service/replacement-parts

Home Styles Customer Service: www.homestyles-furniture.com,
servicedesk@homestyles-furniture.com, 888-680-7460, 877-831-0319