

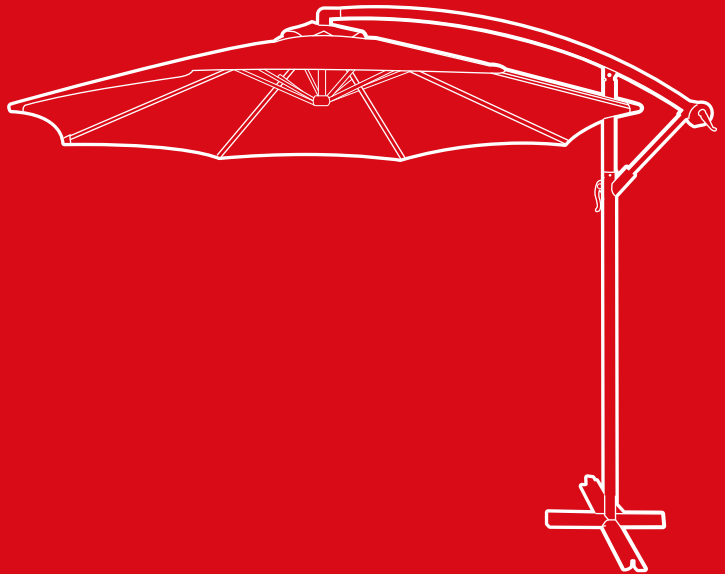

bestchoiceproducts



INSTRUCTION MANUAL

10-Foot Patio Offset Umbrella

Ver. 1

SKY5680 + SKY5681 + SKY5682 + SKY5683 + SKY5684
SKY5685 + SKY5686 + SKY5687 + SKY5688 + SKY5689



bestchoiceproducts

As shoppers, we're always trying to find the perfect balance between quality & value. At BCP, we believe we've achieved that. Our diverse catalog of everyday essentials is tailored especially to our customers & guaranteed to hit that sweet spot of high quality & low price.

— Always. —

! NOTICE

Please retain these instructions for future reference.

- Umbrella base weights are not included. Do not use this umbrella without umbrella base weights.
- Place umbrella on a stable and level surface.
- Umbrella is suitable for rain showers and light wind.
- Do not use umbrella in inclement weather, such as snow, heavy rain, thunderstorms, or strong wind.
- Firmly secure all bolts, screws and knobs before use.
- Reconfirm that all bolts, screws, and knobs are secure every 90 days.
- Fasten screws loosely during initial assembly. Do not firmly tighten the screws until the item is completely assembled.
- Be aware that some parts are heavy and have sharp edges.
- If any parts are missing, broken, damaged, or worn, stop using this product until repairs are made and/or factory replacement parts are installed.
- Do not use this item in a way inconsistent with the manufacturer's instructions as this could void the product warranty.

TOOLS REQUIRED



WRENCH
(PROVIDED)



1 PERSON
ASSEMBLY



APPROXIMATELY
15 MIN.
ASSEMBLY

HARDWARE

1

M8 x 16mm
SCREW

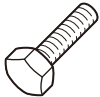

4 PCS

2

WASHER



4 PCS

3

KNOB



2 PCS

PARTS

A

CROSSBAR I

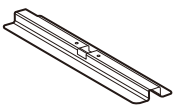

1 PC

B

CROSSBAR II

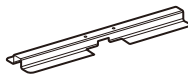

1 PC

C

BASE

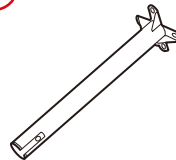

1 PC

D

UMBRELLA

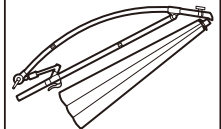

1 PC

BEFORE FIRST USE

1. Hold the umbrella upside down and shake gently to separate the umbrella ribs. If necessary, carefully pull the ribs apart to free them.
2. Slowly turn the crank to open the umbrella. Make sure that the ribs are not stuck together.

PRODUCT ASSEMBLY

1

Insert the part B crossbar into the part A crossbar.

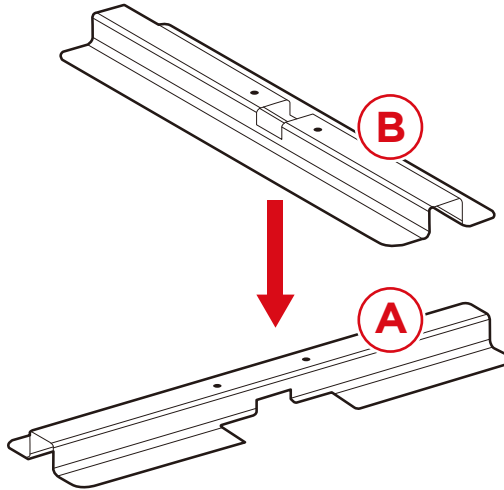

2

Attach the part C base to the crossbars with four part 1 screws and four part 2 washers. Partially screw in two part 3 knobs.

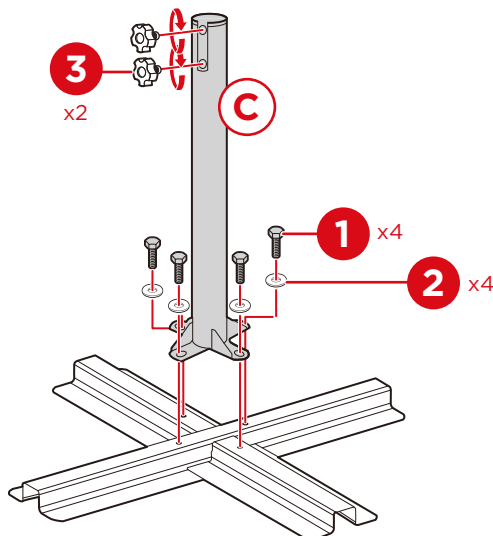

PRODUCT ASSEMBLY

3

Firmly insert the canopy of the part D umbrella into the umbrella frame.

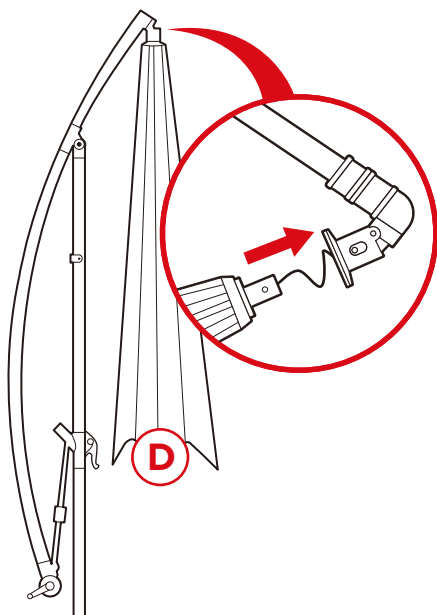

4

Insert the umbrella into the part C base. Tighten the two knobs to lock it in place.

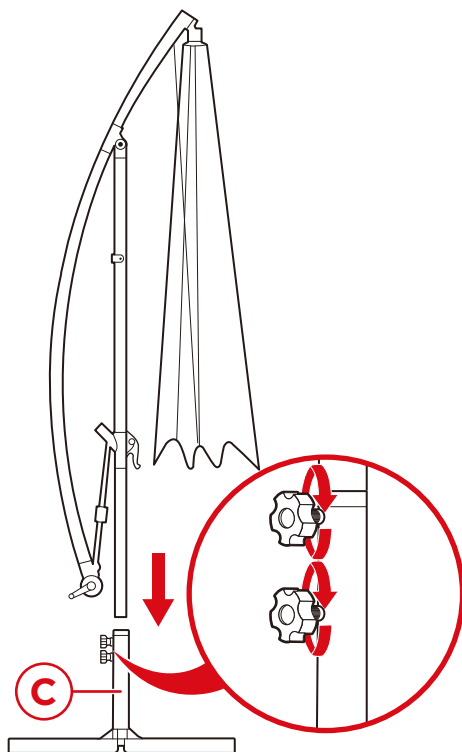

FEATURES

Opening Canopy

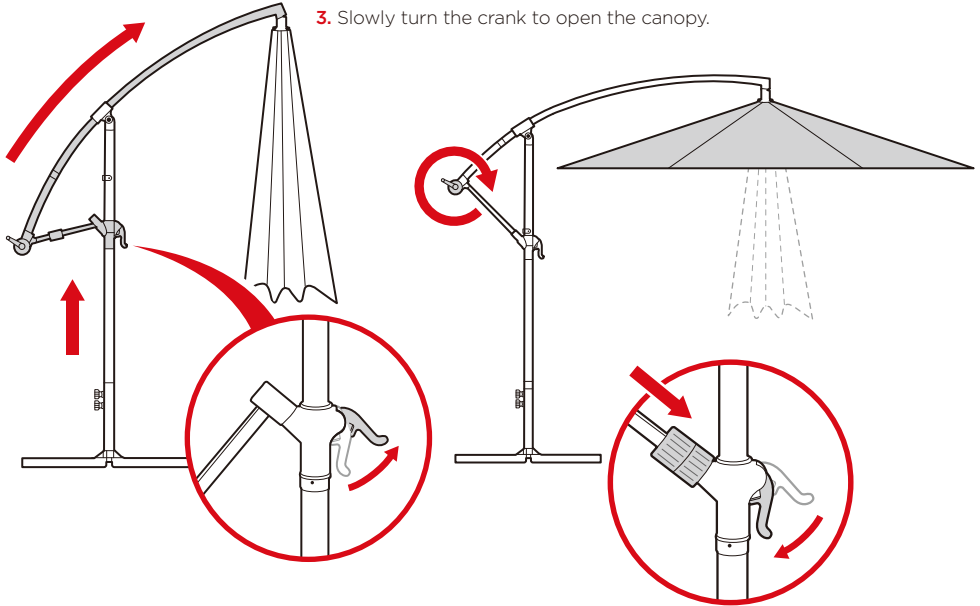

Adjusting Tilt

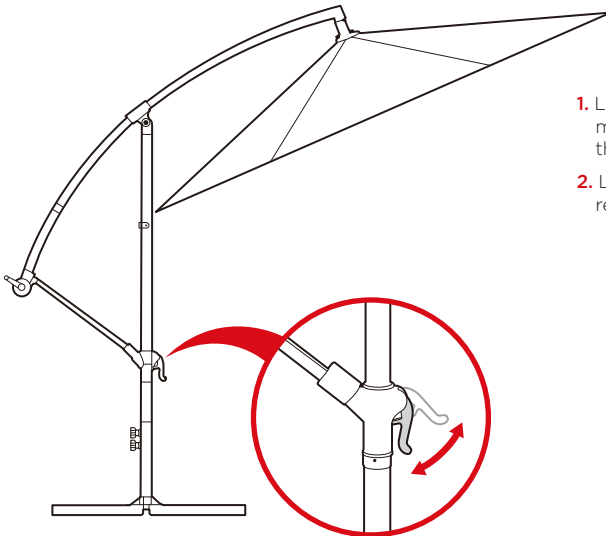

FEATURES

Closing Canopy

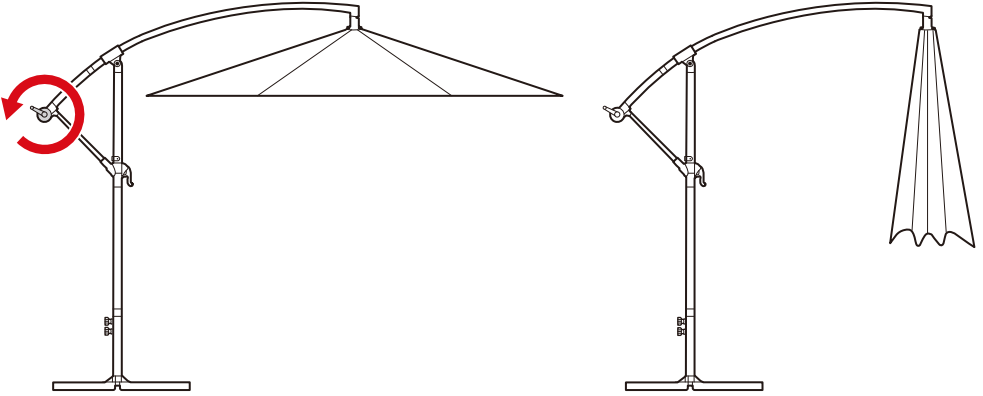

- Turn the crank counterclockwise to close the canopy.

Storage

- Close the canopy when umbrella is not in use.
- Flip the handle and move the arm all the way down to prepare the umbrella for storage.
- Store in a dry area shielded from the weather.
- If necessary, cover with a furniture cover or tarp.

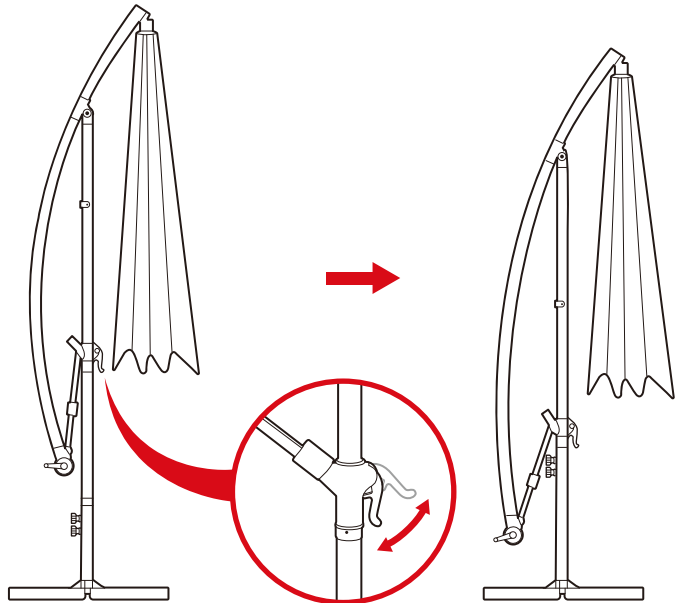

CLEANING

- Wipe clean with mild detergent, warm water, and a soft cloth.
- Do not use abrasive materials or cleaners.
- Store in a dry area shielded from the weather.
- If necessary, cover with a furniture cover or tarp.



HELP CENTER



Question about your product? We're here to help. Visit us at:

help.bestchoiceproducts.com



Chat Support



Product Inquiry



Orders FAQ



Product Assembly



Returns & Refunds

PRODUCT WARRANTY INFORMATION

All items can be returned for any reason within 60 days of the receipt and will receive a full refund as long as the item is returned in its original product packaging and all accessories from its original shipment are included. All returned items will receive a full refund back to the original payment method. All returned items will not be charged a re-stocking fee.

All returned items require an RA (Return Authorization) number, which can only be provided by a Best Choice Products Customer Service Representative when the return request is submitted. Items received without an RA may not be accepted or may increase your return processing time. Once an item has been received by Best Choice Products, refunds or replacements will be processed within 5 business days.

All returns must be shipped back to the Best Choice Products Return Center at the customer's expense. If the reason for return is a result of an error by Best Choice Products then Best Choice Products will provide a pre-paid shipping label via email. Boxes for return shipping will not be provided by Best Choice Products, and is the customer's responsibility to either use the original shipping boxes or purchase new boxes.

Pictures may be required for some returns to ensure an item is not damaged prior to its return. Items returned are not considered undamaged until they are received by Best Choice Products and verified as such. All damages to items are the customer's responsibility until the item has been received by and acknowledge by Best Choice Products as undamaged.



WARNING

Manufacturer and seller expressly disclaim any and all liability for personal injury, property damage or loss, whether direct, indirect, or incidental, resulting from the incorrect attachment, improper use, inadequate maintenance, or neglect of this product.