





HEKMAN®

A HOWARD MILLER COMPANY

ASSEMBLY INSTRUCTIONS FOR 23103 LAMP TABLE

HARDWARE LIST

NO.	ITEM	DESCRIPTION	QTY
1		JCB Bolt M6x40 MM.	8
2		JCB Bolt M6x15 MM.	4
3		Lock Washer M6	8
4		Allen wrench	1

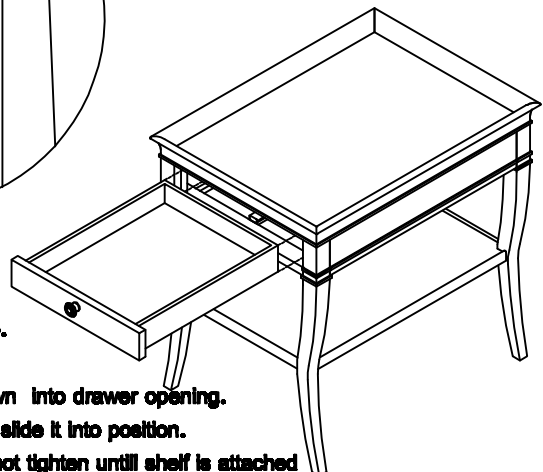
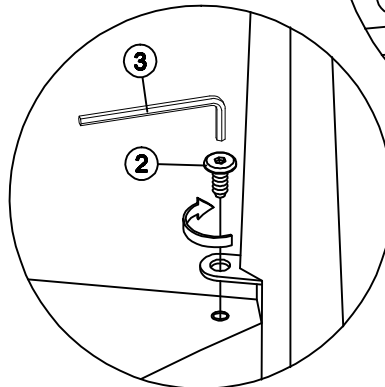
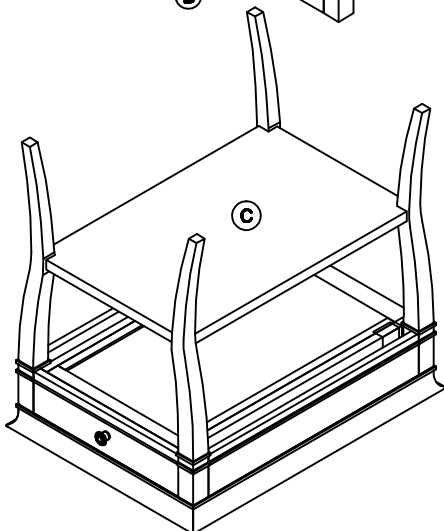
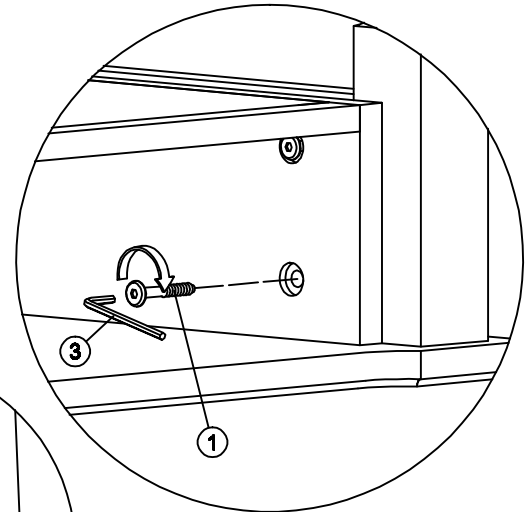
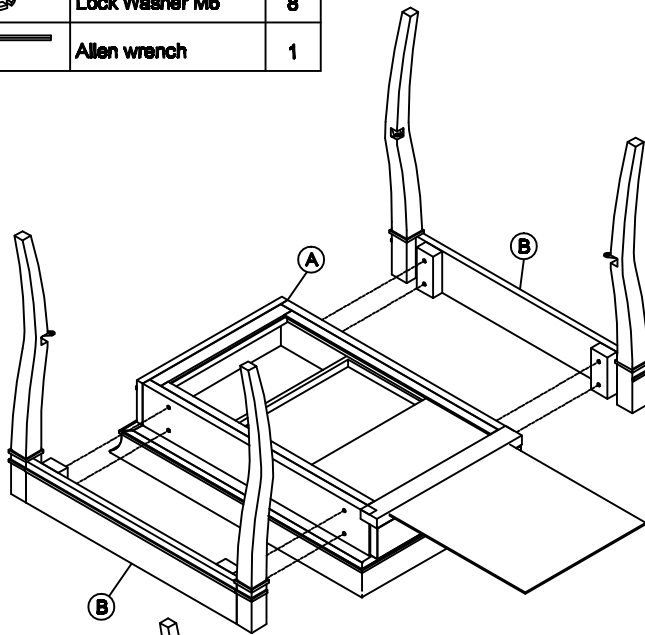
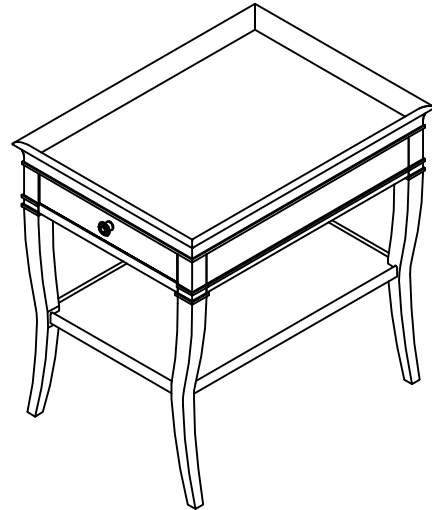

TO ASSEMBLE :

Step 1 : Remove drawer . Last few inches will pull hard to get past drawer stop.

Step 2 : Turn case on its top on soft clean surface.

Step 3 : Remove dust panels : slide dust panels to back of case then push down into drawer opening.

Step 4 : Align holes in end panel (B) with holes on side of drawer box (A) and slide it into position.

Step 5 : Using four JCB bolt (1) attach each panel (B) to drawer box (A). Do not tighten until shelf is attached

Step 6 : Attach the shelf (C) to legs (B) in the notch, tighten using JCB bolt M6x15 (2) with allen wrench (3).

Tighten the JCB Bolt (1) in Step 3 fully with allen wrench (3).

Step 7 : Install Dust Panel through drawer opening.Slide Dust panel into slot in backrail then Forward into slot in Front rail.

Step 8 : Turn case up right and install drawer.