

BLACK DIAMOND®

Project Name: _____

Location: _____

Item #: _____

Qty: _____

Black Diamond Gas Deep Fryer, Natural Gas, 70 lb, 150K BTU, in Stainless Steel

BDGF-150/NG



Enhance your commercial kitchen with this high-performance Black Diamond Gas Deep Fryer, perfect for preparing french fries, chicken wings, and more. Made from durable stainless steel and cast iron, it promises longevity and efficient operation. With a 70-pound capacity, it caters to high-volume demands. The fryer operates between 200° to 400°F, powered by 150,000 BTUs for consistent performance. Manual ignition and control ensure ease of use, while cleaning is simplified with its removable components.

FEATURES AND CONSTRUCTION

- Constructed with durable stainless steel and cast iron
- Delivers a powerful 150,000 BTUs for efficient frying
- Equipped with 5 burners for versatile cooking options
- Offers a 70 lb capacity for high-volume frying needs
- Equipped with casters for mobility
- Includes standard coupling adaptor and natural gas connection
- Features manual ignition and control for precision cooking
- Temperature range of 200° to 400°F for versatile cooking
- Designed for high-volume commercial kitchen environments
- Perfect for frying a variety of foods like french fries and chicken wings

FRYER ACCESSORIES (OPTIONAL)

- Stainless Steel Cover
- Joiner Strips
- Splash Guard
- Fryer baskets available in a variety of sizes

3RD PARTY APPROVALS



WARRANTY (USA / CANADA)

One (1) Year Limited Warranty on Parts and Labor, Five (5) Year Warranty on Stainless Steel Fry Tank

Contact us for details at 1.877.368.2797



INCLUDED COMPONENTS

- (4) Casters
- (2) Baskets
- (1) Basket Support Rack
- (1) Basket Hanging Plate
- (1) Oil Drainage Extension Pipe

TEMPERATURE

Overall Temperature (Fahrenheit):

- Minimum: 200° - Maximum: 400°F



Black Diamond Gas Deep Fryer, NG, 70 lb, 150K BTU

BDGF-150/NG

FRONT

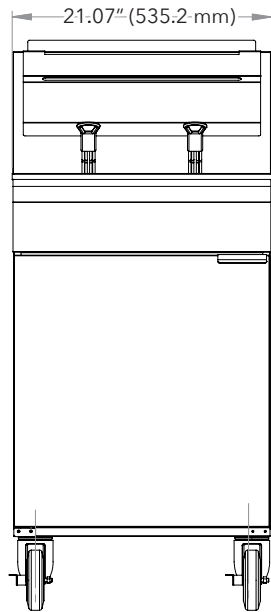

SIDE

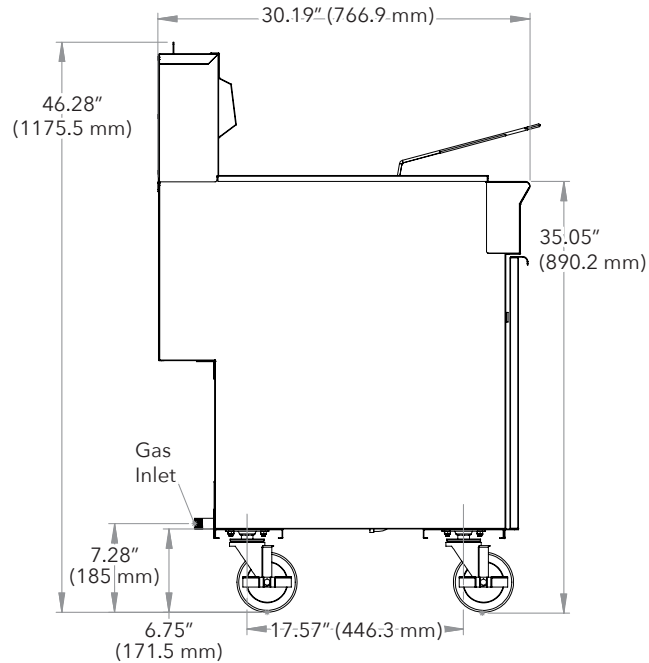

TOP

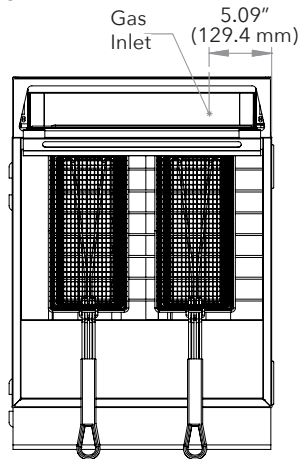

Gas

Capacity (lbs. of oil)	Temperature Range (Fahrenheit)	BTU / Hour	Assembled Dimensions (in)	Item Weight (lbs)	Shipping Weight (lbs)
70 lbs	200° - 400°	150000	30.19" x 21.07" x 46.28"	165.4	205.1

ADDITIONAL INFORMATION

- Electricity not needed.
- Liquid Propane (LP) or Natural Gas (NG) units available. Field convertible from LP to NG and vice versa.
- Minimum supply pressure is 4" W.C. for natural gas and 10" W.C. for propane.
- Gas powered appliances must always be indoors, under an approved exhaust system with grease removal filters and a fire protection system.

Due to periodic changes in designs, methods, procedures, policies and regulations, the specifications contained in this document are subject to change without notice. While we exercise good faith efforts to provide information that is accurate, we are not responsible for errors or omissions in information provided or conclusions reached as a result of using the specifications. By using the information provided, the user assumes all risks in connection with such use.