



## KoldLok® Surface Mount Grommets

### Part Numbers

Original - 2020

Large - 2030

XLarge - 2040



Original - Part No. 2020



Large - Part No. 2030



XLarge - Part No. 2040

### Applications

Designed to seal a variety of existing raised floor tile cut-outs without capturing cables in edge cutouts. Item Nos. 2030 and 2040 allow for larger sealing capacities. Based on measurements at multiple data centers, on average 60% of valuable conditioned air is not reaching the air intake of IT equipment due to unsealed floor openings. This lost air, known as bypass airflow, contributes to IT equipment hot spots, cooling unit inefficiencies, and increasing infrastructure costs. KoldLok products specifically address bypass airflow and its detrimental effects on data center cooling.

### Features

- The Surface Mount Grommets facilitate re-cabling and allows tile to be moved without capturing cables
- The Grommets contain no loose or partially fastened parts, which can become separated or fall through the raised floor
- The Grommets are impact resistant and durable
- KoldLok products are compliant with Directive 2015/863/EC of the European Parliament and the Council on the Restriction of the Use of Certain Hazardous Substances in Electrical and Electronic Equipment (RoHS 3)
- KoldLok products are also REACH compliant

### Benefits

- Increases the utilization of existing cooling unit capacity
- Reduces the need to purchase additional cooling units
- Improves equipment reliability and extends equipment life
- Increases static pressure under the raised floor and improves cool air delivery through perforated tiles and floor grates
- Facilitates Cold Aisle/Hot Aisle best practices

### Sealing Effectiveness

- Effective bypass-airflow sealing in areas undisturbed by cable penetrations at static pressures up to 0.10 inches of water column
- Best in class bypass-airflow sealing with four, half-inch cables penetrating the Grommet at a static pressure of 0.10 inches of water column

# Specifications

Dimensions and Tile Cutting Requirements	Inches (W x D x H)	Millimeters (W x D x H)
<b>Part No. 2020 Original - Overall size</b>	11" x 8 1/4" x 1 1/8"	279 x 210 x 29mm
Product height above the raised floor	1 1/4" with mounting system installed	32mm
Maximum cutout size sealed	10" x 7 1/4"	254 x 184mm
Usable cable are	8 1/4" x 4 3/4" (39 sq in)	210 x 121 (25410 sq mm)
<b>Part No. 2030 Large - Overall size</b>	12" x 11 3/4" x 1 5/16"	305 x 298 x 33mm
Product height above the raised floor	1 7/16" with mounting system installed	37mm
Maximum cutout size sealed	10" x 9 3/4"	254 x 248mm
Usable cable are	8 1/4" x 4" (39 sq in)	210 x 121 (25410 sq mm)
<b>Part No. 2040 Extra Large - Overall size</b>	12" x 15" x 1 5/16"	305 x 381 x 33mm
Product height above the raised floor	1 7/16" with mounting system installed	37mm
Maximum cutout size sealed	10" x 13"	254 x 330mm
Usable cable are	8 1/4" x 4 3/4" (39 sq in)	210 x 121 (25410 sq mm)

## Patented Sealing System

(U.S. Patent No. RE41863 and International Patents Pending) Multi-layer, opposing and interwoven filaments consisting of:

- 0.010 inch diameter upper filaments
- 0.020 inch diameter lower filaments
- Approximately 25,000 filaments per Grommet
- Ensure passage of 100 amp power connectors

## Floor Mounting System

Custom adhesive mounting kit consisting of:

- Single-sided, pressure sensitive foam with adhesive backing
- Double-sided, pressure sensitive foam with adhesive backing
- All foam components are non-particulating

## Grommet Frame

The frame is molded from durable polypropylene. The frame consists of two, interlocking halves.

Finish: Black

2020 - KoldLok Surface Mount Original Raised Floor Grommet

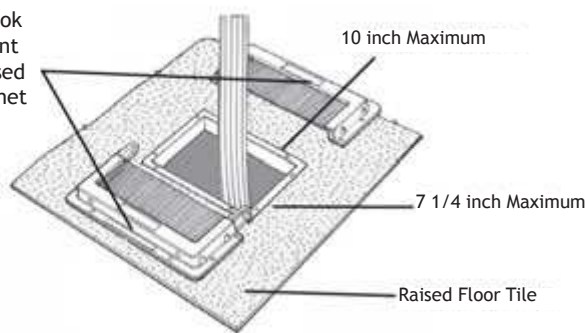

2040 - KoldLok Surface Mount Extra Large Raised Floor Grommet

