

## Features

Gauge: 90 mil.  
 Nominal capacity: 6.5 USG / 24.6 L  
 Stack performance: 350lbs.\*  
 Tare weights: Body: 2.54 lbs. / 1.15 kgs.  
 Tare weights: Cover: .66 lbs. / .30 kgs.  
 Note: \* Ratings will be reduced with uneven load distribution.

## Specifications with Cover

Dimensions: 12-5/16" DIA. X 18 7/8" H  
 Maximum capacity: 6.78 USG / 25.67 L  
 Tare weight: 3.20 lbs. / 1.45 kgs.

## Colors

Standard: White, Black, Natural  
 Custom: Available at manufacturer's discretion

## Decorating Options\*

Note: \*See Decoration Summary for further details.

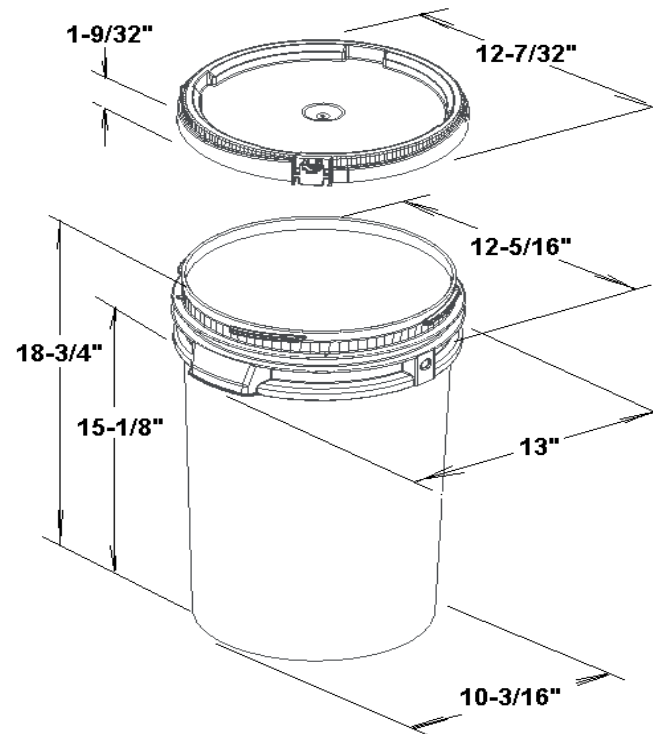

## Shipping Data

Qty. per pallet:  
 Gross Weight (lbs./kgs.):\*  
 Den. (lbs./C.F./kgs./m3):  
 Length (in./cm.):  
 Width (in./cm.):  
 Height (in./cm.):

## Bodies

108  
 274.32/124.2  
 5.3/84.58  
 49.88/126.7  
 37.56/95.6  
 47.75/121.3

## Covers

480  
 317.5/144  
 6.44/103.15  
 49/124.46  
 36.75/93.35  
 47.31/120.2

## Filled Containers

36 (12 per layer / 3 layers high)  
 Pallet height: 60.52"

## Materials

FDA and HPB approved materials Resin:  
 Body: High Density Polyethylene (HDPE)  
 Cover: High Density Polyethylene (HDPE)  
 MSDS Sheets available upon request

### DISCLAIMER

THIS INFORMATION IS PROVIDED AS A GENERAL GUIDE, INCLUDING DIMENSIONS. IT IS THE CUSTOMER'S RESPONSIBILITIES TO SELECT THE PROPER CONTAINER FOR PRODUCT AND APPLICATION COMPATIBILITY.

DISTRIBUTED BY:



REF NO.:

DWG30262

DESCRIPTION:

6.5 Gallon HDPE Screw Top Pail