

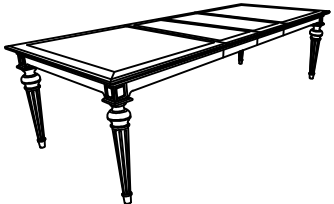





HEKMAN®

X A HOWARD MILLER COMPANY

23320 RECT. DINING TABLE Hardware List

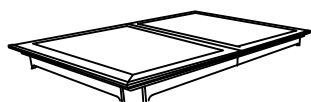
A	B	C	D	
ALLEN BOLT M8 X 70 (8 PCS.)	FLAT W. M8 8 PCS.	SPRING W. M8 8 PCS.	ALLEN KEY L5 (FOR ALLEN BOLT) 1 PC.	
				

PART INSIDE		
1	2	3
TOP ASSEMBLY (1 Pc)	LEAF ASSEMBLY (2 Pc)	LEG (4 Pcs)
		

Assembly Instruction

STEP 1.

LAY TOP PANEL UPSIDE DOWN ON A SOFT, CLEAN AND FLAT SURFACE. ALIGN BOLTS ON THE LEGS TO HOLES ON TOP PANEL AND CONNECT USING FLAT WASHER (B), SPRING WASHER (C), ALLEN BOLT (A) AND ALLEN KEY (D) PROVIDED.

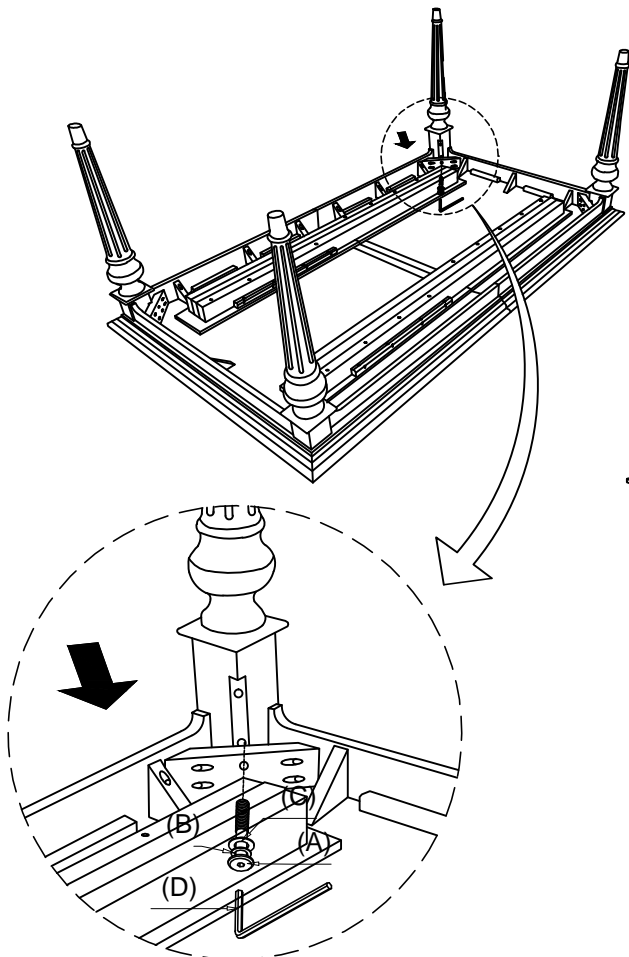

STEP 2:

TURN ASSEMBLED TABLE UPRIGHT.

* TO ATTACH EXTENSION LEAF, UNLOCK TABLE LOCKS UNDER THE TOP, SLIDE TABLE TOP HALVES APART AND PLACE EXTENSION LEAF TO THE OPENING AT RIGHT POSITION. SLIDE TOP HALVES TO HOLD EXTENSION LEAF IN PLACE LOCK THE TABLE LOCKS.

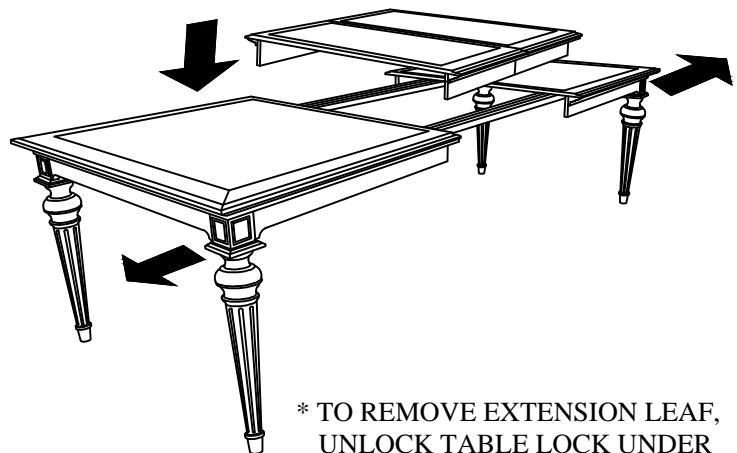

* TO REMOVE EXTENSION LEAF, UNLOCK TABLE LOCK UNDER THE TOP, SLIDE TABLE TOP HALVES APART. REMOVE EXTENSION LEAF (G) AND SLIDE TOP HALVES TOGETHER. LOCK THE TABLE LOCKS.