





# HEKMAN®

A HOWARD MILLER COMPANY

## 23807 CHAIR SIDE TABLE

### Hardware List

A	B	C	D	
ALLEN BOLT M6 X 20 (8 PCS.)	FLAT W. M6 8 PCS.	SPRING W. M6 8 PCS.	ALLEN KEY L4 (FOR ALLEN BOLT) 1 PC.	
				

### Assembly Instruction

#### STEP 1.

LAY TOP ASSEMBLY UPSIDE DOWN ON A SOFT, CLEAN AND FLAT SURFACE. ALIGN LEGS TO HOLES ON CORNER AND CONNECT USING PLAIN WASHER (B), SPRING WASHER (C), ALLEN BOLT (A) AND ALLEN KEY (D) PROVIDED.

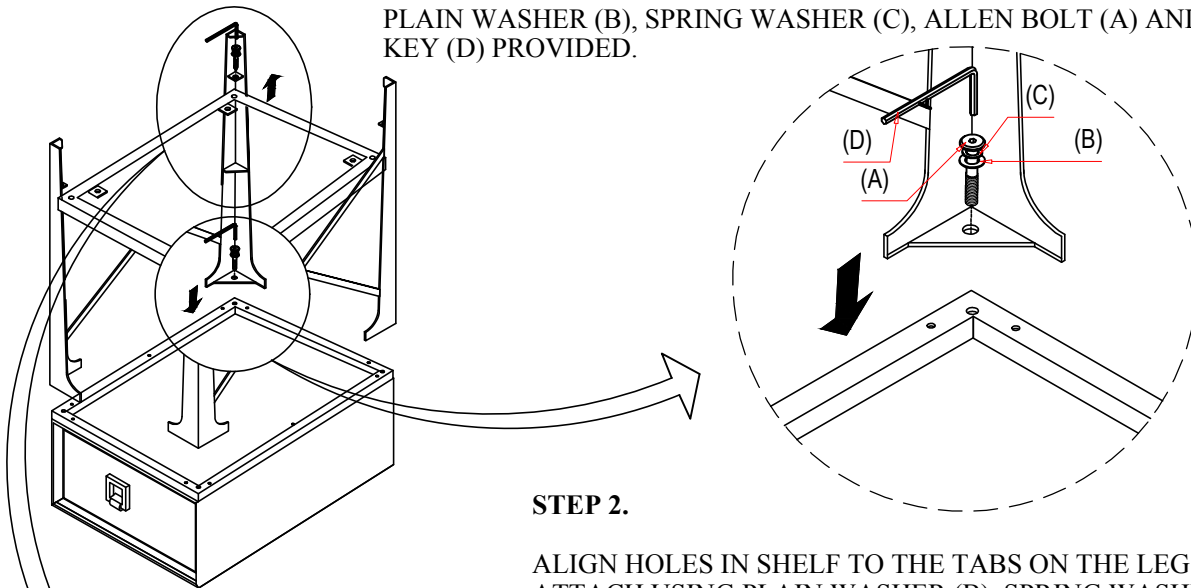

#### STEP 2.

ALIGN HOLES IN SHELF TO THE TABS ON THE LEGS. ATTACH USING PLAIN WASHER (B), SPRING WASHER (C), ALLEN BOLT (A) AND ALLEN KEY (E) PROVIDED. TIGHTEN ALL.

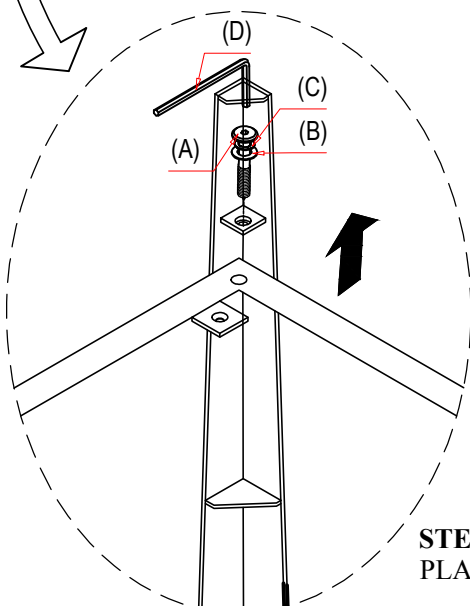

**STEP 3**  
TURN TABLE UPRIGHT.

**STEP 4**  
PLACE THE GLASS ON SHELF MIDDLE LEGS.

