







HEKMAN®

A HOWARD MILLER COMPANY

ASSEMBLY INSTRUCTION FOR 24903 END TABLE

HARDWARE LIST

NO.	ITEM	DESCRIPTIN	QTY.
1		JCB Bolt M6 X 20 MM	16
2		Flat washer M8X25 MM	16
3		Allen wrench	1
4		Bolt M8X20 MM	4
5		Wrench	1
6		Flat washer M6X18 MM	4

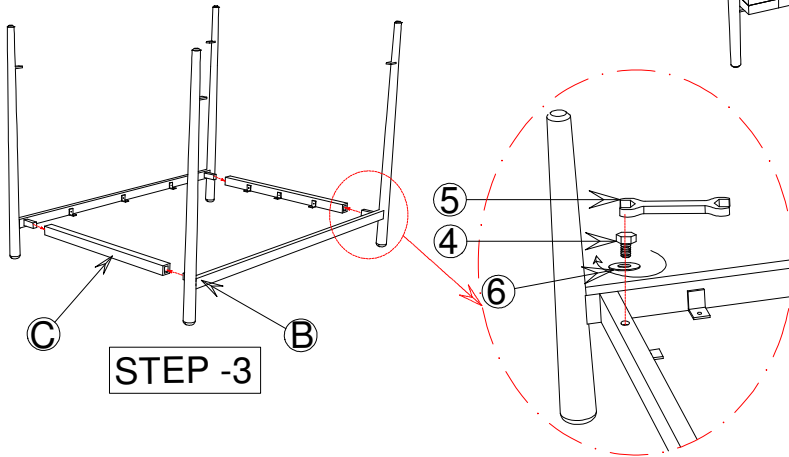
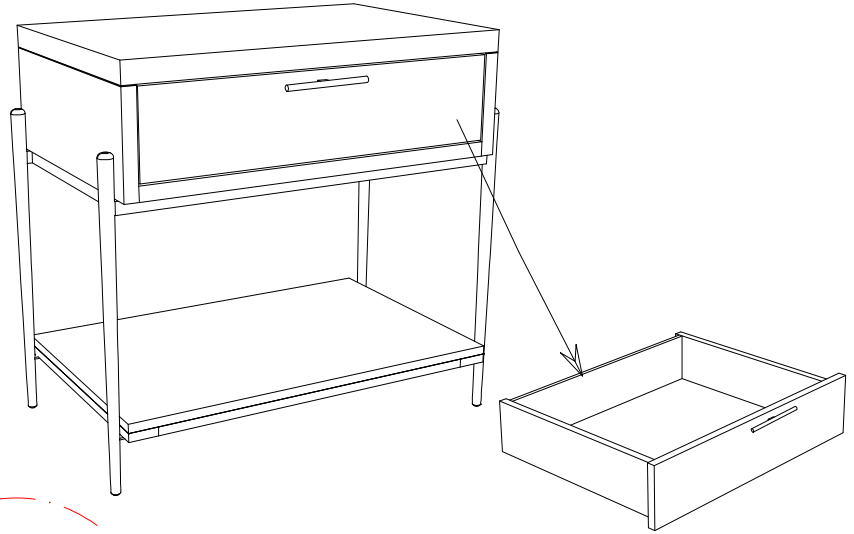

STEP -3

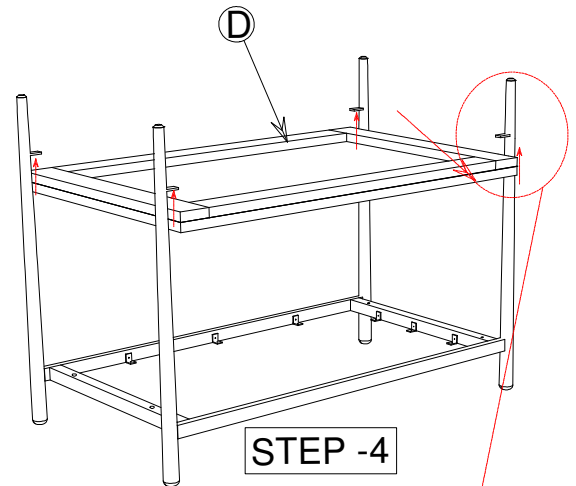

STEP -4

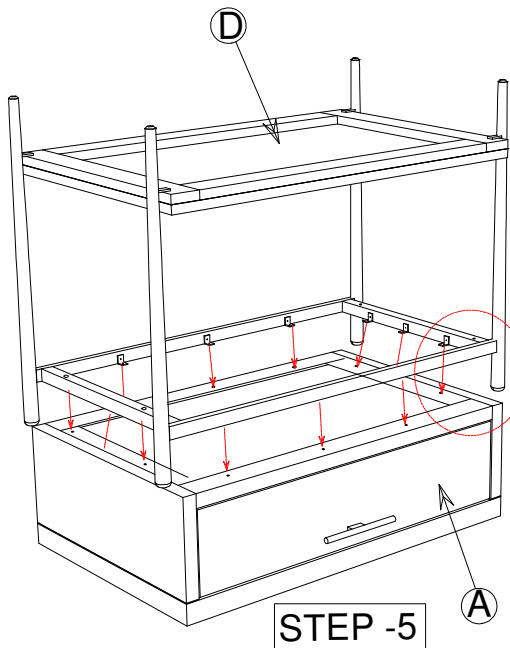

STEP -5

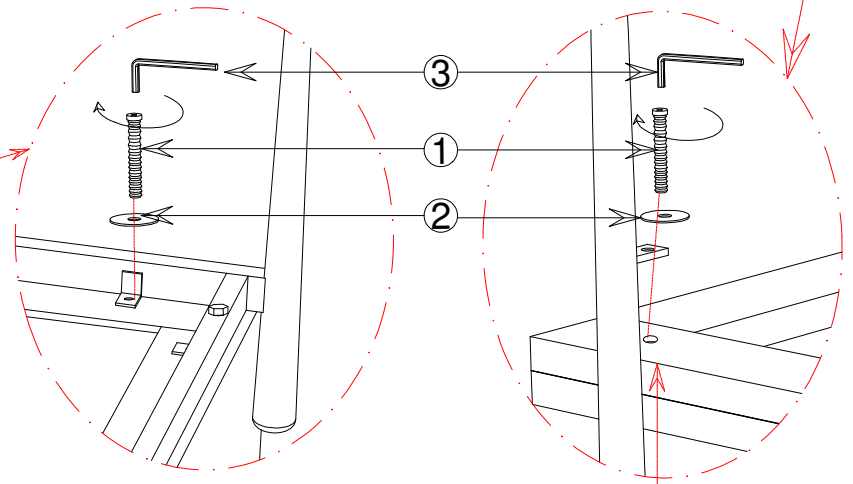

TO ASSEMBLY :

- STEP 1 : Unpack end table and remove drawer.
- STEP 2 : Roll end table on its back, then its top on a clean, soft surface.
- STEP 3 : Thread the HEX. bolt(4) to iron leg(B) & iron cross bar(C). using small washers(6) tighten metal base assembly fully.
- STEP 4 : Align holes in legs with holes on bottom of shelf (D) .
- STEP 5 : Attach legs to shelf with (1) JCB bolt and (1) washer # 2 with allen wrench #3.
- STEP 6 : Set base assembly on the upside down case and attach with JCB bolt (1) and washer (6) using allen wrench (3).
- STEP 7 : Tighten bolts in step 5 and 6 fully with allen wrench (3) & wrench (5) then carefully turn the end table upright.
- STEP 8 : Install drawers.