

C.I.D. III DOTS AND CAVITY NUMBER TO APPEAR ON HEEL. CAVITY NUMBER TO BE .156 [3.97] TALL.

HEEL LETTERING TO APPEAR ON SIDE OPPOSITE C.I.D. III DOTS, AND TO BE .156 [3.97] TALL

OPTIONAL:  
BOTTOM PLATE LETTERING TO BE .250 [6.35] TALL, WITH BAR BELOW LETTERING.

CRESCENT KNURLING TO APPEAR ON BEARING SURFACE.

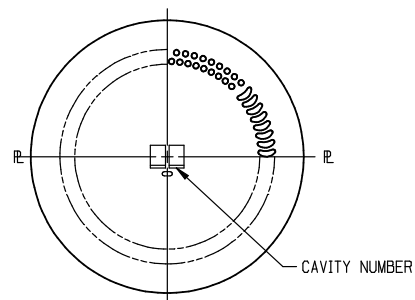

FINISH	OVERFLOW CAPACITY	WEIGHT	F.P. DN. IN.
038-0439-RB00	19.280 fl. oz. ± 0.250 fl. oz. [570.18ml ± 7.39 ml]	11.000oz. ± 0.500oz. [311.84g ± 14.17g]	2.453 [62.31]

**DISCLAIMER**

THIS INFORMATION IS PROVIDED AS A GENERAL GUIDE, INCLUDING DIMENSIONS. IT IS THE CUSTOMER'S RESPONSIBILITIES TO SELECT THE PROPER CONTAINER FOR PRODUCT AND APPLICATION COMPATIBILITY.

DISTRIBUTED BY:



REF NO.:

DWG30640

DESCRIPTION:

500 cc Glass Boston Round, 38-439