



# BRUTE ROLLOUT WITH CASTERS

BRUTE Rollouts with Casters are ideal for collecting, consolidating, and transporting heavy facility waste. Front swivel casters distribute weight evenly for superior mobility and handling.

## Features and Benefits:

- Heavy-duty wheels with high-performance treads are optimized for use indoors and outdoors
- Reinforced rim for superior structural integrity and robust lid designed for added strength
- Rollout lids open fully and stay in place to prevent swinging during transport
- Compliant with ANSI Standard Z245.60 (Types B and G) for compatibility with auto-lifters
- Smooth contours and seamless construction make cleaning easier and quicker, to improve staff productivity
- Designed with an ergonomic handle for comfortable push or pull operation
- High-quality materials plus a UV inhibitor extend the life of the container
- Swivel casters at the front of the container allow for more controlled use

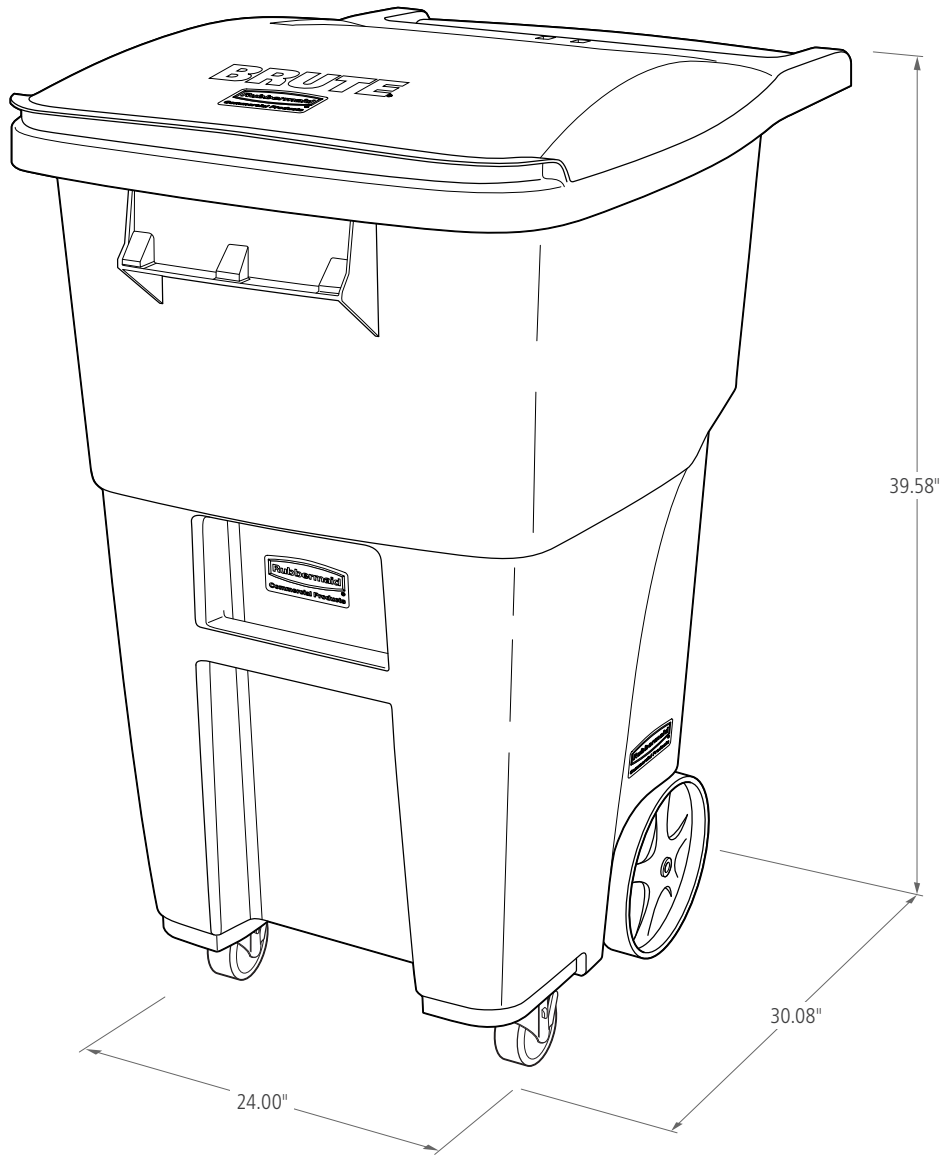

BRUTE 50-Gallon Rollout with Casters

## BRUTE ROLLOUT WITH CASTERS

SKU #	DESCRIPTION	COLOR	CAPACITY	LENGTH	WIDTH	HEIGHT	WEIGHT	PACK SIZE
			GAL					
1971947	BRUTE 32G ROLLOUT WITH CASTERS	GRAY	32G	28.56	20.62	37.16	20.70	2
1971949	BRUTE 32G ROLLOUT WITH CASTERS	BLUE	32G	28.56	20.62	37.16	20.70	2
1971959	BRUTE 50G ROLLOUT WITH CASTERS	GRAY	50G	30.08	24.00	39.58	29.00	2
1971961	BRUTE 50G ROLLOUT WITH CASTERS	BLUE	50G	30.08	24.00	39.58	29.00	2
1971971	BRUTE 65G ROLLOUT WITH CASTERS	GRAY	65G	32.33	25.33	44.74	36.00	1
1971973	BRUTE 65G ROLLOUT WITH CASTERS	BLUE	65G	32.33	25.33	44.74	36.00	1
1971994	BRUTE 95G ROLLOUT WITH CASTERS	GRAY	95G	37.15	28.60	46.02	44.00	1
1971996	BRUTE 95G ROLLOUT WITH CASTERS	BLUE	95G	37.15	28.60	46.02	44.00	1

