

BLACK DIAMOND®

Project Name: _____

Location: _____

Item #: _____

Qty: _____

Black Diamond Refrigerated Chef Base, 2 Drawers, 10.6 cu ft, in Stainless Steel

USCB-52



Increase efficiency in your commercial kitchen with the Black Diamond Refrigerated Chef Base, expertly crafted for reliable performance and streamlined food storage. The heavy-duty stainless steel construction offers durability and easy cleaning, while electronic controls and a slide-out compressor simplify operation and maintenance. This 2-drawer chef base refrigerator provides a spacious 10.6 Cu. Ft. capacity for ingredient organization within a temperature range of 33° to 40°F, using eco-friendly R290 refrigerant for sustainable operation. The refrigerated chef base is backed by a two-year parts and labor warranty plus a five-year compressor warranty, ensuring long-term peace of mind.

FEATURES AND CONSTRUCTION

- Boasts a 10.6 Cu. Ft. capacity for ample storage needs
- Equipped with a 1/6 horsepower side-mounted slide-out compressor for reliable cooling performance
- Constructed with heavy-duty stainless steel exterior, top, and drawers for superior durability and easy cleaning
- Maintains a precise temperature range of 33° to 40°F for optimal food preservation
- Features two stainless steel drawers with smooth glides for secure ingredient access and organization
- Includes two removable drawers, each accommodating up to three full-size food pans
- Equipped with four 4-inch locking casters for easy maneuverability and cleaning
- Slide-out compressor allows easy maintenance
- Foamed-in-place polyurethane insulation enhances efficiency

ELECTRIC

115V / 60Hz / 1Ph

Cord Length (Inches): 98.40"

Plug Type: NEMA 5-15P

Cord set included

NEMA 5-15P



3RD PARTY APPROVALS



WARRANTY (USA / CANADA)

Two (2) Year Limited Warranty on Parts and Labor, Five (5) Year Warranty on Compressor and Evaporator

Contact us for details at 1.877.368.2797



STORAGE CAPACITY

- Cubic Feet: 10.6 Cu. Ft.
- 6 Full Size Pans

TEMPERATURE

- Holding Temperature (Fahrenheit): 33° - 40°
These models are designed to operate in an environment where temperature and humidity do not exceed 75°F (24°C) and 55% relative humidity



Black Diamond 2 Drawer Refrigerated Chef Base

USCB-52

FRONT

SIDE

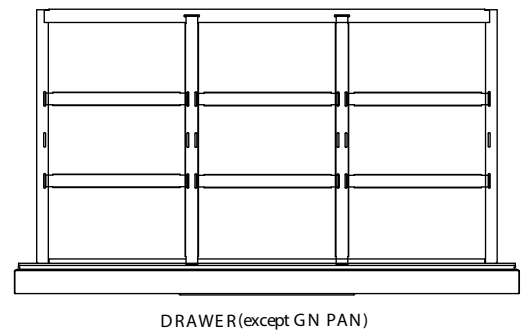
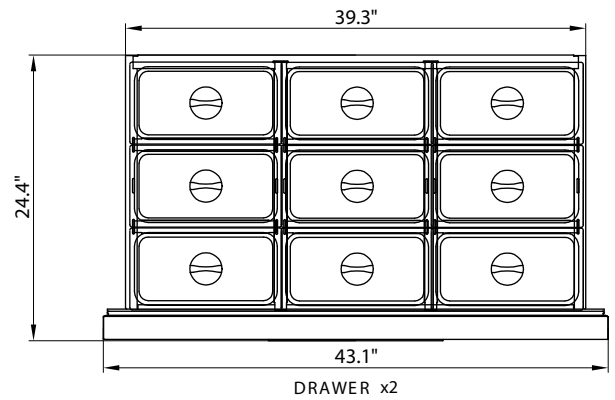
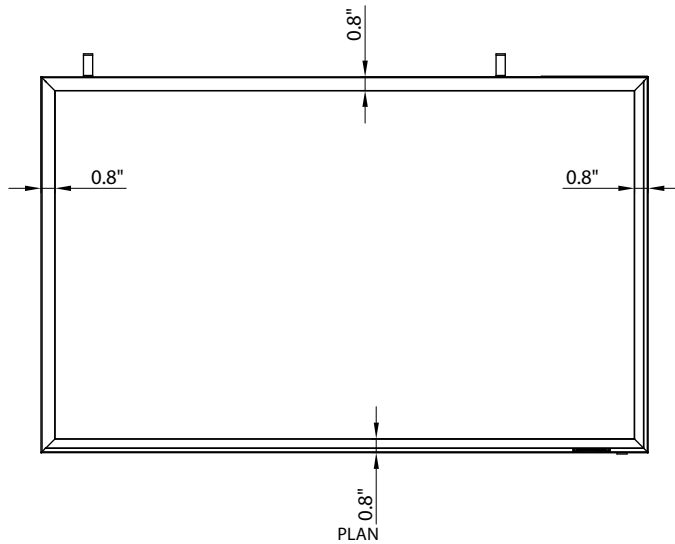
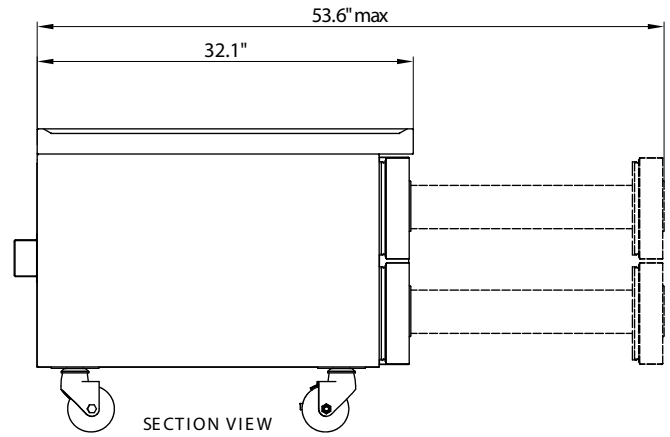
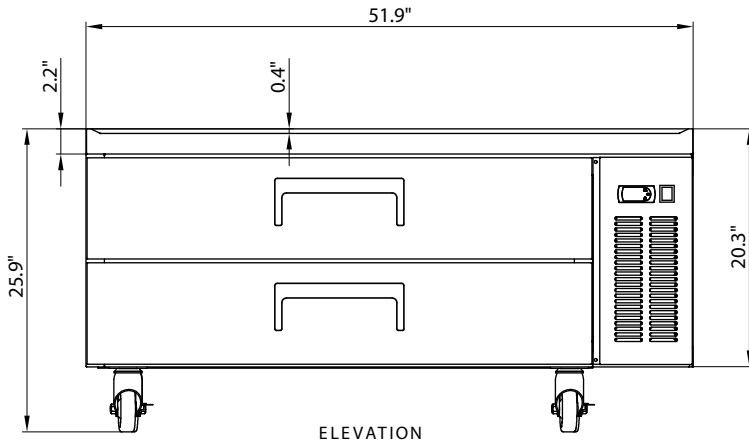

TOP

Chef Base

Drawers	Top Weight Limit (lbs)	Amps	HP	Refrigerant Type / Oz.	Assembled Dimensions (in)	Item Weight (lbs)	Shipping Weight (lbs)
2	717 lbs	4.5A	1/6	R290 3.177 oz	32.10" x 51.90" x 25.90"	220.0	279.0

Due to periodic changes in designs, methods, procedures, policies and regulations, the specifications contained in this document are subject to change without notice. While we exercise good faith efforts to provide information that is accurate, we are not responsible for errors or omissions in information provided or conclusions reached as a result of using the specifications. By using the information provided, the user assumes all risks in connection with such use.