

BLACK DIAMOND®

Project Name: _____

Location: _____

Item #: _____

Qty: _____

Black Diamond Insulated Warming Proofing and Hot Holding Cabinet, 4.94 Cu. Ft. Capacity, in Silver

BDPW14IF



Designed for restaurants, bakeries, and foodservice operations, the Black Diamond Insulated Warming Proofing and Hot Holding Cabinet offers optimal versatility for proofing dough and keeping baked goods warm. Its freestanding design and durable aluminum and plastic construction ensure long-lasting reliability and easy mobility with 5" casters and corner bumpers. The adjustable knob controls support two operation modes with nine power levels, maintaining consistent temperatures from 86°F to 203°F for a variety of holding and proofing needs. The unit accommodates up to twelve full-size 18" x 26" sheet pans with a 4.94 Cu. Ft. capacity, maximizing storage while saving space. With a reversible clear PC door for flexible installation, easy access, and enhanced visibility, this hot holding cabinet streamlines workflow in busy environments.

FEATURES AND CONSTRUCTION

- Constructed from corrosion-resistant aluminum and plastic for enhanced durability and performance
- Electrical operation powered by 1440 watts on a 120V single-phase circuit
- Fitted with twelve non-adjustable shelf supports for full-size sheet pans
- User-friendly knob controls with clear settings for proofing and holding modes
- Electric-powered cabinet designed for efficient hot holding and dough proofing
- Freestanding unit with 5" casters and corner bumpers for easy mobility and protection
- Manual knob activation with consistent temperature retention and operational safety
- Offers adjustable temperature range from 86°F to 203°F
- Unit dimensions: 23" W x 33" D x 32" H, weighing 93.70 lbs

ELECTRIC

120V / 60Hz / 1Ph

Cord Length (Inches): 78.70

Plug Type: NEMA 5-15

Cord set included

NEMA 5-15P



3RD PARTY APPROVALS



WARRANTY (USA / CANADA)

One (1) Year Limited Warranty on Parts and Labor

Contact us for details at 1.877.368.2797



TEMPERATURE

- Temperature Range (Fahrenheit): 86 - 203

INCLUDED COMPONENTS

- Corner bumpers, 5" casters



Black Diamond Insulated Warming Proofing and Hot Holding Cabinet

BDPW14IF

FRONT

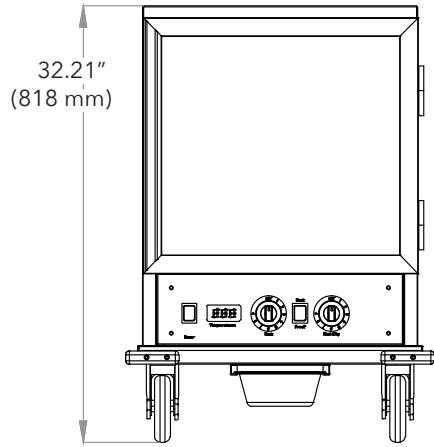

SIDE

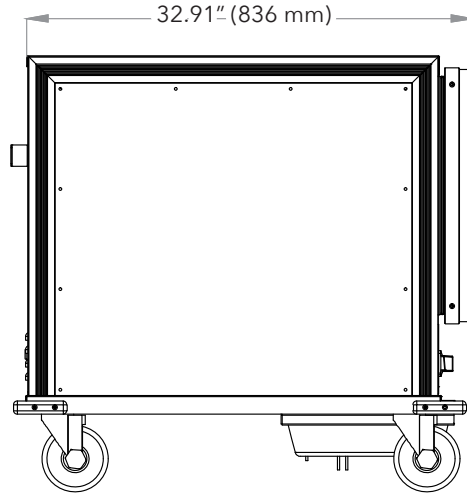

TOP

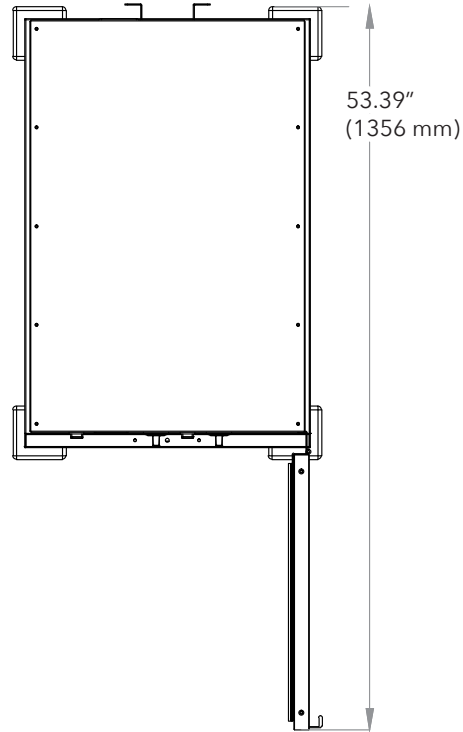
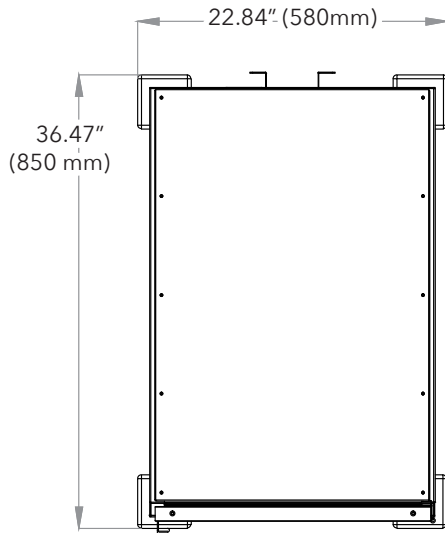

Proofing and Hot Holding Cabinet

Control Type	Amps	Wattage	Shelves	Capacity	Assembled Dimensions L x W x H (in)	Item Weight (lb)	Shipping Weight (lb)
Knob	12	1440	12	4.94 Cu. Ft. (12) Full Size, 18" x 26" Sheet Pans	33.00" x 23.00" x 32.00"	93.7	127.8

Due to periodic changes in designs, methods, procedures, policies and regulations, the specifications contained in this document are subject to change without notice. While we exercise good faith efforts to provide information that is accurate, we are not responsible for errors or omissions in information provided or conclusions reached as a result of using the specifications. By using the information provided, the user assumes all risks in connection with such use.