



Manufactured by:  
Backyard Discovery  
3305 Airport Drive, Pittsburg, KS 66762  
800-856-4445

*Basepoint Business Centre: Rivermead Drive, Westlea, Swindon SN5 7EX Phone: 0800-118-2476 J.P.  
Coenstraat 7, The Bridge, The Hague, 2595 WP, Netherlands Phone: 08005678990*

# FUSION FIRE GUTTER KIT

**MODEL #: 9250178**



**Please visit [www.backyarddiscovery.com](http://www.backyarddiscovery.com)**

**For the most up to date assembly manual, to register your product, or to order**

**replacement parts Para obtener instrucciones en español, visite**

**[www.backyarddiscovery.com](http://www.backyarddiscovery.com)**

# OWNER'S MANUAL - PARTS IDENTIFICATION

## Hardware Components

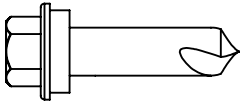

H101480 SCREW SELF TAPPING #9-1/4x1"  
(x13)



A6P01531 10 OZ SILICONE TUBE  
(x1)



H101414 SCREW SELF PIERCING #8x1/2 BLK  
(x5) #8 x 1/2

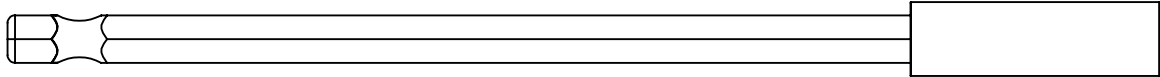

H101278 6" MAGNETIC DRIVER EXTENSION  
(x1)

## Accessory Components (NOT TO SCALE)

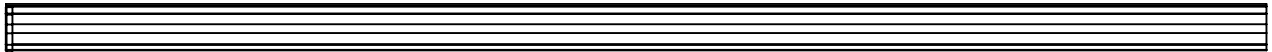

A4M06242 GUTTER - LEFT SIDE  
(x1) 3 11/16"x5 1/8"x98 7/16" [94x130x2500]

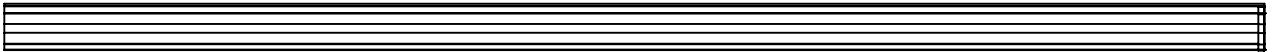

A4M06241 GUTTER - RIGHT SIDE  
(x1) 3 11/16"x5 1/8"x98 7/16" [94x130x2500]



A4M06685 DOWNSPOUT - 66"  
(x1) 2"x3"x66" [51x76x1625]

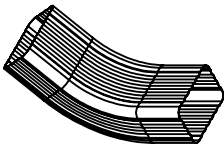

A4M06238 DOWNSPOUT ELBOW - LONG  
(x1) 3"x10 7/16"x10 11/16" [76x270x271]

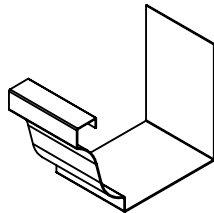

A4M04765 GUTTER SPLICE  
(x1) 2 1/2"x3 11/16"x5 1/16" [64x94x129]

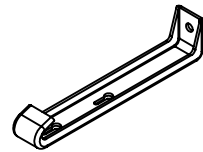

A4M04759 GUTTER HANGER  
(x9) 3/4"x1"x4 15/16" [19x25x125]

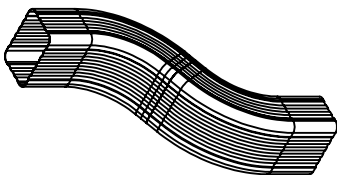

A4M05866 DOWNSPOUT OFFSET - 5IN  
(x1) 3"x7 3/16"x12 1/16" [76x183x306]

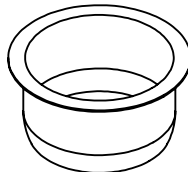

A4M04761 DOWNSPOUT OUTLET  
(x1) 1 7/16"x2 7/8" [37x73]

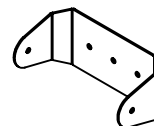

A4M04782 DOWNSPOUT CLIP  
(x2) 1 7/16"x1 7/16"x3 1/8" [37x37x79]

# PRE-ASSEMBLY STEP 1 - SORTING PARTS

It is critical for ease of assembly that you take the time to sort and organize the parts and hardware.

---

## **HARDWARE PARTS:**

- We recommend that you have a separate table to organize the hardware.
- Hardware bags are printed with a seven-digit, alpha-numeric part number.
- You can organize your hardware by part number or group by hardware type (e.g. bolts, nuts, etc.).
- During assembly you only need to reference the last four digits of the number.



---

## **TOOLS REQUIRED:**



Cordless Drill or  
Electric Drill



Caulk Gun



Tape Measure



1/8" Drill Bit

# GUTTER SPLICE PAGE

- NOTE:**
- APPLY SILICONE TO INSIDE CHANNEL ON BOTH SIDES.
  - ENSURE SILICONE IS EVENLY APPLIED ALONG THE CHANNEL.
  - AFTER GUTTER SPLICE HAS BEEN SLID ONTO GUTTERS AND SILICONE HAS HAD TIME TO CURE, USING HAND PRESSURE ONLY, FOLD THE TOP TAB OVER EDGE OF GUTTER

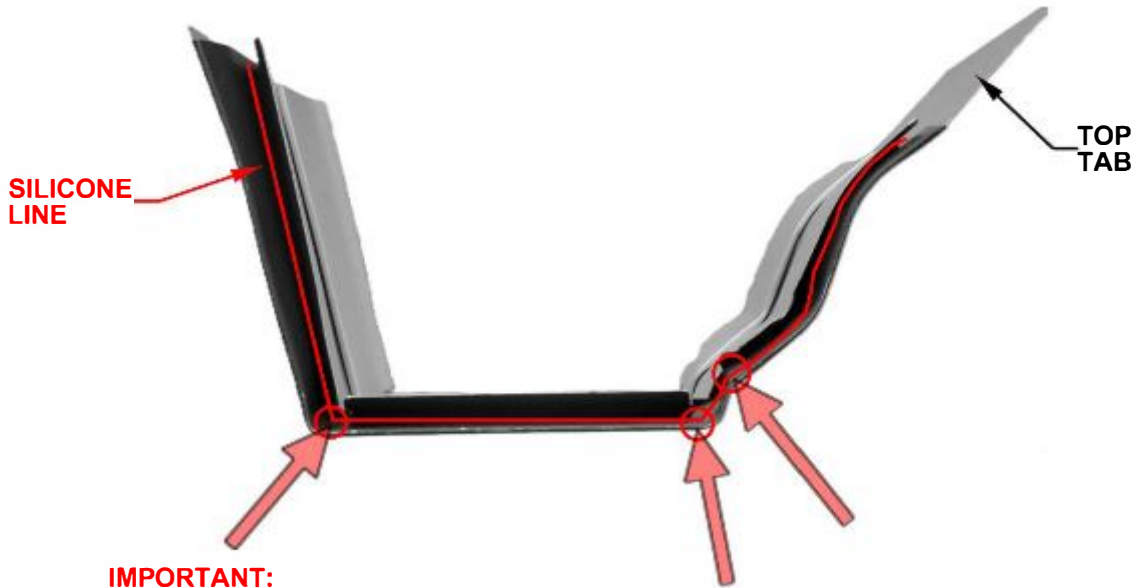

- IMPORTANT:**
- APPLY SILICONE LIBERALLY INTO CORNERS AS INDICATED ABOVE.

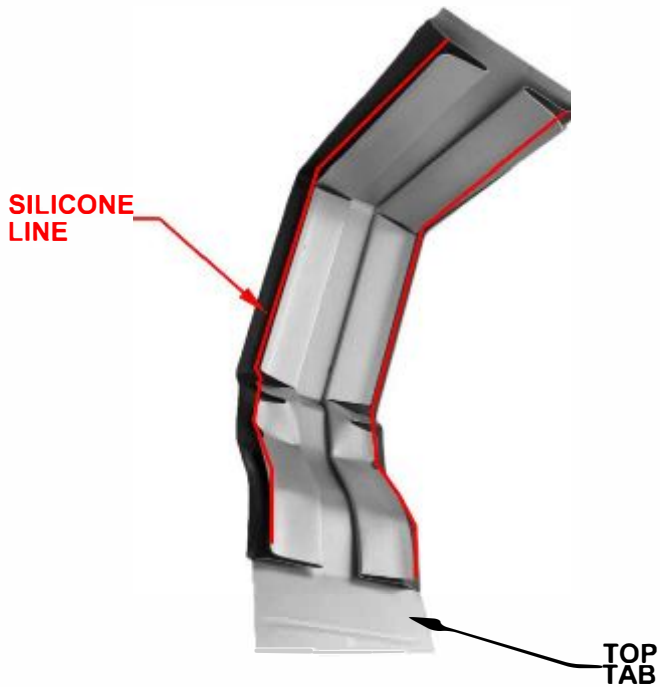

WAIT APPROXIMATELY 45 MINUTES FOR SILICONE TO BECOME TACKY.  
AFTER 24 HOURS, SILICONE HAS CURED AND CAN HOLD WATER

# OFFSET ORIENTATION

TO ENSURE WATER FLOWS PROPERLY, IT IS IMPORTANT TO ORIENT DOWNSPOUT PIPING CORRECTLY. STARTING AT THE TOP, DOWNSPOUTS MUST FEED INTO THE NEXT SECTION AS SHOWN.

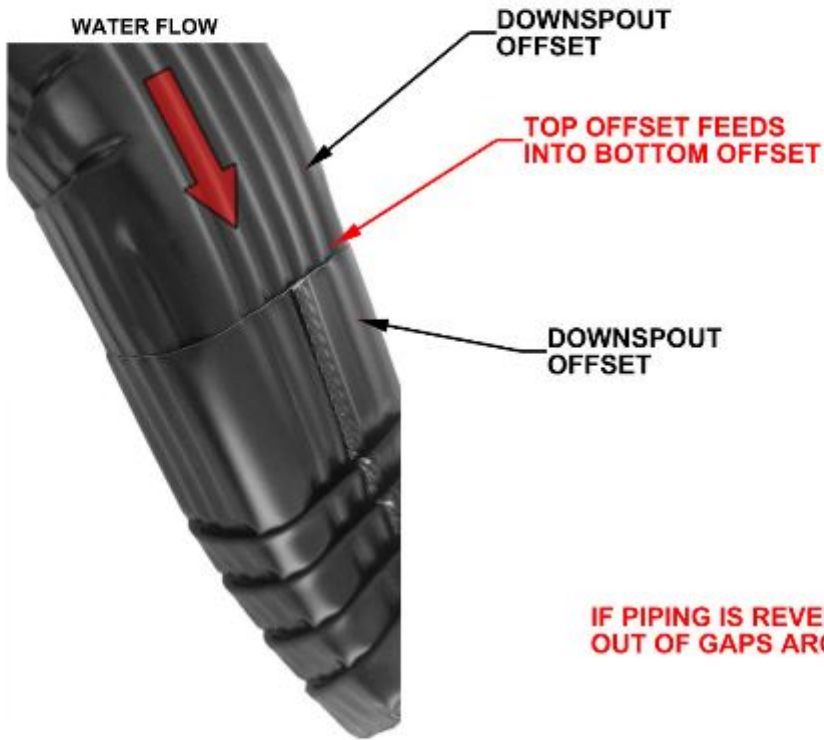

IF PIPING IS REVERSED, WATER WILL RUN OUT OF GAPS AROUND JOINTS



# STEP 1 - GUTTER ASSEMBLY

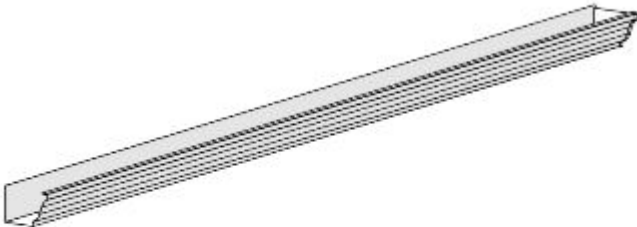

A4M06241 GUTTER - RIGHT SIDE  
(x1)

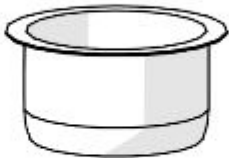

A4M04761 DOWNSPOUT OUTLET  
(x1)

- APPLY A BEAD OF SILICONE AROUND THE BOTTOM LIP OF THE DOWNSPOUT OUTLET AND PLACE OUTLET INSIDE GUTTER.

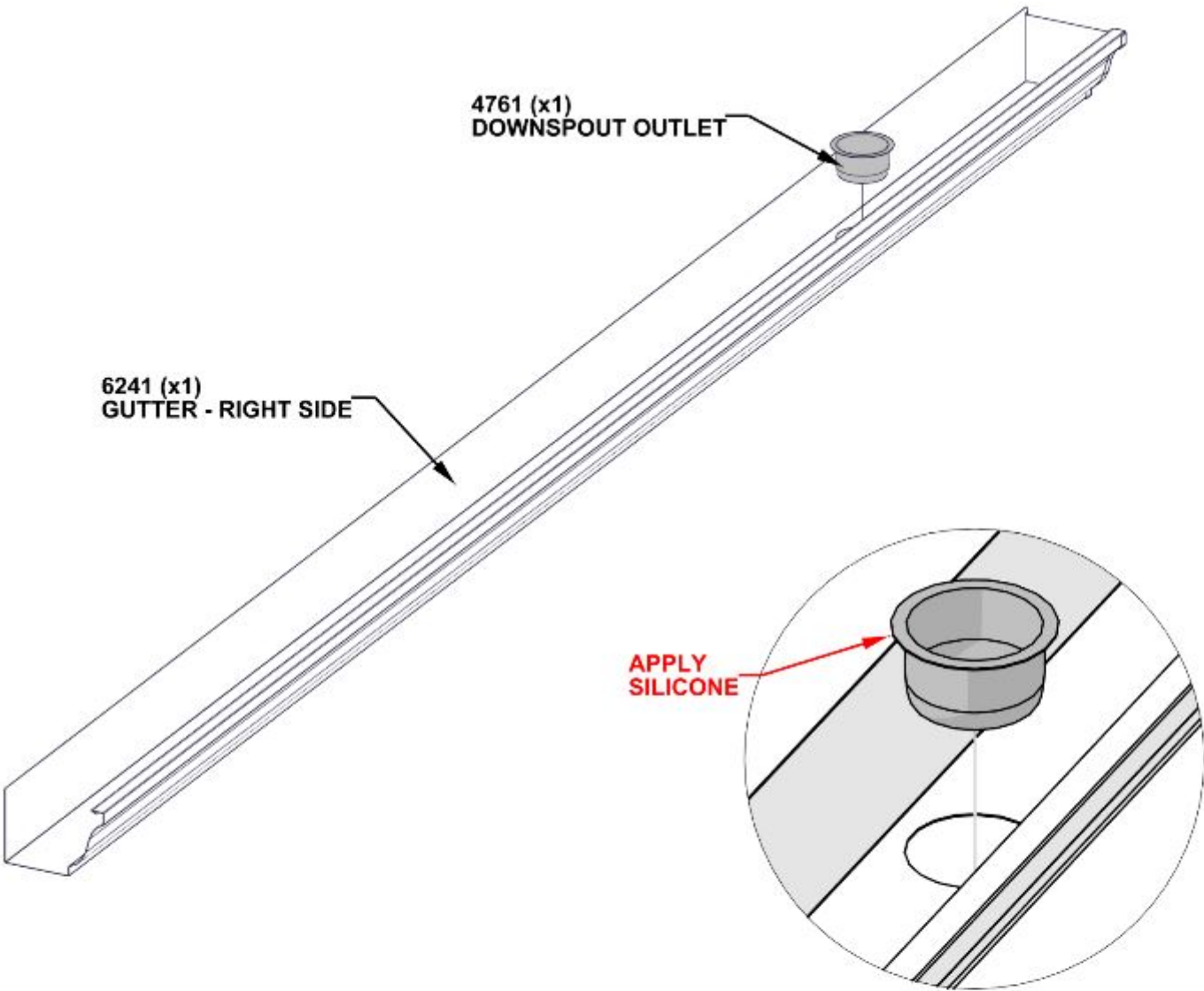

# STEP 2 - GUTTER ASSEMBLY

LAY GUTTERS ON THE GROUND TO DETERMINE WHERE GUTTERS WILL BE INSTALLED. DOWNSPOUT MUST BE CENTERED ON POST.

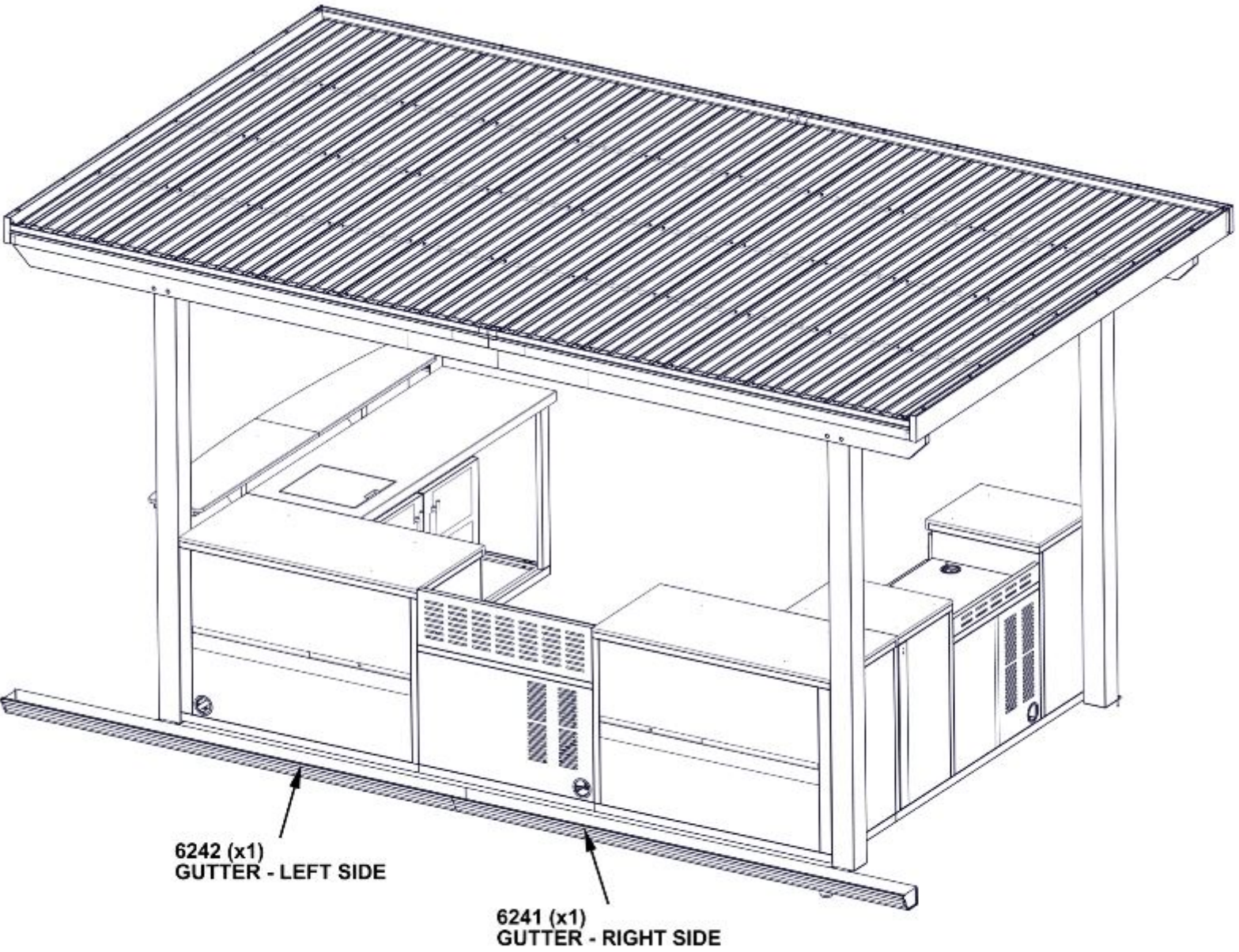

# STEP 3 - GUTTER ASSEMBLY

QTY	PART NUMBER	DESCRIPTION
2	H101480	SCREW SELF TAPPING #9x1 BLK



GUTTER ASSEMBLY W/ OUTLET - STEP 1

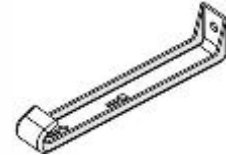

A4M04759 GUTTER HANGER (x2)

- SLIDE GUTTER ASSEMBLY UP UNDER EDGE TRIM AND FLUSH BOTTOM OF GUTTER WITH METAL BEAM.
- CENTER DOWNSPOUT OUTLET WITH POST.
- INSTALL A GUTTER HANGER 2-3/8" [60mm] FROM THE EDGE OF THE ROOF
- INSTALL THE NEXT GUTTER HANGER 8 RIBS FROM THE FIRST CLIP.
- USE A CLAMP TO HOLD GUTTER TO BEAM FOR ASSISTANCE.

PRE-DRILL HOLES WITH 1/8" [3mm] DRILL BIT FOR EASE OF ASSEMBLY

1480 (x2) SCREW - 1"

4759 (x2) GUTTER HANGER

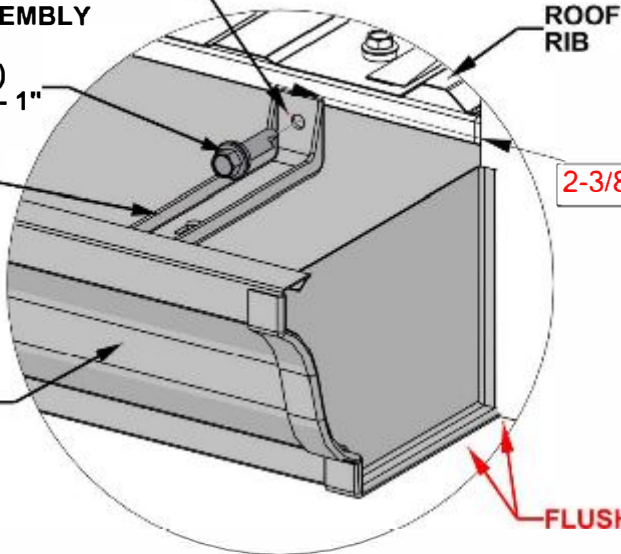

2-3/8" [60mm]

FLUSH

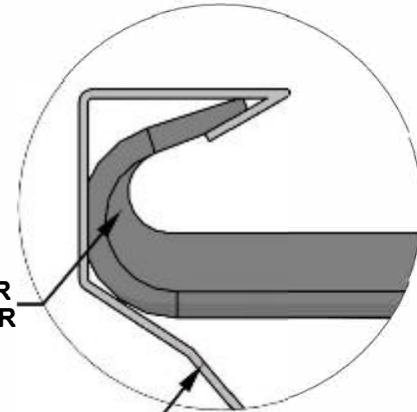

GUTTER HANGER

GUTTER

GUTTER ASSEMBLY W/ OUTLET - STEP 1

GUTTER HANGERS

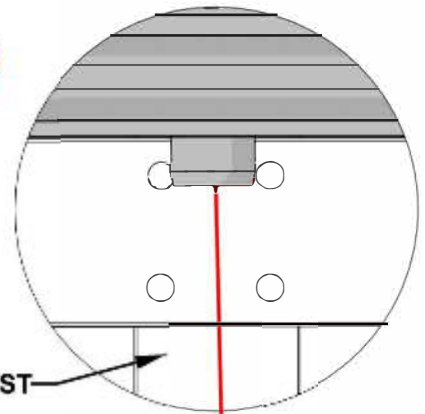

POST

CENTER DOWNSPOUT OUTLET ON POST

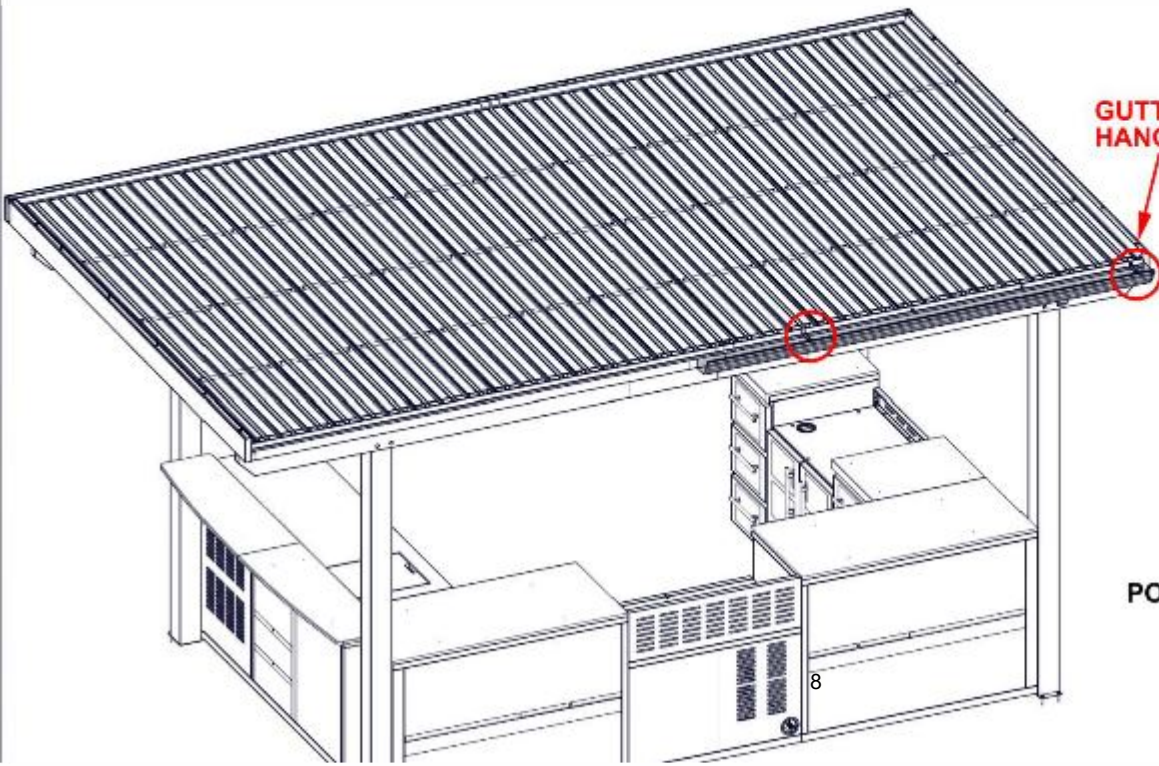

# STEP 4 - GUTTER ASSEMBLY

QTY	PART NUMBER	DESCRIPTION
2	H101480	SCREW SELF TAPPING #9x1 BLK

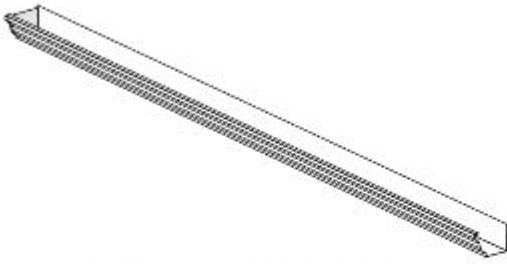

A4M06242 GUTTER - LEFT SIDE  
(x1)

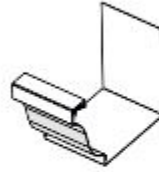

A4M04765 GUTTER SPLICE  
(x1)



A4M04759 GUTTER HANGER  
(x2)

- SLIDE GUTTER ASSEMBLY UNDER EDGE TRIM AND FLUSH BOTTOM OF GUTTER WITH METAL BEAM.
- INSTALL FIRST HANGER APPROXIMATELY 2-1/2" [60mm] FROM THE EDGE OF ROOF.
- INSTALL THE NEXT HANGER 8 ROOF RIBS FROM THE PREVIOUS.
- USE A CLAMP TO HOLD GUTTER TO METAL BEAM FOR ASSISTANCE.
- SEE CAULKING SHEET FOR DETAILS.

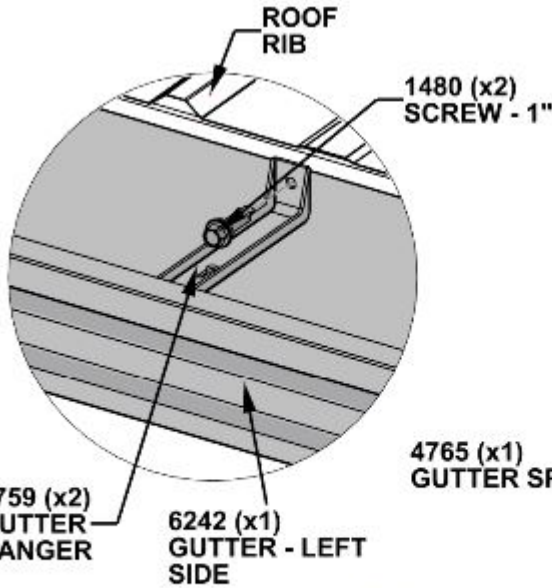

**APPLY 1531 SILICONE TO SPLICE GROOVE BEFORE INSERTING INTO GUTTER**

**APPLY SILICONE TO SPLICE GROOVE BEFORE INSERTING GUTTER INTO SPLICE**

PART 1:

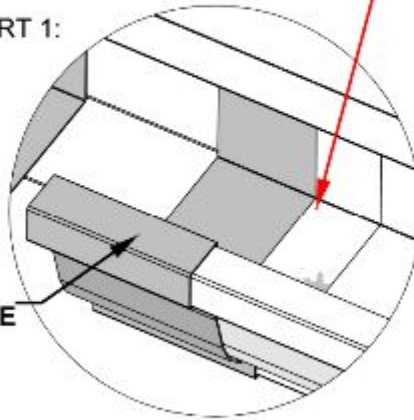

PART 2:

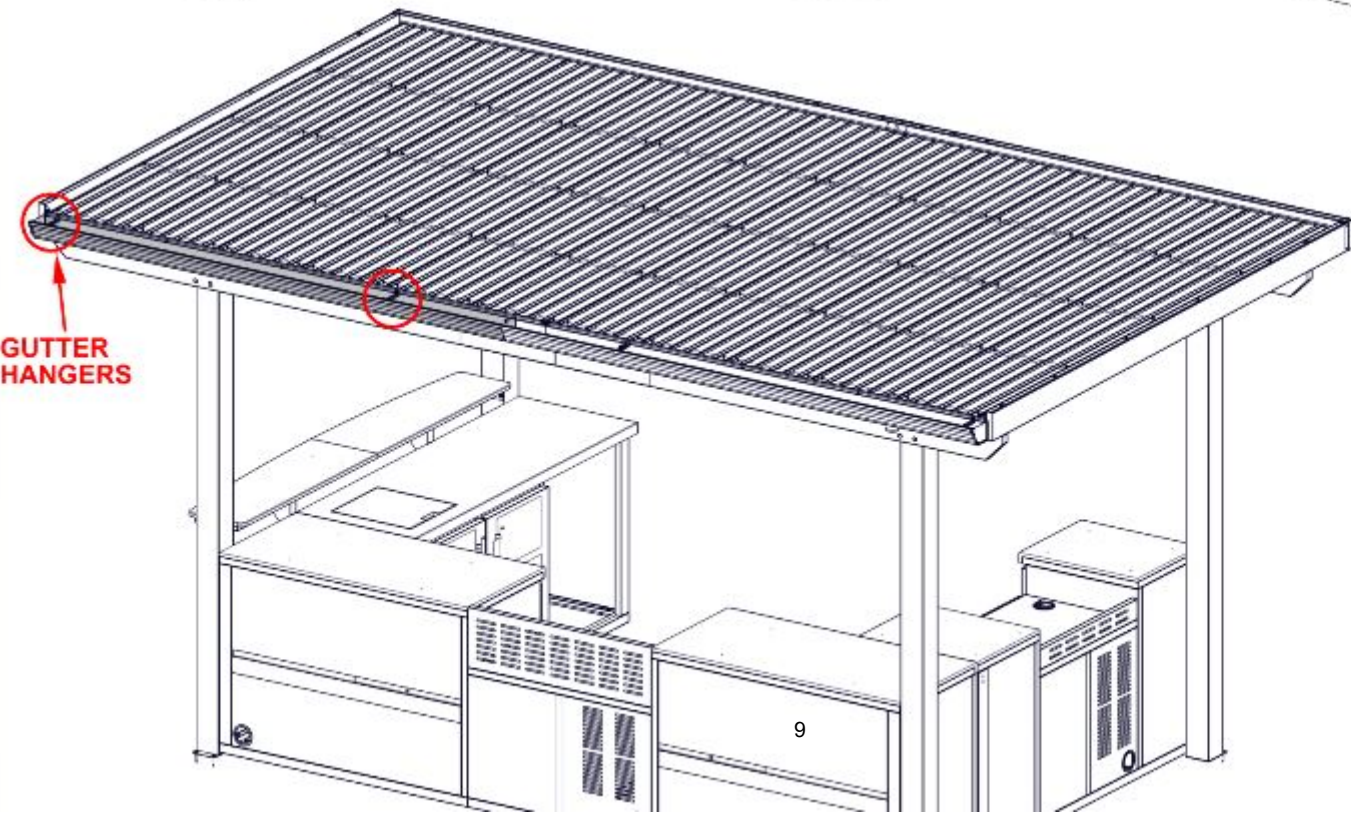
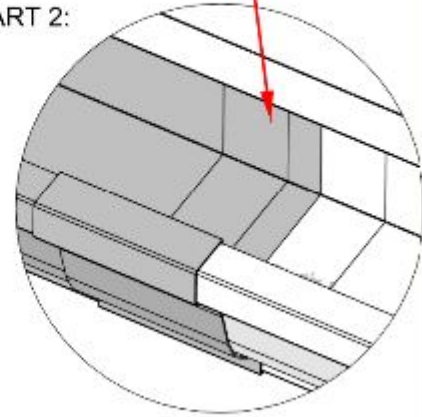

# STEP 5 - GUTTER ASSEMBLY

QTY	PART NUMBER	DESCRIPTION
4	H101480	SCREW SELF TAPPING #9x1 BLK

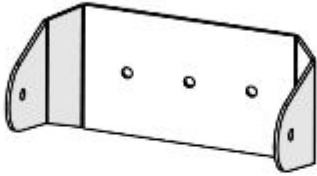

A4M04782 DOWNSPOUT CLIP  
(x2)

- IT IS IMPORTANT TO CENTER 4782 CLIP AND HARDWARE ON POST AS SHOWN.
- ATTACH GUTTER CLIPS APPROXIMATELY 7 7/8" [200mm] AND 79-3/4" [2025mm] OFF THE GROUND.

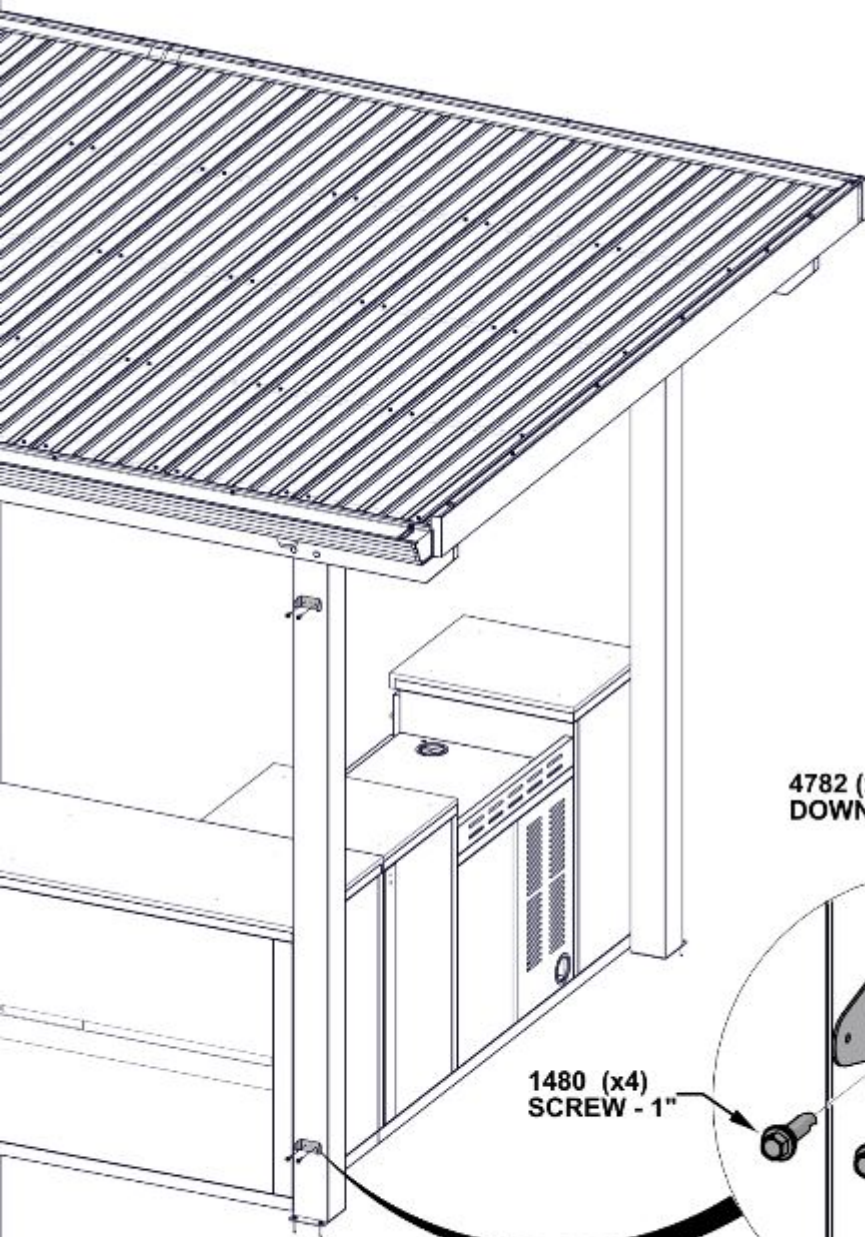

4782 (x2)  
DOWNSPOUT CLIP

1480 (x4)  
SCREW - 1"

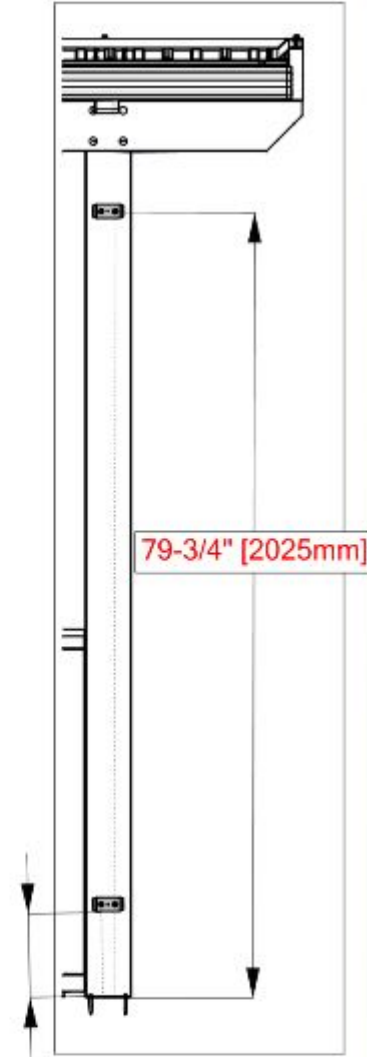

79-3/4" [2025mm]

7-7/8" [200mm]

# STEP 6 - GUTTER ASSEMBLY



A4M05866 DOWNSPOUT OFFSET - 5IN  
(x1)



A4M06238 DOWNSPOUT ELBOW - LONG  
(x1)



A4M06685 DOWNSPOUT - 66"  
(x1)

- INSERT TAPERED ENDS INTO LARGER ENDS AS SHOWN.
- NOTE ORIENTATION OF DOWNSPOUT OFFSET. SEE DOWNSPOUT OFFSET PAGE FOR DETAIL.

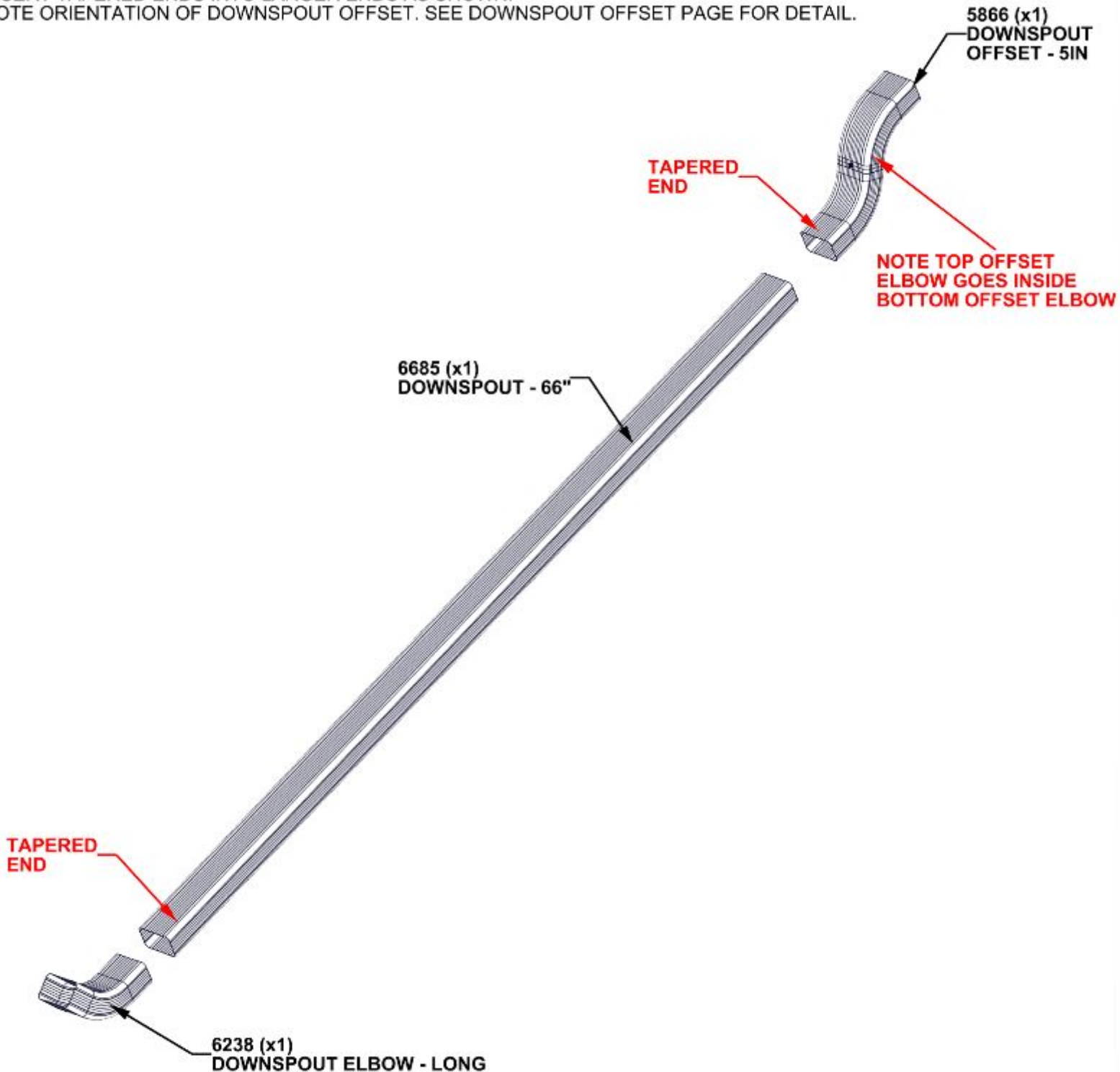

# STEP 7 - GUTTER ASSEMBLY

QTY	PART NUMBER	DESCRIPTION
1	H101414	SCREW SELF PIERCING #8x1/2 BLK



DOWNSPOUT ASSEMBLY - STEP 6

- SLIDE DOWNPOUT ASSEMBLY OVER GUTTER OUTLET AND ATTACH WITH HARDWARE PROVIDED.
- NOTE GUTTER WILL NOT EXTEND TO GROUND, THERE WILL BE FLOATING SPACE.

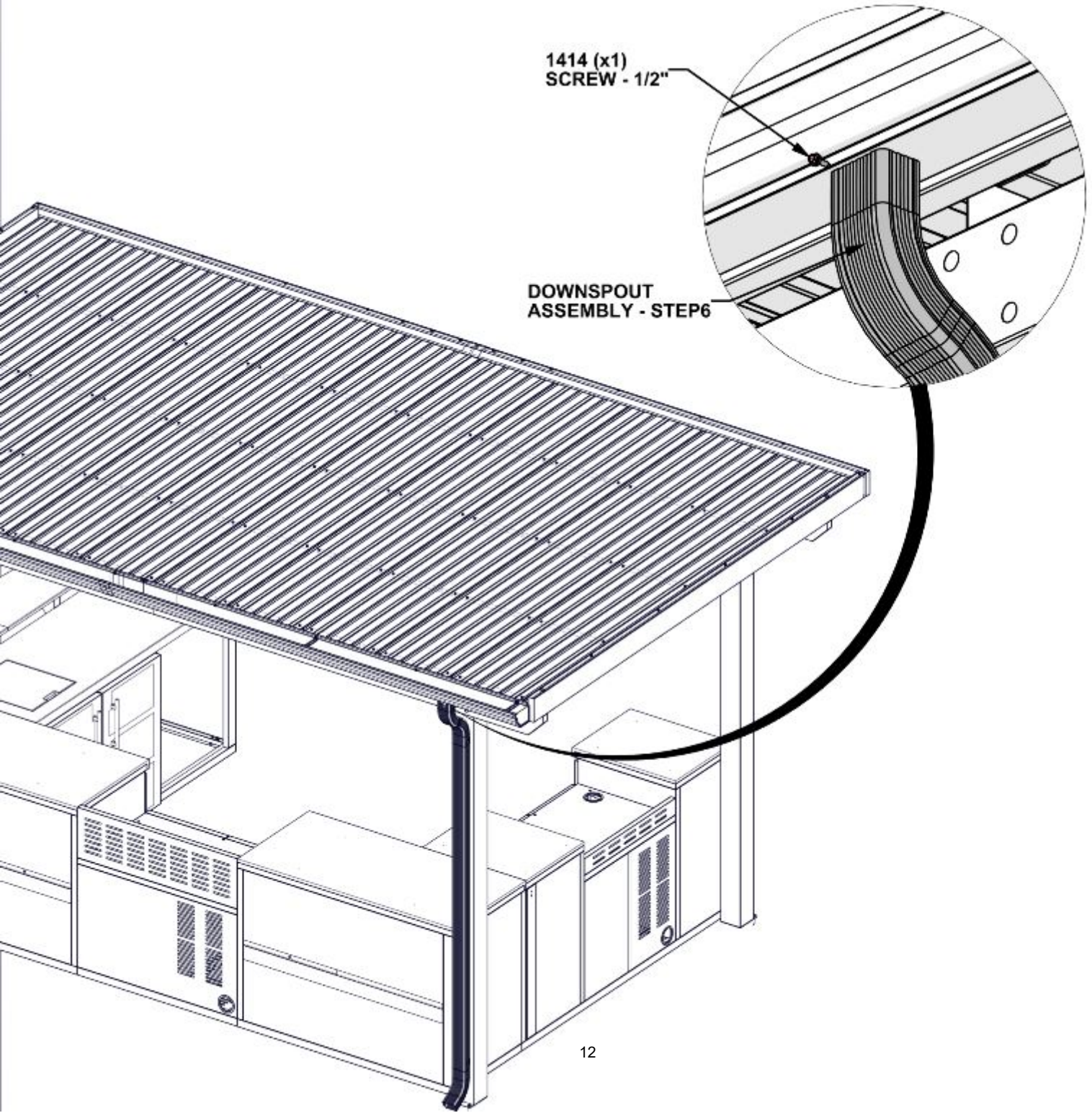

# STEP 8 - GUTTER ASSEMBLY

QTY	PART NUMBER	DESCRIPTION
4	H101414	SCREW SELF PIERCING #8x1/2 BLK

- FASTEN DOWNSPOUT CLIP TO DOWNSPOUT USING HARDWARE PROVIDED.

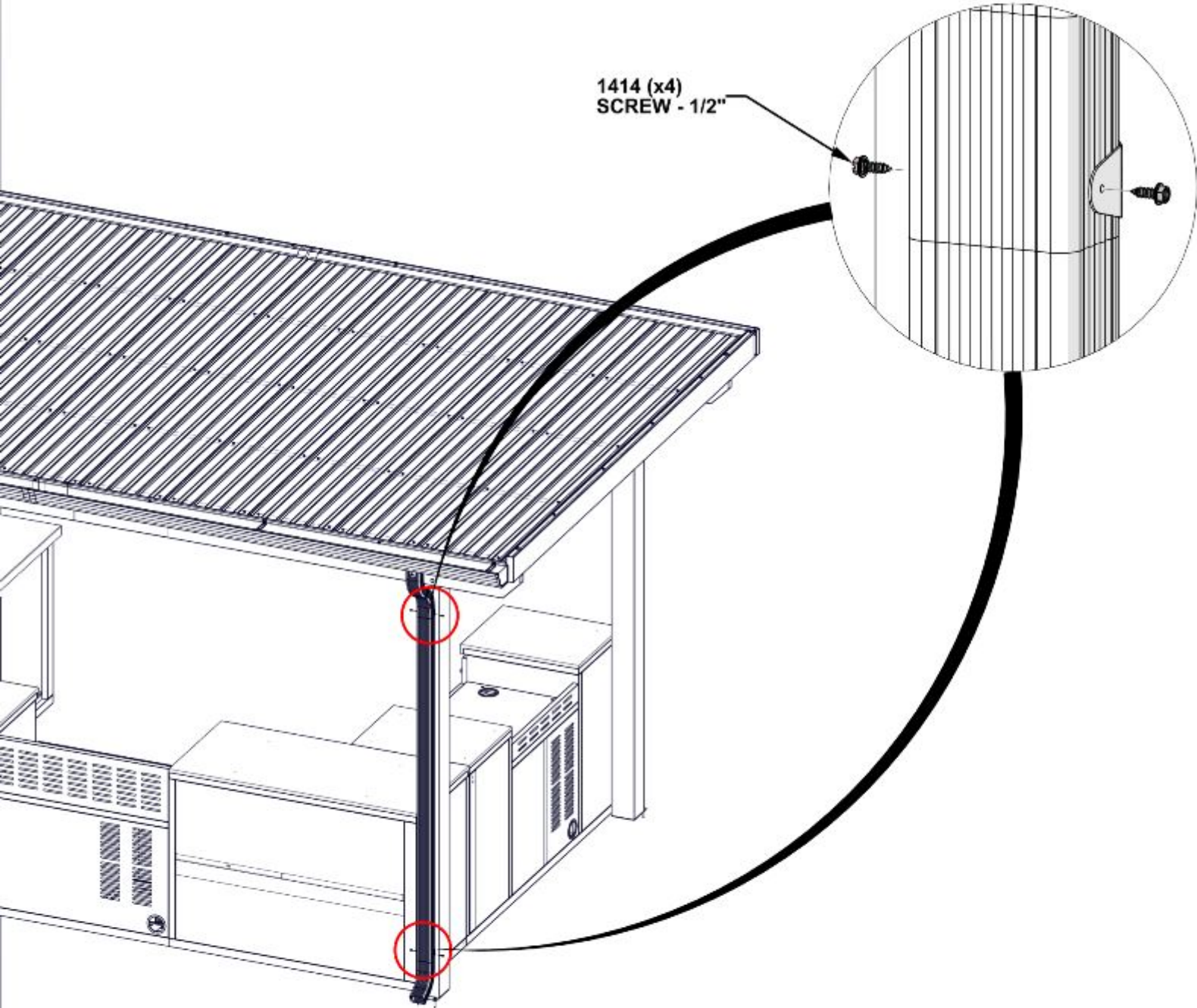

# STEP 9 - GUTTER ASSEMBLY

QTY	PART NUMBER	DESCRIPTION
5	H101480	SCREW SELF TAPPING #9x1 BLK

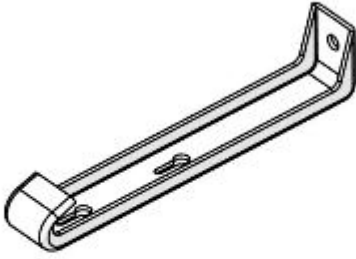

A4M04759 GUTTER HANGER  
(x5)

- ATTACH ALL REMAINING GUTTER CLIPS.
- IT IS RECOMMENDED TO START AT THE MIDDLE CLIP FIRST, THEN CENTER THE REMAINING CLIPS

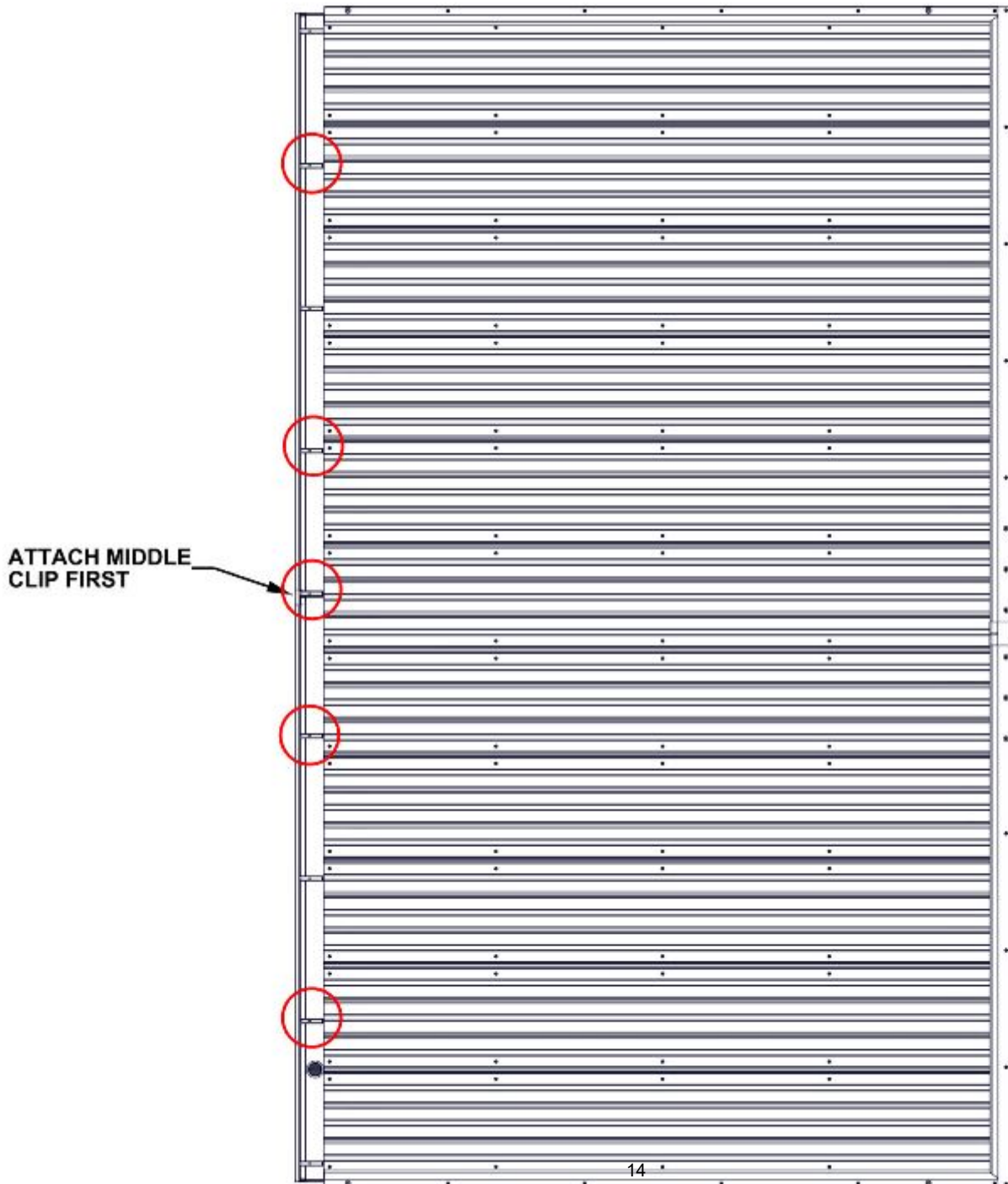

# STEP 10 - RE-CAULKING

- NOTE:**
- IT IS RECOMMENDED TO APPLY A SECOND BEAD OF SILICONE AT THE GUTTER SPLICE POSITION FROM EARLIER AFTER THE GUTTER KIT HAS BEEN INSTALLED.
  - BY WETTING ONES FINGER, GENTLY PUSH CAULK INTO SPLICE TAB AND CORNERS TO ENSURE PROPER SEALING.
  - SEE IMAGES BELOW FOR DETAIL.

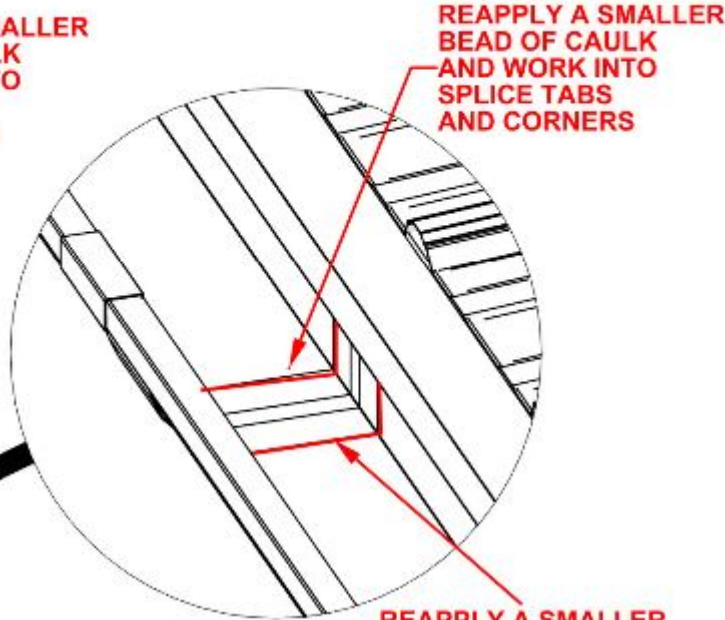
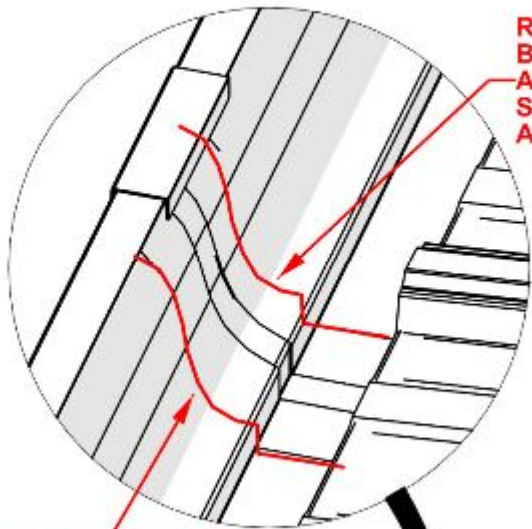
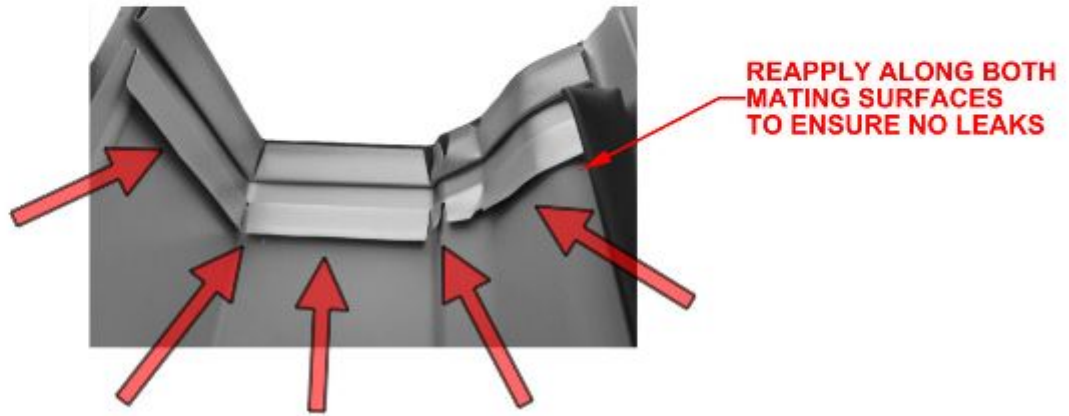

REAPPLY A SMALLER BEAD OF CAULK AND WORK INTO SPLICE TABS AND CORNERS

REAPPLY A SMALLER BEAD OF CAULK AND WORK INTO SPLICE TABS AND CORNERS

