



HEKMAN®

A HOWARD MILLER COMPANY

Assembly Instruction (28407) Wooden Carved Sunburst Design 2 Tone Cabinet

HARDWARE LIST			
No.	ITEM	DESCRIPTION	QTY
1		Allen Bolt M8X25	8
2		Allen Wrench	1

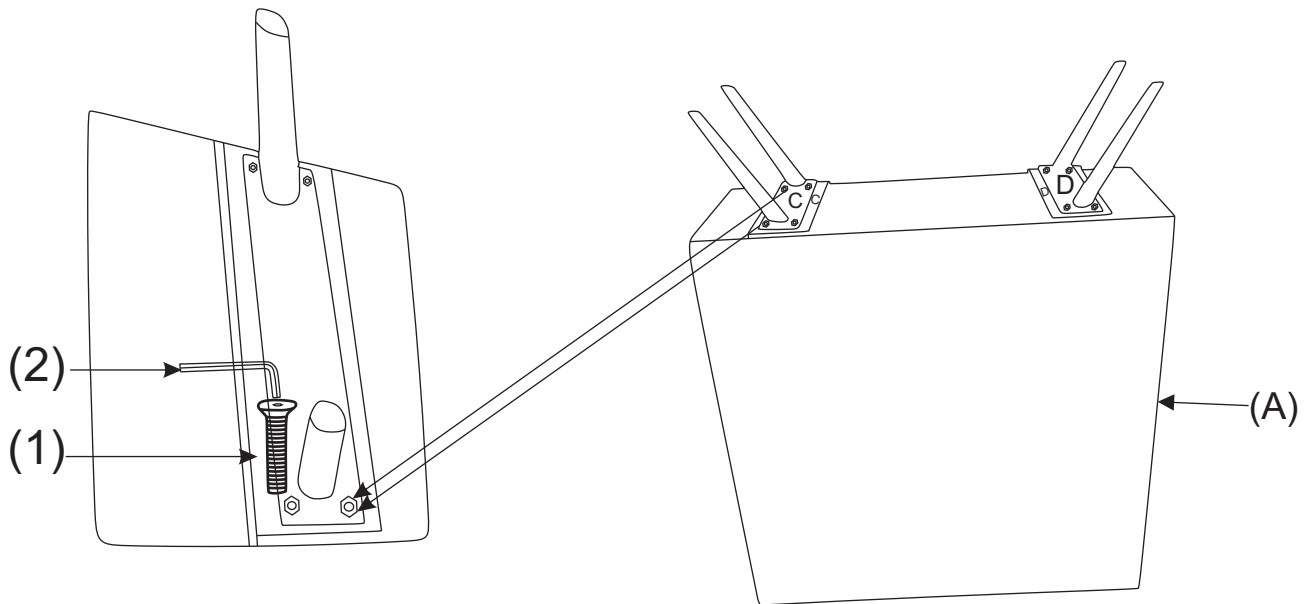
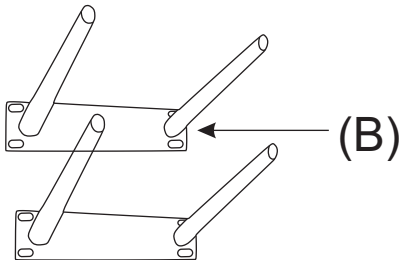
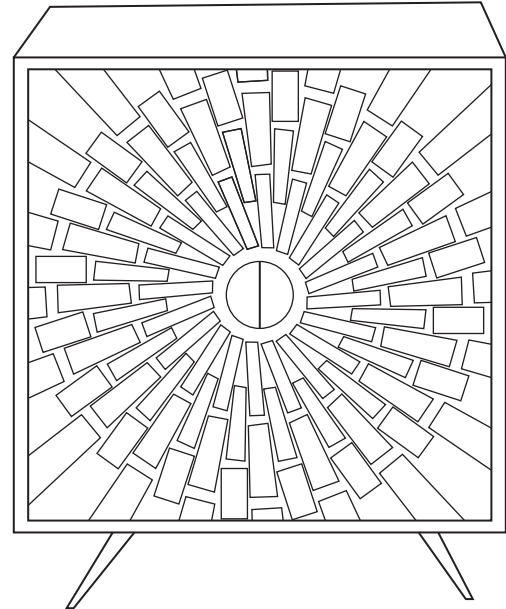

TO ASSEMBLE : (Two people required)

- Step : 1** Unpack the Cabinet.
- Step : 2** Roll the cabinet on its back then on its top on a clean soft surface.
- Step : 3** Set base assembly on the upside down case and attach with bolt (1) and using allen wrench (2)
- Step : 4** Align hole in cabinet (A) and legs (B)
- Step : 5** Attach two leg assemblies (B) by using eight Allen bolts.
(1) Then tighten with allen wrench (2) and the carefully upright the cabinet.