





# HEKMAN<sup>®</sup>

A HOWARD MILLER COMPANY

## ASSEMBLY INSTRUCTIONS FOR 25365 KING UPHOLSTERED HEADBOARD

### HARDWARE LIST

NO.	ITEM	DESCRIPTION	QTY	NO.	ITEM	DESCRIPTION	QTY
1		BOLT Ø1/4" x 1-1/2"	8	2		LOCK WASHER	8
3		FLAT WASHER	8	4		ALLEN WRENCH	1

### STEP 2

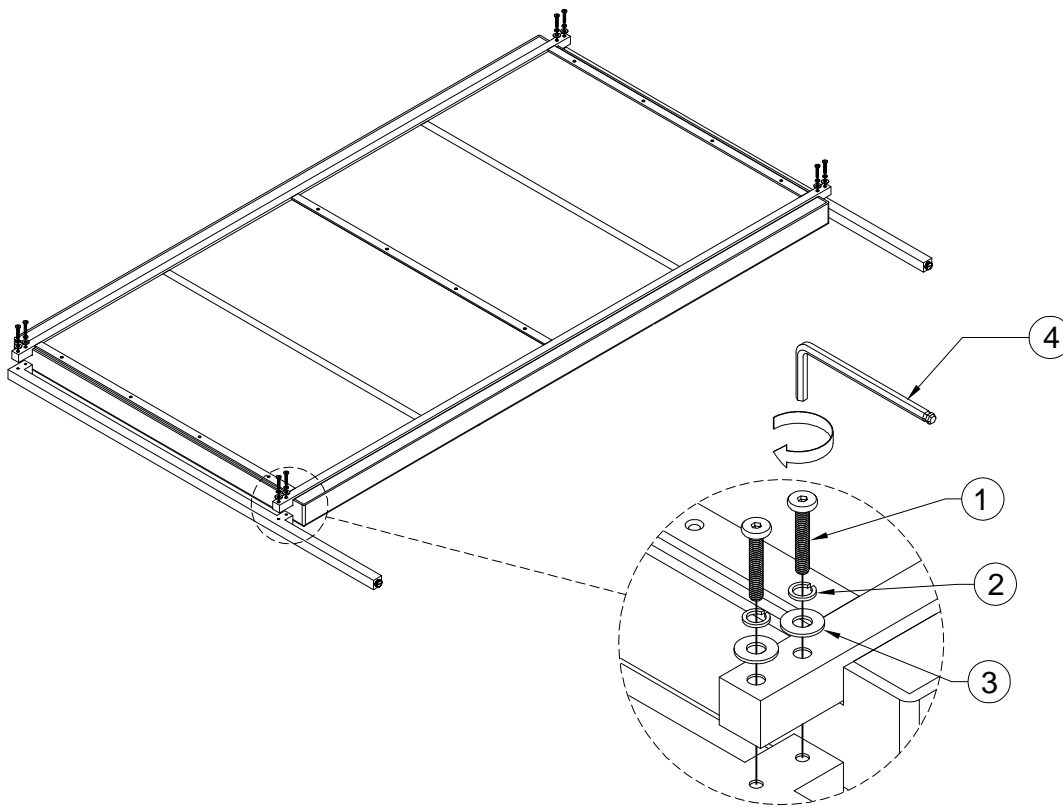

#### TO ASSEMBLY:

STEP 1: Lay the headboard face down on a piece of cloth or carpet to prevent the finish from scratching.

STEP 2: Attach the legs to the headboard. Insert the flat washer (3), lock washer (2), with medium bolt (1) to the headboard, tighten with allen wrench (4).

