

POWERLOK®

Monitored Rack Power Distribution Units (PDUs)

72", 20A 120/208V 3PH (5.7 kW), 10' Whip, NEMA L21-20P

Part Numbers

Item No. UP7101D 48-C13

Item No. UP7102D 36-C13 & 6-C19

Item No. UP7103D 48-C13, (2) 5-15R Tech Power

Item No. UP7104D 36-C13 & 6-C19, (2) 5-15R Tech Power



Carbon

Red White Blue

Applications

PowerLok® offers greater reliability, advanced functionality and an overall higher standard of rack PDUs for mission critical facilities. From unmatched convenience and delivery options at the ordering stage to the many unique customizations and modern design of the product itself, PowerLok® is the most feature-rich PDU on the market, at market competitive prices.

- Available in either basic or monitored (metered) models.
- Carbon color is standard.
- Red, white, and blue versions are available for orders over 24 (per SKU) and will have a lead time of 10–14 days (orders must be made in multiples of 6).
- Color options are also available for orders of 12 or 18 with a set-up charge.
- Patent-pending universal cord-locking solution, CordLok®, is also available for orders over 24 (per SKU) and will have a lead time of 10–14 days.



CordLok®

Features

- Automated soldering from line input to each receptacle for a more reliable connection.
- Fixed angled input whip with overhead or underfloor exit.
- Slim modern design — 2.18" W x 2" D.
- Greatest receptacle density — 48 C13 in a 72" PDU, 36 C19 in a 72" PDU.
- Highly visible group marking.
- Low profile receptacles protected from impact.
- Optional cord locking technology (CordLok®) that secures C13 and C19 cords.
- Simplified user interface with touchscreen display.
- Advanced monitoring, including internal temperature reporting.

Benefits

- 270% less likely to fail than rack PDUs with mechanical terminations (independently evaluated by MTechnology).
- Improves access to rear of server and IT equipment.
- More agile and aesthetically pleasing within IT equipment racks.
- Ease of installation.
- Easy insertion, retention, and detachment of plugs with a single hand with optional CordLok® technology.
- Reduces shipping cost and packaging waste with multi-pack packaging.
- Easy ordering and quick delivery—32 select models ship next day, 10,000+ built models ship within 10–14 business days.

Specifications

Part Number	Description	Receptacles	Dimensions	Quantity per Carton	Shipping Weight
UP7101D	Monitored Rack PDU	48-C13	72" x 2.18" x 2.0" (1829mm x 55mm x 51mm)	1	17 lbs.
UP7102D	Monitored Rack PDU	36-C13 and 6-C19	72" x 2.18" x 2.0" (1829mm x 55mm x 51mm)	1	17 lbs.
UP7103D	Monitored Rack PDU	48-C13, (2) 5-15R Tech Power	72" x 2.18" x 2.0" (1829mm x 55mm x 51mm)	1	17 lbs.
UP7104D	Monitored Rack PDU	36-C13 and 6-C19, (2) 5-15R Tech Power	72" x 2.18" x 2.0" (1829mm x 55mm x 51mm)	1	17 lbs.

- 20A 120/208V 3PH (5.7 kW).
- NEMA L21-20P plug.
- 10' Whip Length.
- The carbon color is standard on all models. Red, white, and blue versions are available at no charge for orders over 24 (per SKU) and will have a lead time of 10–14 days. Color orders must be made in multiples of 6. Color options are also available for orders of 12 or 18 with a \$250 set-up charge.
- The power whip is 12AWG 5 wire.
- Operating Temperature: Full nameplate continuous operation: 0–50° C (32–122° F).
- Vertical Rack Mount.
- Toolless mounting (center spacing): 61.25" (12.25" spacing standard). 59.05" mounting option available on Rack PDU.
- Assembled in the USA with local and off-shore sourced components.
- The product Warranty is 3-year from date of shipment, repair or replace.
- Certification/agency approvals: TUV certified to UL/CSA 60950-1, FCC part 15 class A conformance, RoHS compliant.
- Operating environment: 0–50° C (32–122° F), 5–95% relative humidity, 0–10,000' (0–3000m) elevation.
- Storage environment: -25 –65° C (-13–149° F), 5–95% relative humidity, 0–10,000' (0–3000m) elevation.
- Package dimensions:
84.0" x 22.0" x 5.0" (3 and 4-Pack)
84.0" x 11.0" x 5.0" (1 and 2-Pack)
- The rack PDU weight is 15.0 lbs (1 unit, actual weight varies slightly based on configuration).

Material

- Powder coated heavy steel.

Patent

- Patents pending.

Specifications

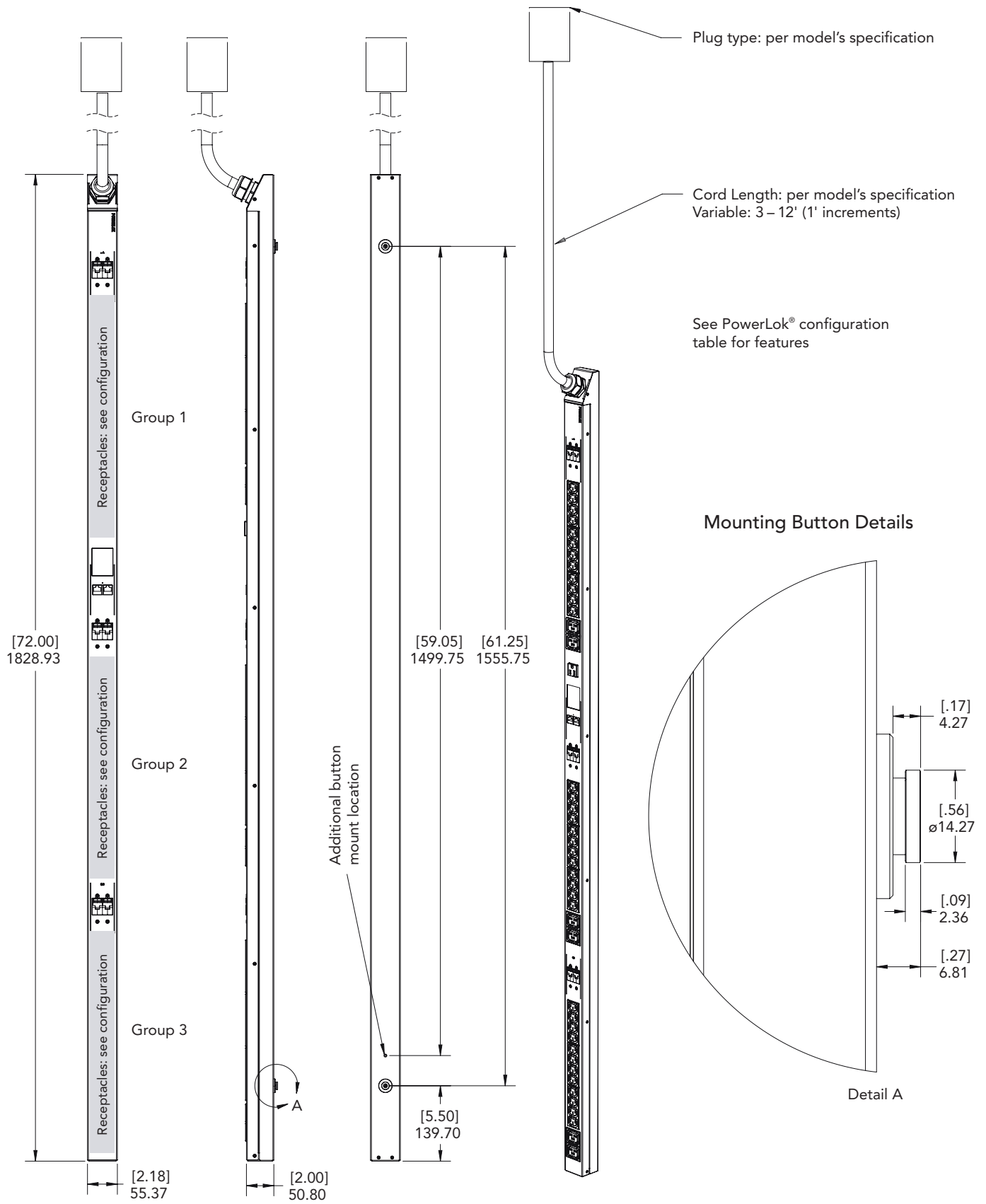

Specifications

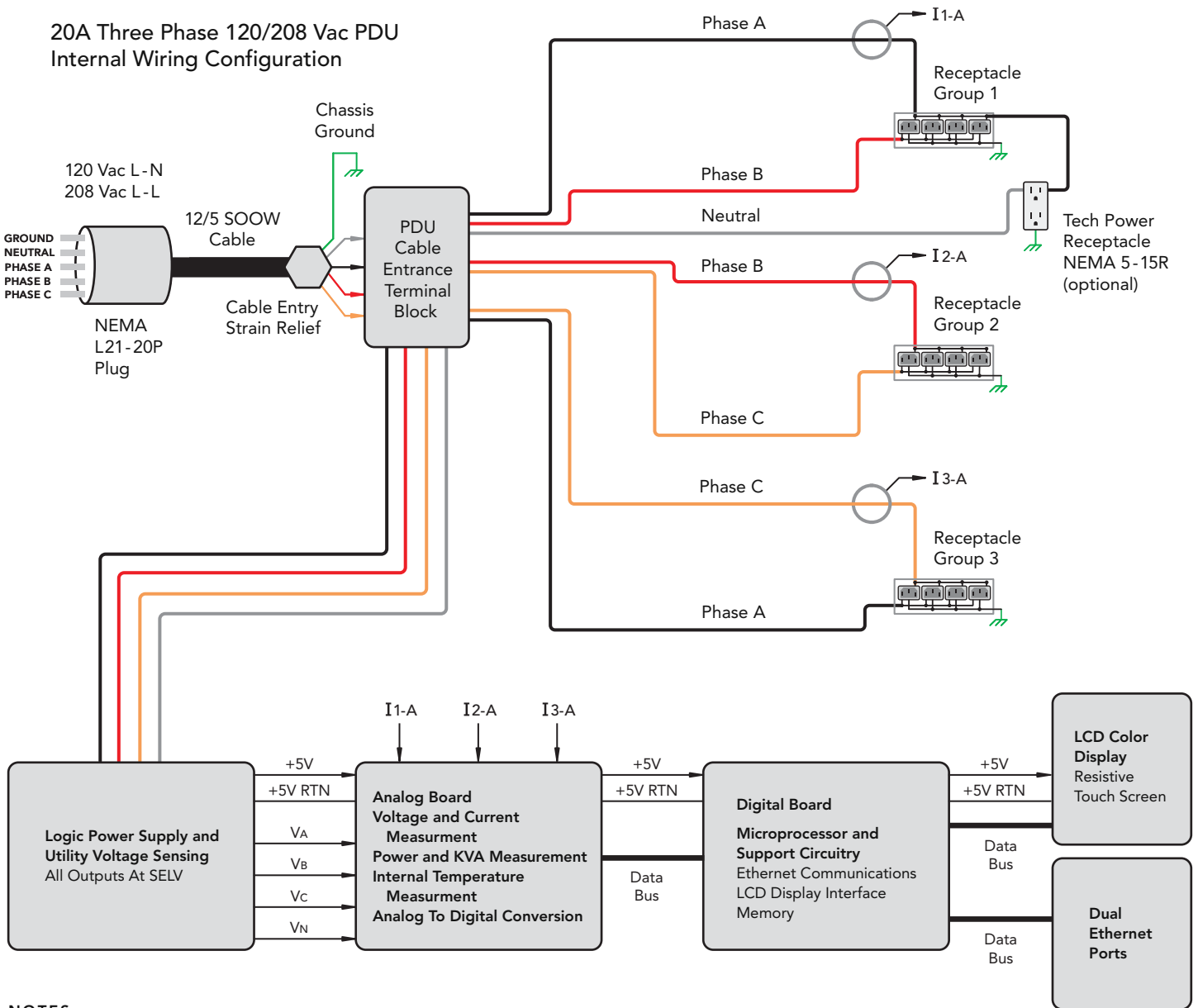

Designer and Manufacturer
 888.982.7800
 www.upsite.com