

W Walker[®]
Edison
furniture company

Item # : OWXB2
Assembly Instructions

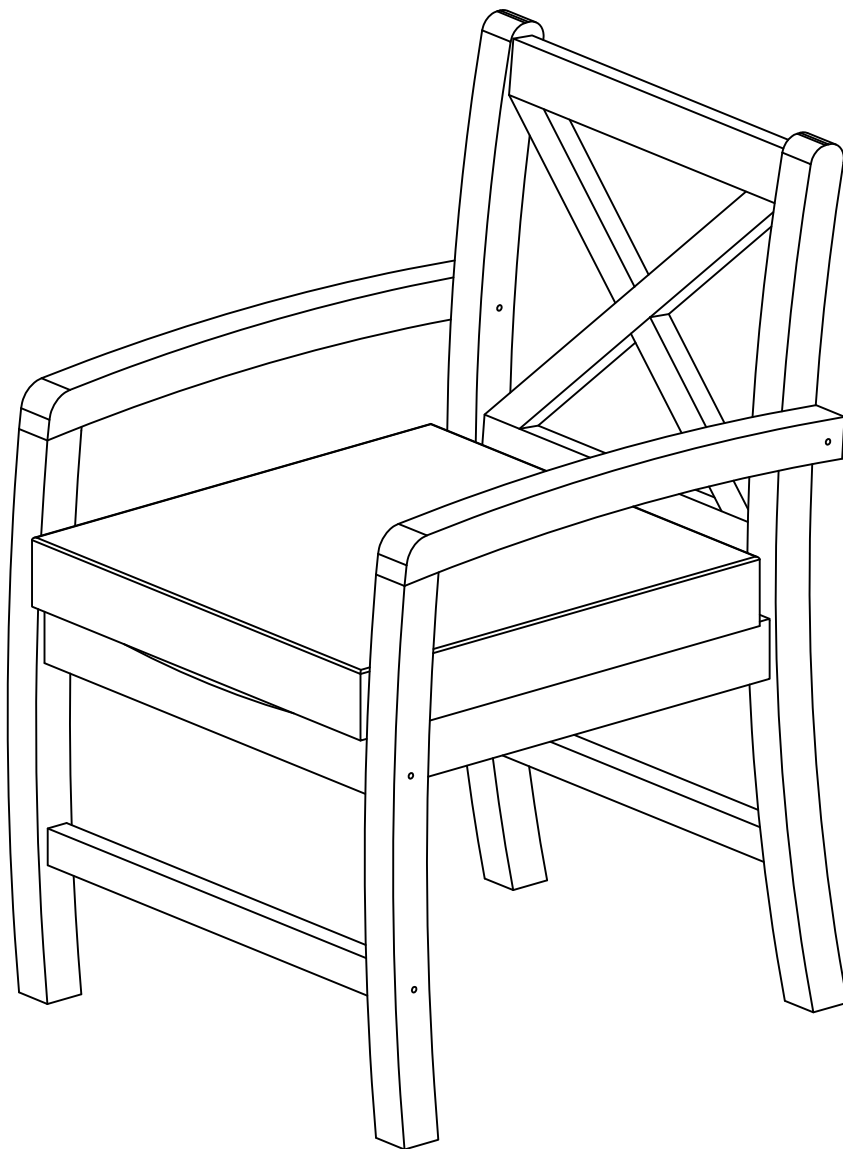



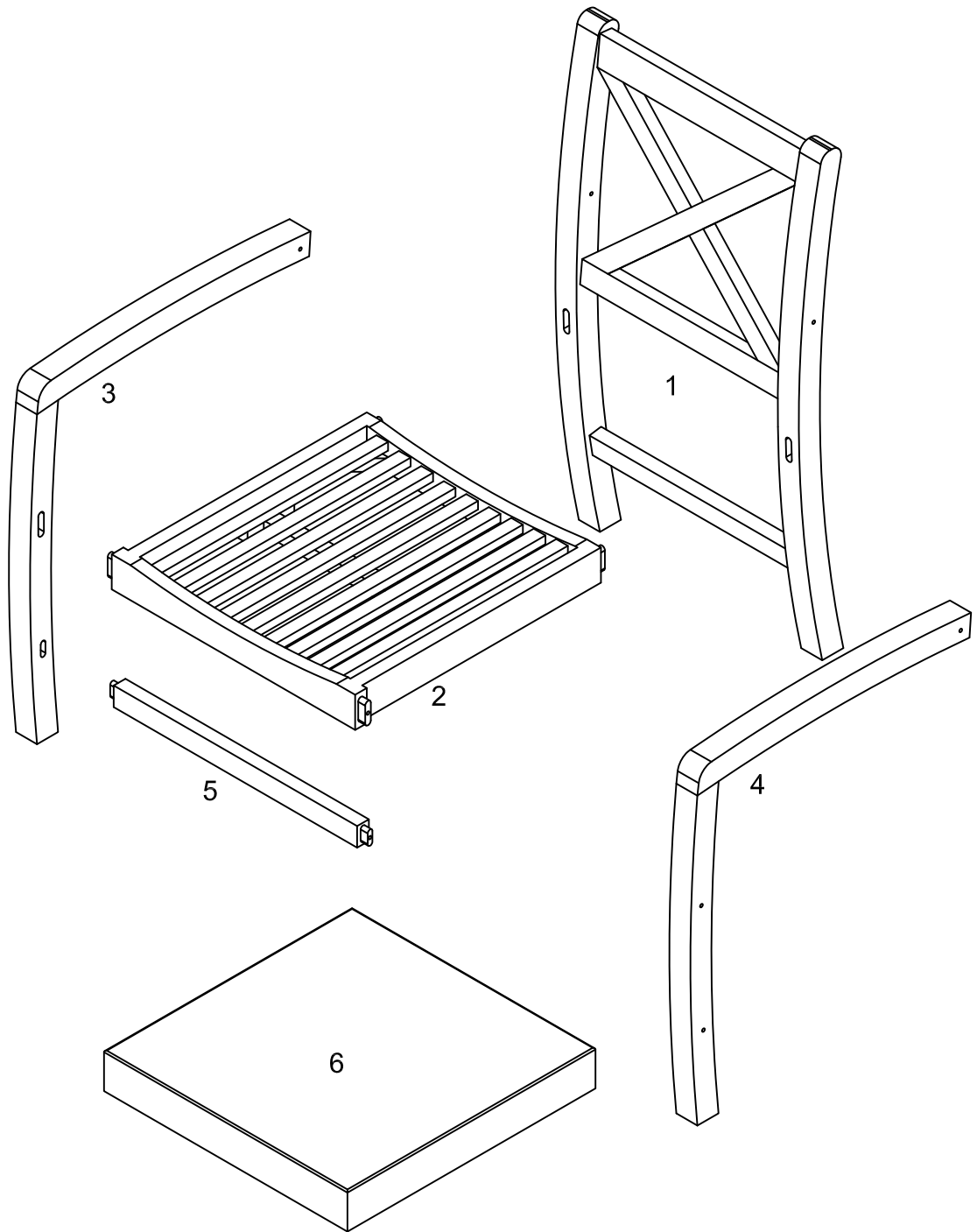

Please visit our website for the most current instructions, assembly tips, report damage, or request parts. www.walker-edison.com

Revised 03/2017

Parts List

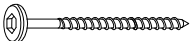

Hardware List

A		M7*90	Screw	12 pcs
B		M8*80	Bolt	4 pcs
C			Nut	4 pcs
D		M4	Wrench	2 pcs

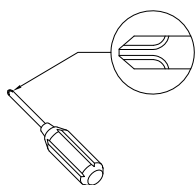

Philips head screwdriver required for assembly
(not included)

*The hardware quantities listed above are required for proper assembly.
Some extra hardware may also have been included.*

Step 1

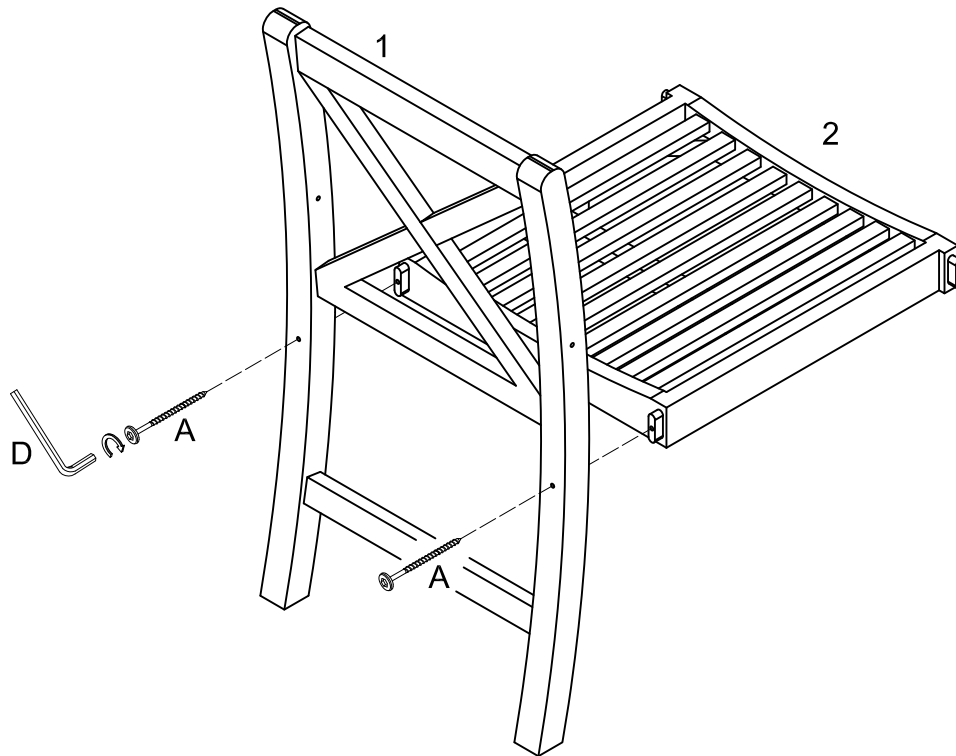

Use Wrench (D), Screw (A) to secure the Back Frame (1) to the Seat Frame (2).

Step 2

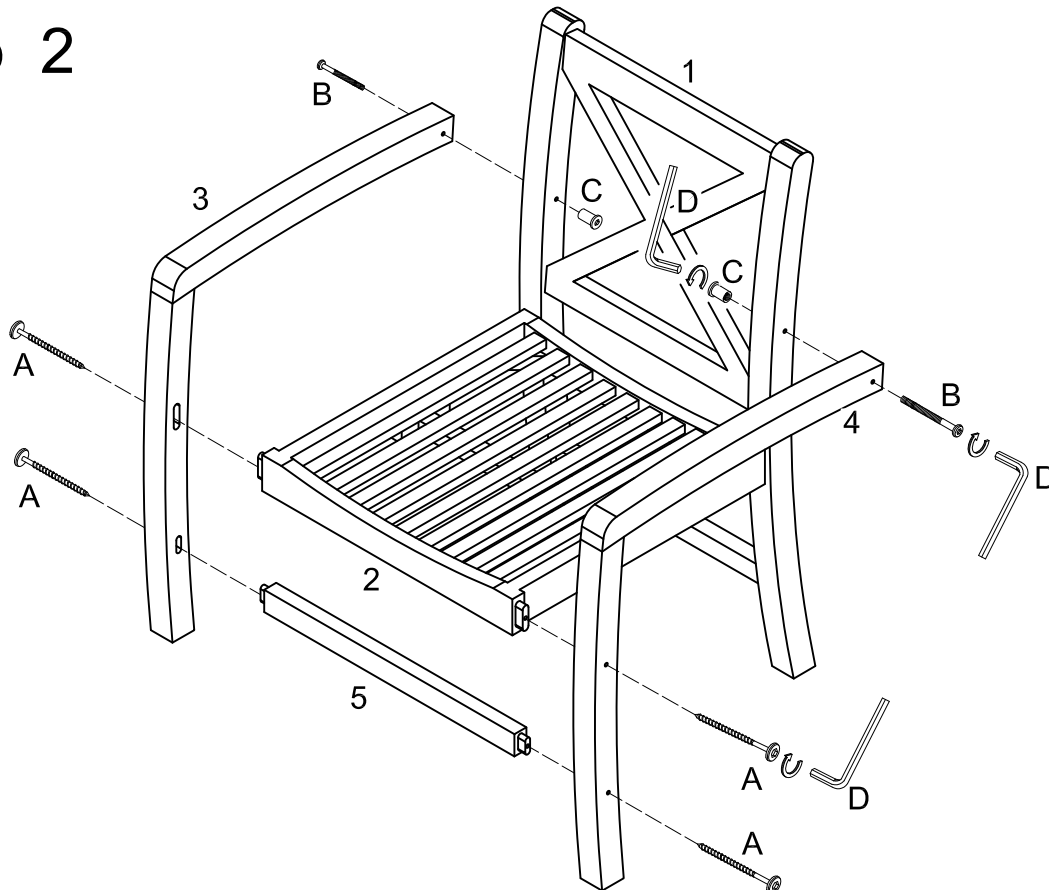

Use Wrench (D), Secure (A), Bolt (B), and Nut (C) to secure the Side Frame (3,4) to the Back Frame (1), Seat Frame (2), and Support Bar (5).

Step 3

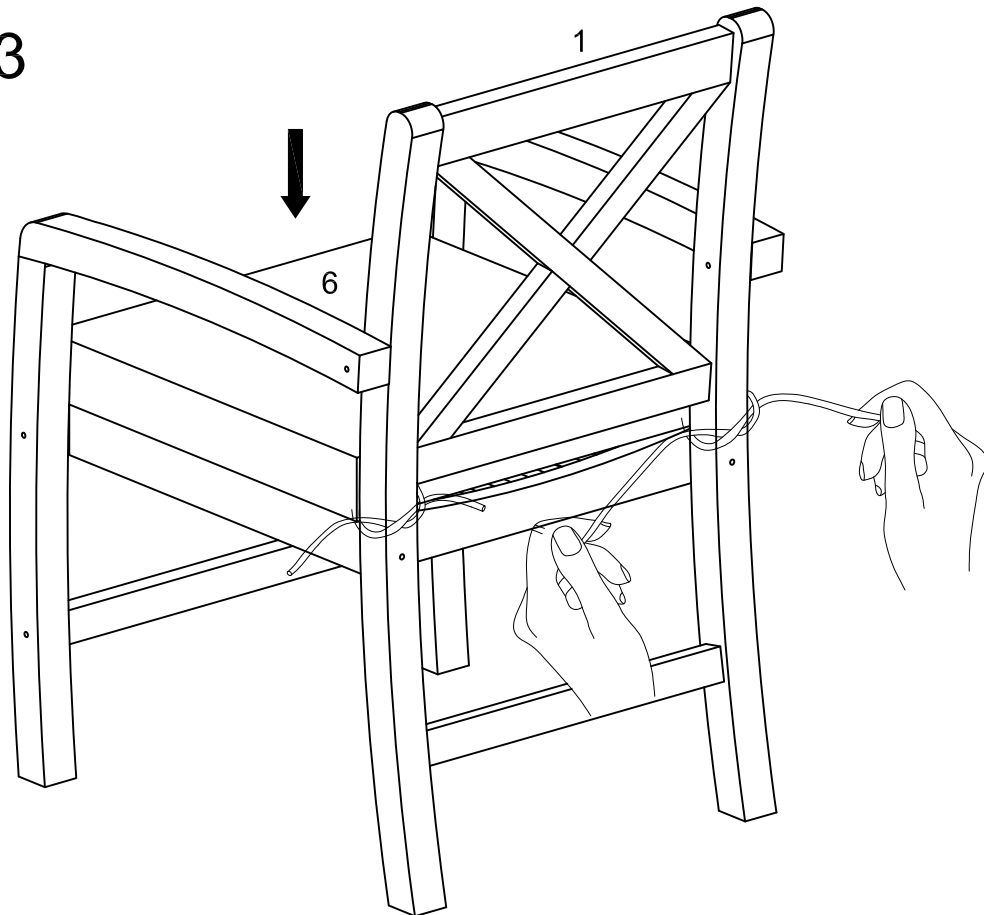

Put the Seat Cushion (6) on top of the Seat Frame (2). And tie the cushion rope to the Back Frame (1) as per diagram.

Step 4

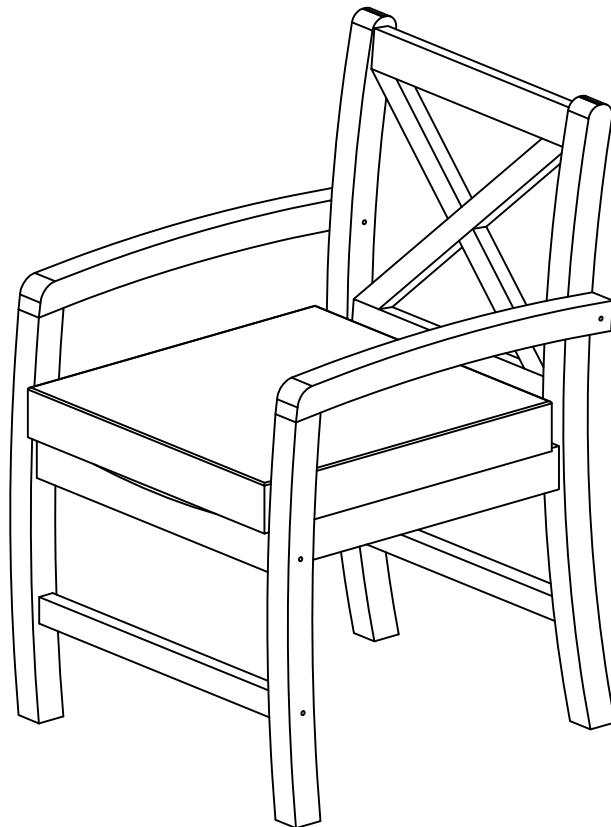

Final Assembly