

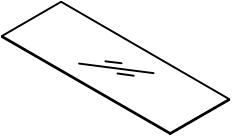

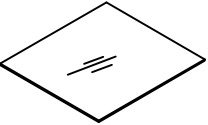

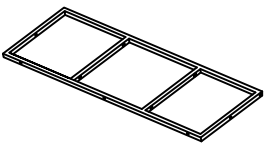

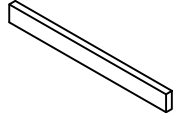

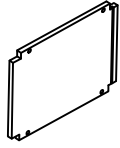
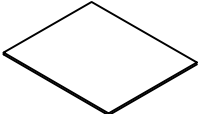
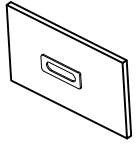
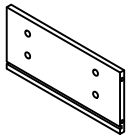
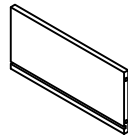
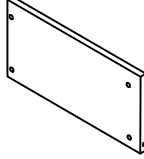
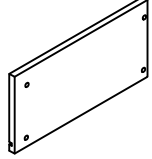
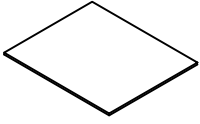

ASSEMBLY INSTRUCTION

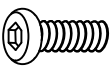
TV STAND

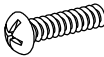
A Top Glass 	B Bottom Glass 	C Metal Frame 	D Front Cross 
E Side Frame - L / R 	F Middle Panel - L / R 	G Back Panel 	H Drawer Panel - Front 
I Drawer Front 	J Drawer Back 	K Drawer Side - Left 	L Drawer Side - Right 
M Drawer Bottom 	N Leg 	O Slide Rail 	P Bolt $\text{Ø}1/4\text{''} \times 28\text{mm}$ 
Q Bolt $\text{Ø}1/4\text{''} \times 70\text{mm}$ 	R Bolt $\text{Ø}1/4\text{''} \times 32\text{mm}$ 	S Bolt $\text{Ø}1/4\text{''} \times 22\text{mm}$ 	T Screw $\text{Ø}5/32\text{''} \times 19\text{mm}$ 
U Screw $\text{M}3 \times 10\text{mm}$ 	V Flat Washer $\text{Ø}1/4\text{''} \times \text{Ø}12 \times 1.5\text{mm}$ 	W Lock Washer $\text{Ø}1/4\text{''} \times \text{Ø}10 \times 1.5\text{mm}$ 	X Allen Key $\text{M}4$ 
12pcs	26pcs	22pcs	1pc

Y Sucking Disc
Ø12x4mm

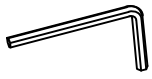

16pcs

Z Screwdriver
(Not Provided)

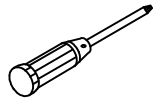

1pc

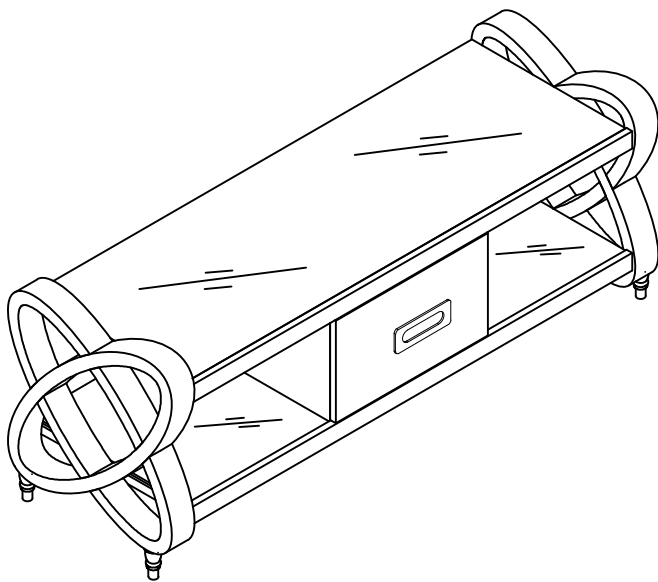

This page lists all the contents included in the box. Please take the time to identify the hardware as well as the individual components to this product. As you unpack and prepare for assembly, place the contents on a carpeted or padded area to protect them from damage.

1 Attach the Drawer Side - Left (K) & Drawer Side - Right (L) to Drawer Front (I), using Screw (T) and tighten with Screwdriver (Z).

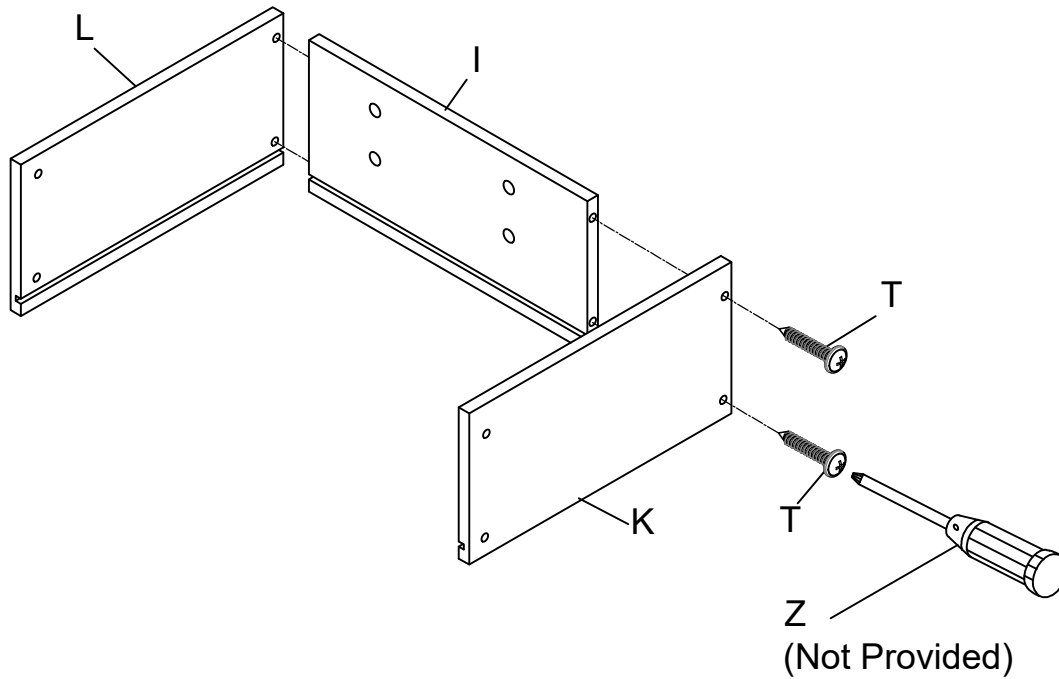
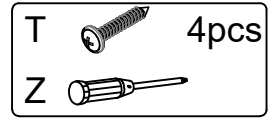

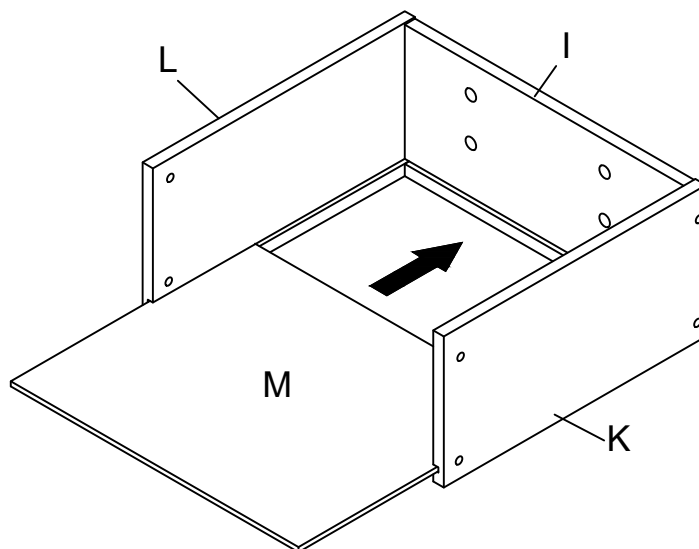

2 Put Drawer Bottom (M) into Drawer Side - Left (K) & Drawer Side - Right (L) and Drawer Front (I).

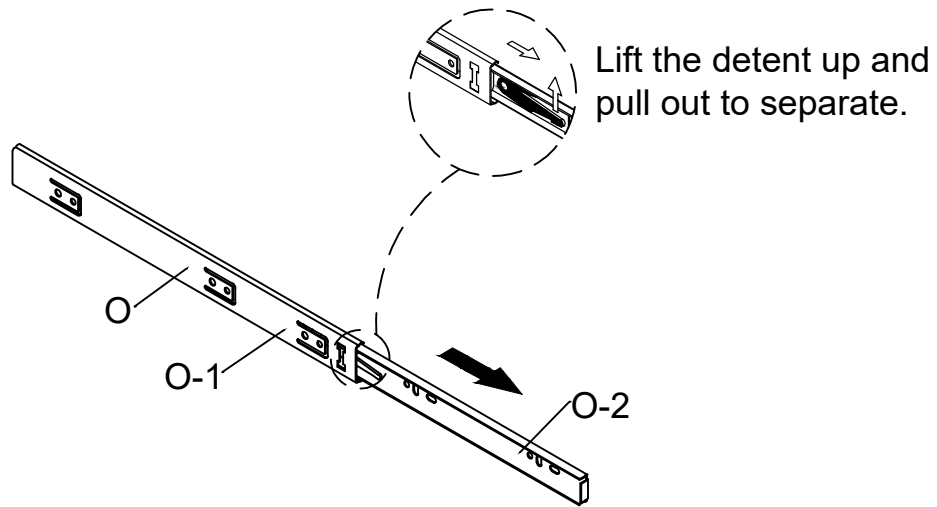

3 Pull out Slide Rail (O) fully extended, a hold-in detent can be seen or touched on slide runners.



4 Attach the Drawer Side - Left (K) & Drawer Side - Right (L) to Drawer Back (J), using Screw (T) and tighten with Screwdriver (Z). Attach the one of Slide Rail (O) to Drawer Side - Left (K) & Drawer Side - Right (L) using Screw (U) and tighten with Screwdriver (Z).

T		4pcs
U		6pcs
Z		

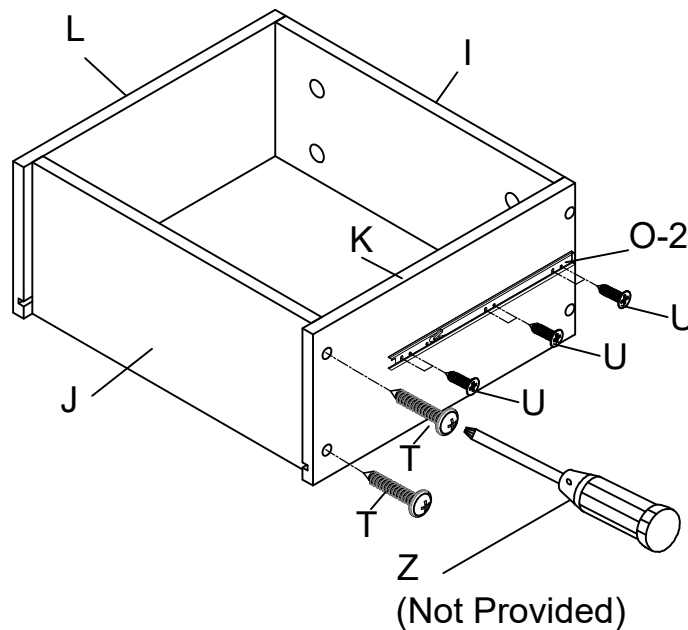

5 Attach the Drawer Front (I) to Drawer Panel - Front (H) using Bolt (S), Flat Washer (V), then tighten with Screwdriver (Z).

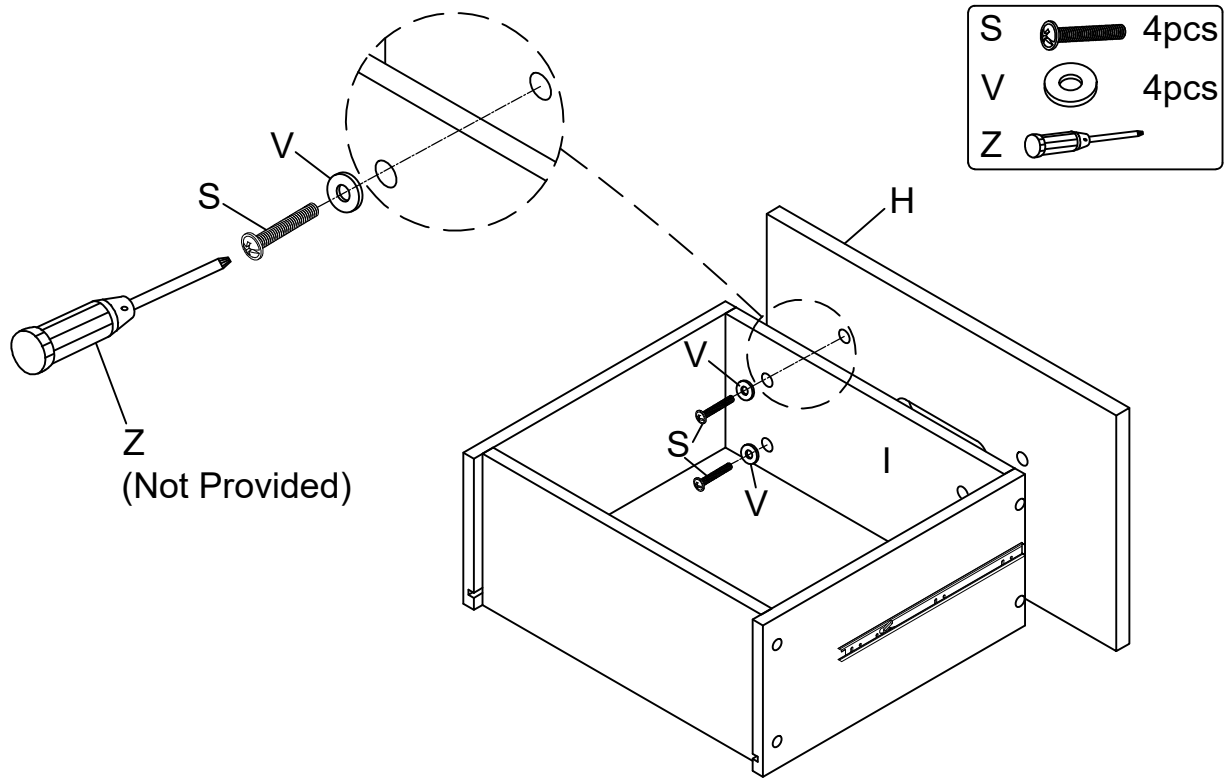

6 Attach the other one of Slide Rail (O) to Middle Panel - L / R (F), using Screw (U) and tighten with Screwdriver (Z).

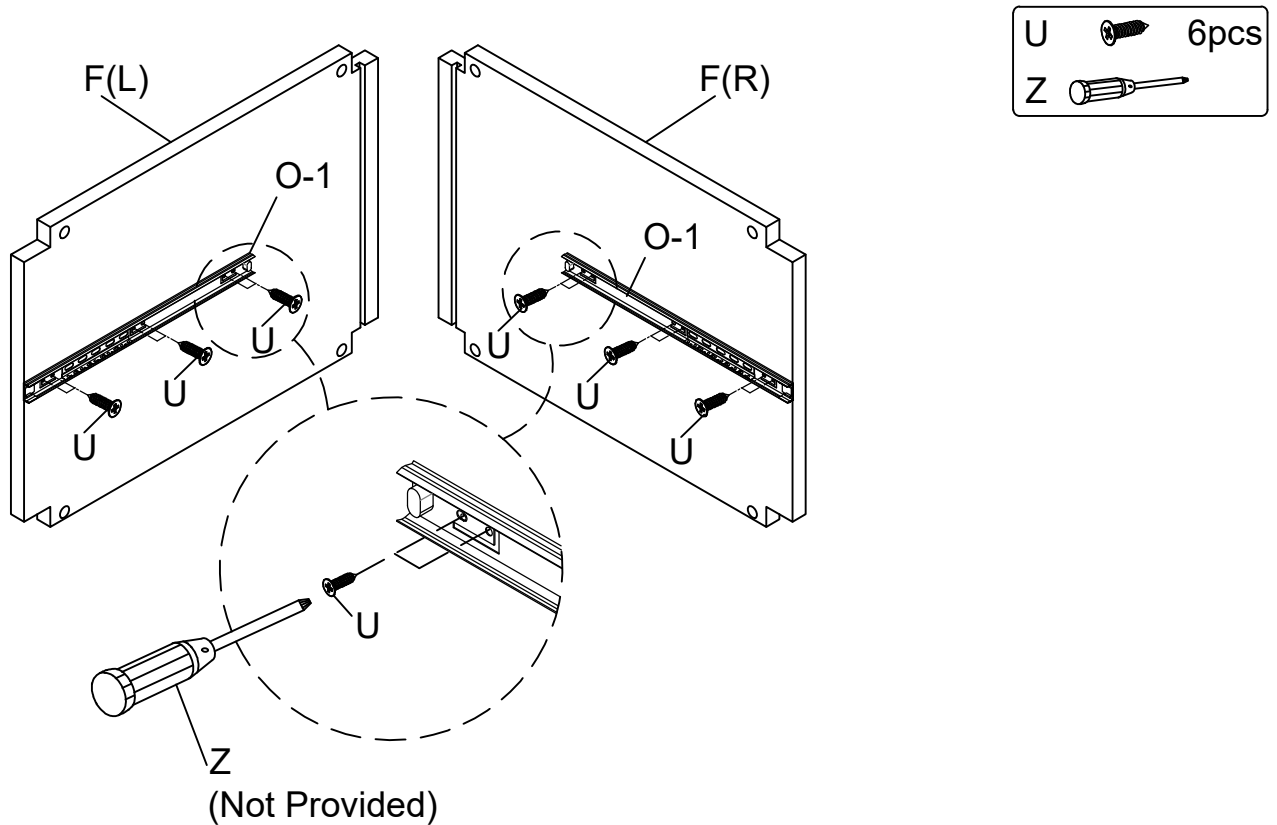

7 Assemble the Leg (M) to the bottom of Side Frame - L / R (E) as below shown.

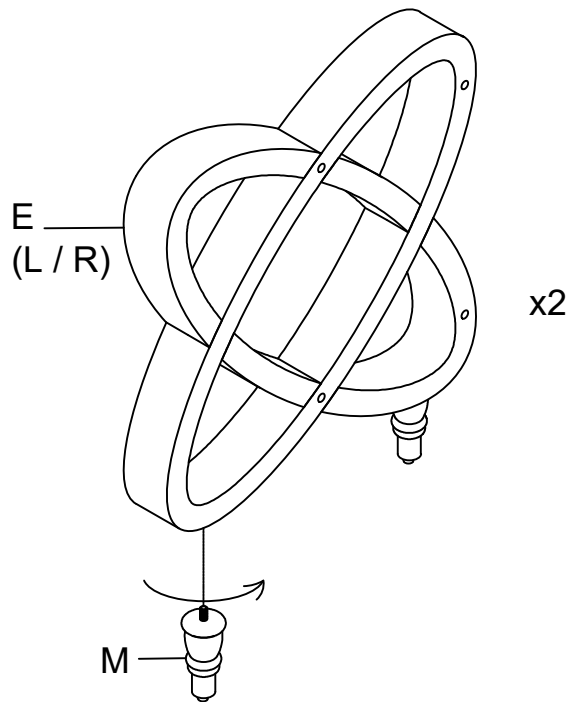

8 Attach the Middle Panel - L / R (F) to one of Metal Frame (C) using Bolt (P), Lock Washer (W) and Flat Washer (V) by Allen Key (X), put Back Panel (G) into Middle Panel - L / R (F) and Metal Frame (C).

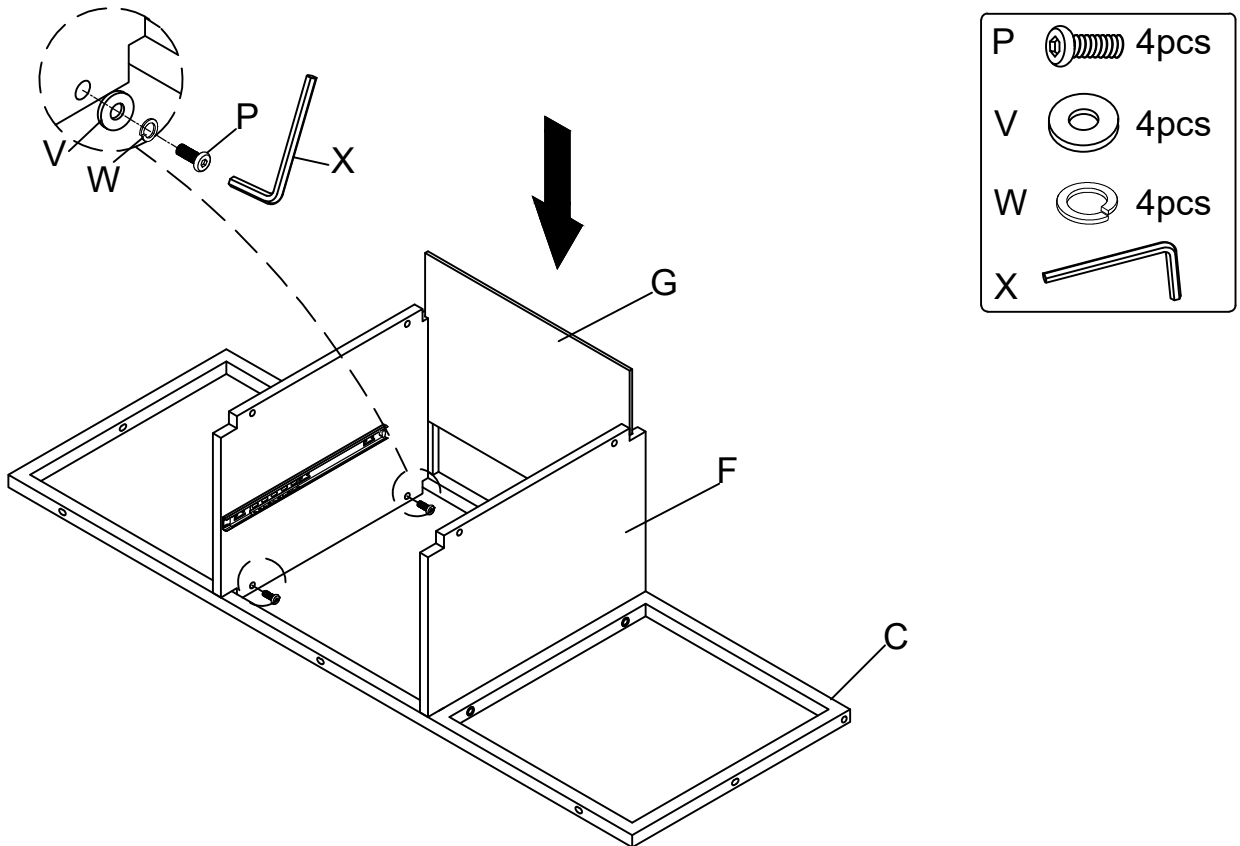

9 Attach the Middle Panel - L / R (F) to the other one Metal Frame (C) using Bolt (P), Lock Washer (W) and Flat Washer (V) by Allen Key (X), attach the Front Cross (D) to Metal Frame (C) using Bolt (P), Lock Washer (W) & Flat Washer (V) by Allen Key (X).

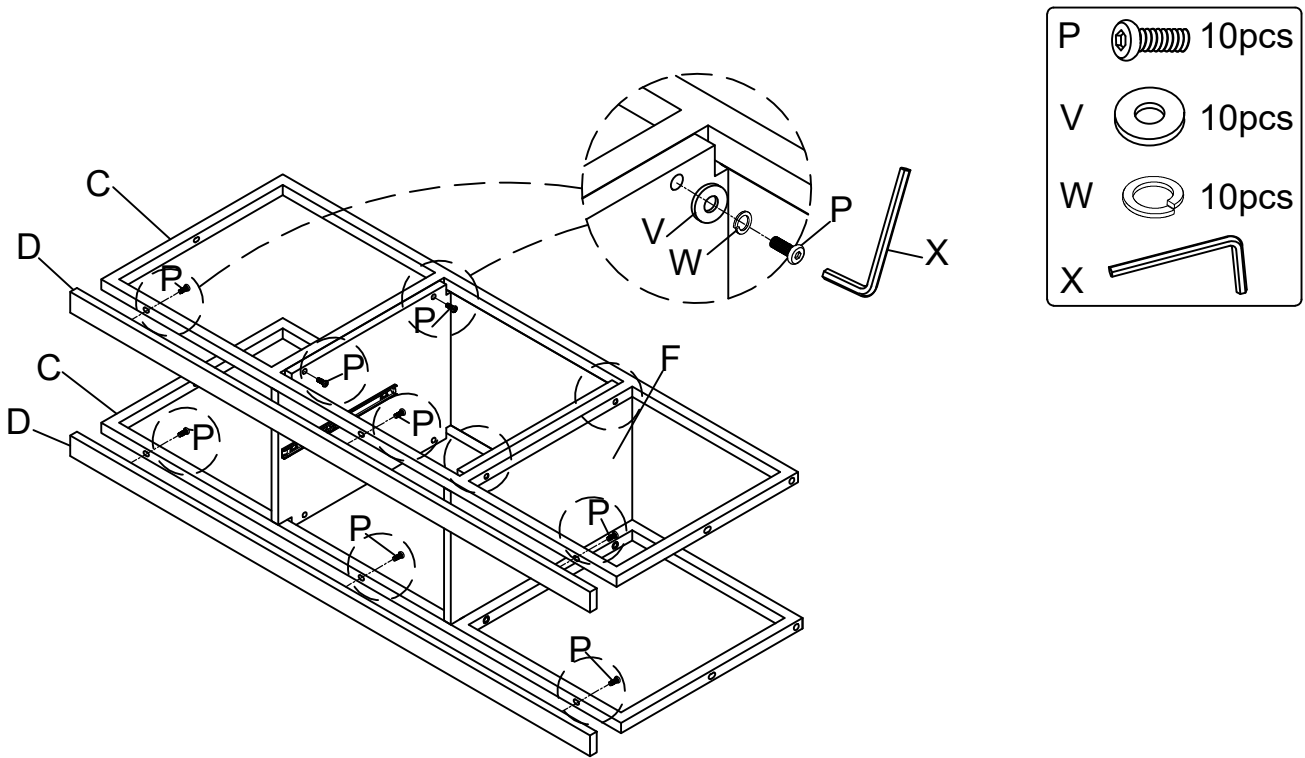

10 Attach the Metal Frame (C) to Side Frame (E) using Bolt (Q) & Bolt (R), Lock Washer (W), and Flat Washer (V) by Allen Key (X).

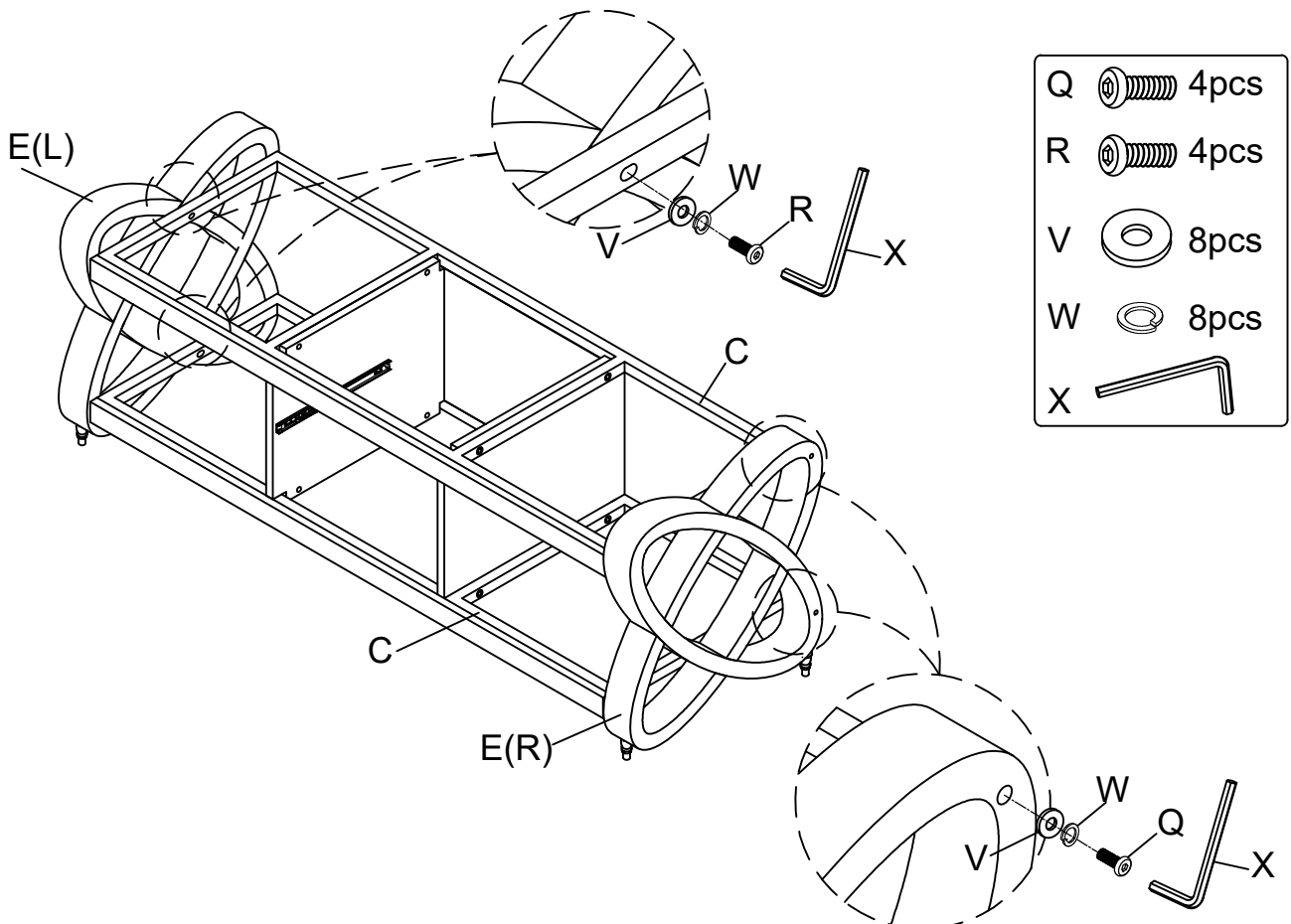

11 Put the Sucking Disc (Y) to Metal Frame (C), then put Top Glass (A) & Bottom Glass (B) onto Metal Frame (C) with Sucking Disc (Y).

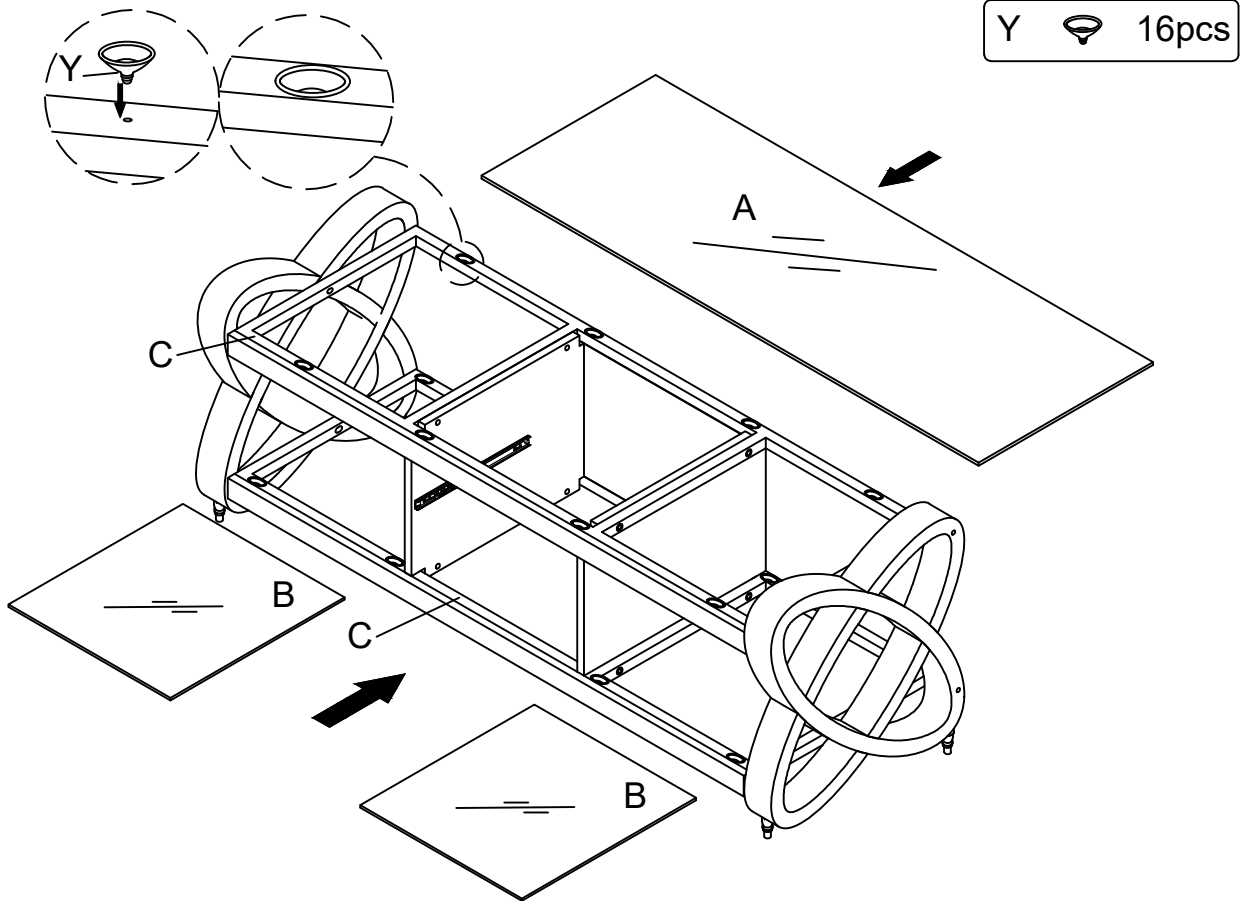

12 Attach the assembled drawer to Middle Panel - L / R (F) by using Slide Rail (O). Move slide ball spacers to front. Hold drawer horizontally, and slide runners into ball spacers.

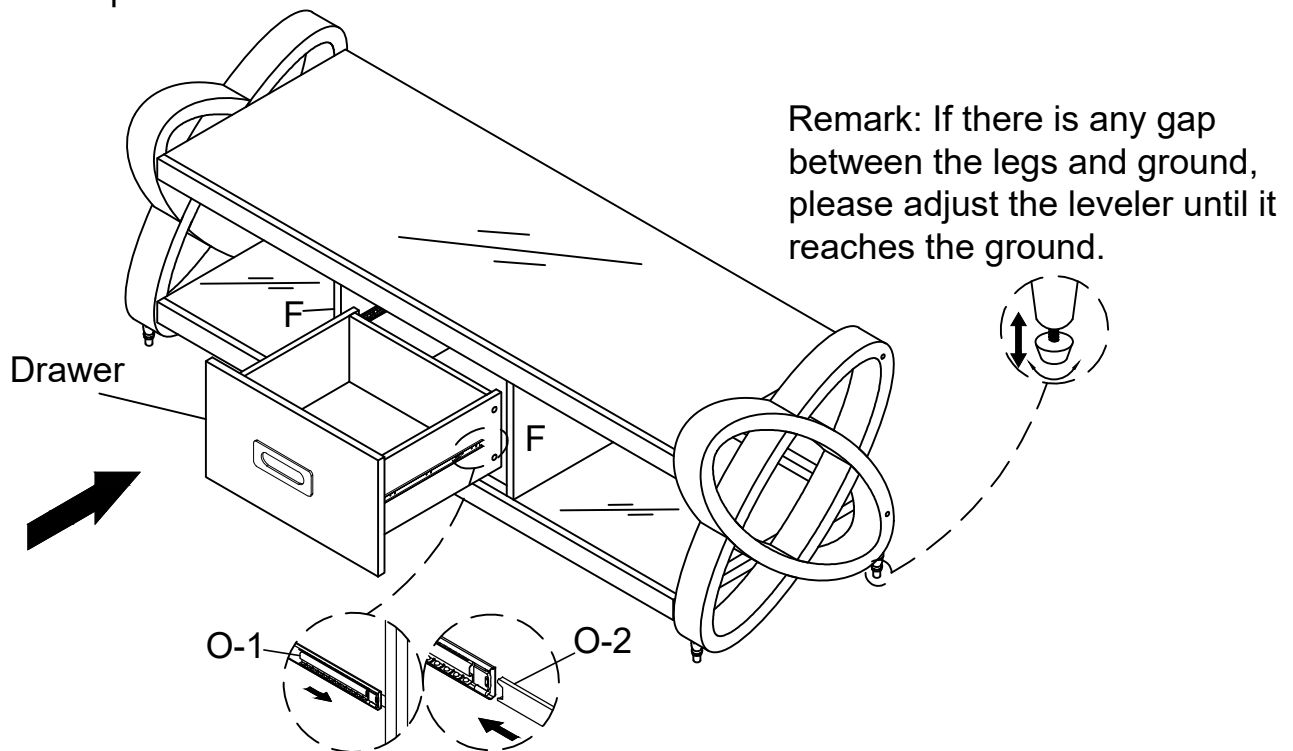

Cleaning & Care

Treat surface with care. Surface is resistant to scratches but is not scratch resistant. Clean surfaces with a dry or damp soft cloth. Do not use abrasive cleaners. Hardware may loosen over time. Periodically check that all connections are tight.