

# Backflow Preventers

## Double Check Valve Assembly 950XL Series

Applications

With its time tested design, the Wilkins 950XL is capable of handling the toughest backflow conditions that any double check valve assembly may incur. The 950XL, with its “wye” pattern configuration, offers individual access covers to each check valve, replaceable check seats, and silicone seal rings, all wrapped in a bronze body for use in non-health hazard applications. Since the 950XL carries the Wilkins name, you can rest assured that the 950XL will provide “Performance Under Pressure”.



Features

- 3/4", 1", 1 1/4", 1 1/2", 2"
- Double check valve assembly consisting of two independently operated spring-loaded center guided check valves, wye pattern body
- Complete with two full port resilient seated ball valves for shut-off and four resilient seated ball valve test cocks
- Bronze body construction
- Noryl® replaceable seats and silicone rubber check discs
- Entire unit serviceable in line
- Temperature range 33°F – 180°F
- Maximum pressure 175 psi
- With BSP threaded connections
- Available with stainless steel handles (optional)
- ASSE® Listed 1015, IAPMO® Listed, C-UL® Classified (Model 950LXL), UL® Classified (Model 950LXL), CSA® Certified, AWWA
- Approved by the Foundation for Cross-Connection Control and Hydraulic Research at the University of Southern California

Options

- Model 950XL** FNPT x FNPT end connections
- Model 950LXL** Less shut-off valves – male pipe thread
- Model 950XLS** Supplied with wye strainer
- Model 950LTCU** With test cocks up
- Model 950XLU** Supplied with union connections between ball valves and the device
- Model 950XLU S** Same as 950XLU except supplied with wye strainer
- Model 950XLOS Y** With OS&Y gate valves. UL® Classified only
- Model 950XLFDC** Same as 2" size 950XL except supplied with 2 1/2" female swivel inlet hose connection and 2 1/2" male outlet hose connection, for temporary water service from fire hydrant
- Model 950XLFT** Supplied with fast-test test cocks
- Model 950XL SH** Supplied with stainless steel handles

For Additional Information, reference WK-BPC catalog or visit our web site.

Accessories

- Thermal expansion tank (Model XT)
- Quick test set (QT-SET)
- Test cock lock (Model TCL24)
- Ball valve monitor switch (Model BVMS)

Local codes shall govern installation requirements. To be installed in accordance with the manufacturer's instructions and the latest edition of the Uniform Plumbing Code. Unless otherwise specified, the assembly shall be mounted at a minimum of 12" (305mm) and a maximum of 30" (762mm) above adequate drains with sufficient side clearance for testing and maintenance. The installation shall be made so that no part of the unit can be submerged.

Typical Installation

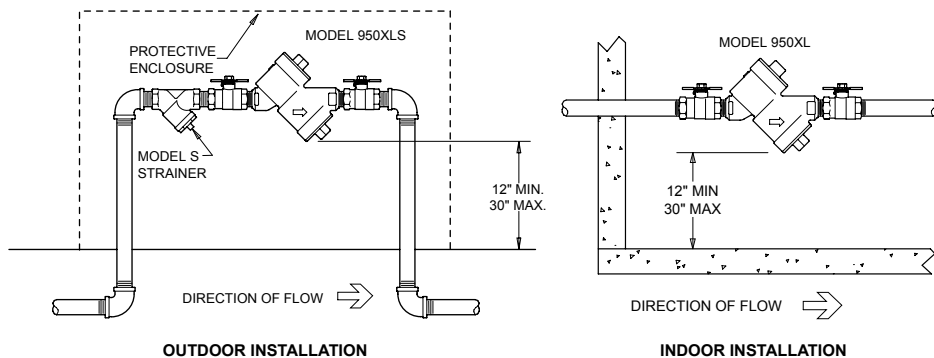

X Ref

WILKINS	WATTS	CONBRACO	FEBCO	AMES	HERSEY
950XL	007QT, 775, 719	40-100-T2	805Y, 850	200B, 2000B,	HDC, FDC
950LXL	007LF	40-100-T1			
950XLS	007QTS				
950LXTCU					
950XLU	U007QT	40-100-T4			
950XLUS	U007QTS				