

Hopping Frog

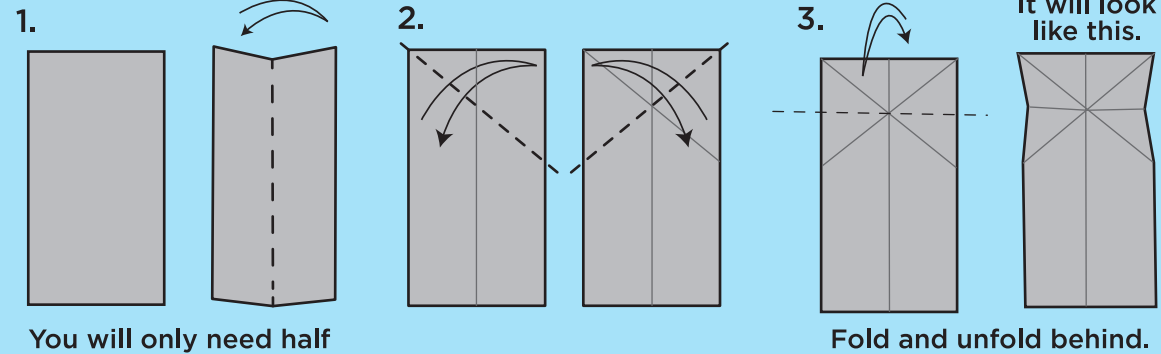

You will only need half a piece of paper.

Fold and unfold behind.

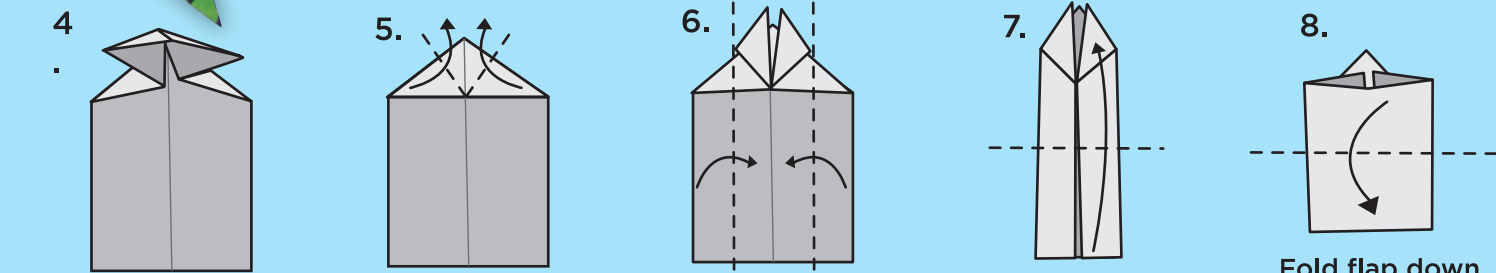

Squash the top of the paper down onto itself. The sides will naturally fold in.

Fold to center

Fold flap down.

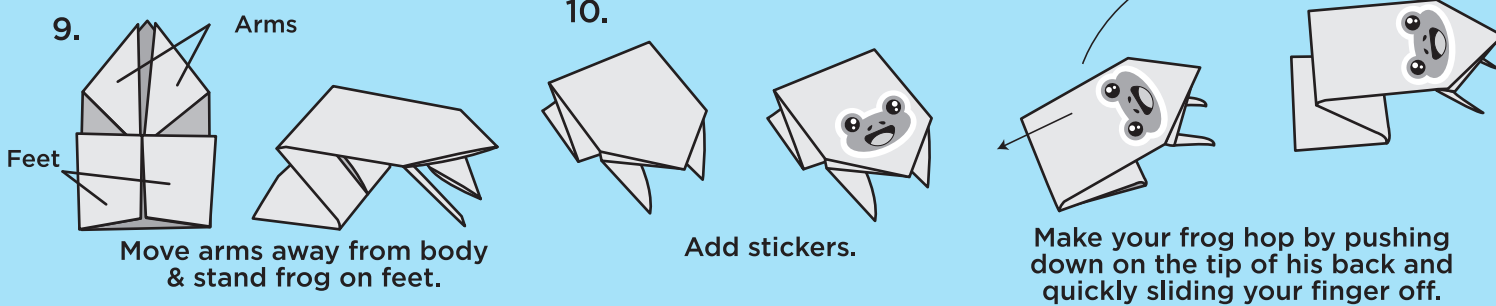

Move arms away from body & stand frog on feet.

Add stickers.

Make your frog hop by pushing down on the tip of his back and quickly sliding your finger off.

NEON ORIGAMI

Age 7+

Learn the ancient art of paper folding to create a Bunny, Frog, Tiger, Star, and Crane. Use the stickers included to add more fun to your finished folds.

25 SHEETS OF SUPER BRIGHT PAPER



Origami is a craft that requires patience. If you need extra help, you can visit our YouTube channel at youtube.com/justaddimagination. There you will find a step-by-step video to guide you. Remember, you can start and stop the video as needed. Be sure to ask for adult permission and assistance before visiting our website.

Use these symbols to help understand the diagrams in the instructions:

Flip Over

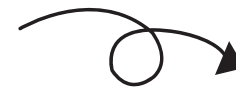

Fold



Fold/Unfold



- Find a clean smooth surface to work on.
- Follow the instructions and pictures carefully.
- For best results, line up your paper exactly and make crisp folds.
- Start with the pattern side facing the table.



Remember, if you are having trouble with any of the origami steps, refer to the on-line video for extra help. youtube.com/justaddimagination



Bunny

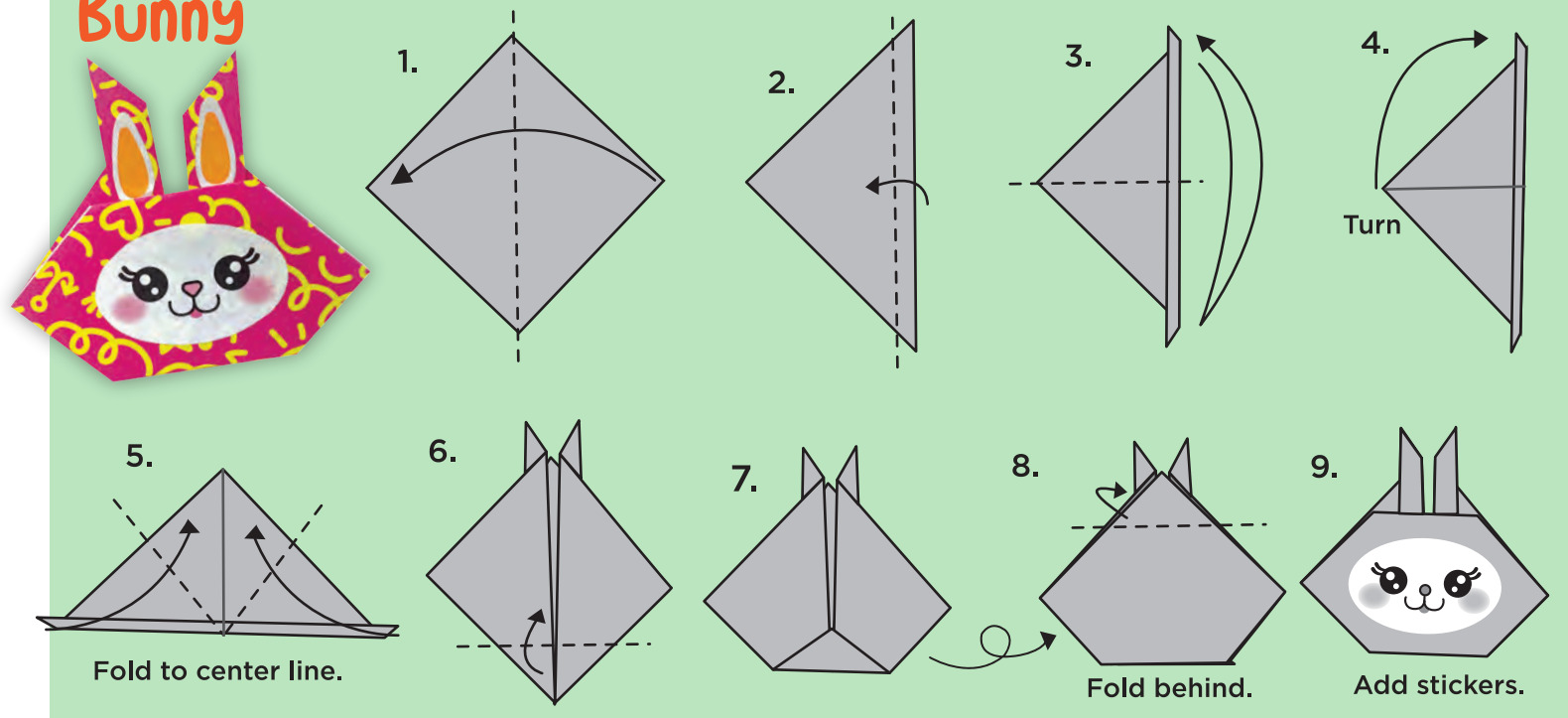

Fold to center line.

Fold behind.

Add stickers.

Neon Origami #6503000
© Faber-Castell USA, Inc. • Cleveland, Ohio 44131 • www.fabercastell.com
Designed in USA • Made in China

Need Help?
Call: 800-311-8684 e-mail: consumer@fabercastell.com
Chat or view FAQs & INFO online:

www.CreativityforKids.com



Crane

1. Fold and unfold to crease.
2. Fold and unfold to crease.
3. Fold and unfold to crease.
4. Fold and unfold to crease.
5. Fold along the diagonal. Then push the bottom left corner up and in so it folds in between and meets the top corners.
6. Repeat step 5 on the other side.
7. Fold and unfold the two front flaps and the bottom corner to crease.
8. Turn and repeat step seven on the other side. It should look like this.
9. Pull down front flap creating a smooth fold.
10. Turn over & repeat step 9.
11. Rotate 180
12. Fold & unfold to crease.
13. Make a reverse fold by opening the right flap, placing your index finger on the crease inside the flap then pushing up with your thumb as you invert the fold.
14. Repeat the reverse fold on the other side.
15. Fold and unfold to crease.
16. Push down and in on the center fold inverting it along the creased folds.
17. Pull each part of the bottom out to make your crane fly.

Tiger



- 1.
- 2.
- 3.
- 4.
- 5.
- 6.
- 7.
- 8.
- 9.
- 10.
- 11.
- 12.

Fold top layer down. Fold bottom layer behind. Add stickers.

Star

Use square paper

1. Fold paper in half and tear along the fold to create two sheets.
2. Fold each piece in half.
3. Fold in opposite corners as shown.
4. Fold in the dotted diagonal lines.
5. Fold in opposite diagonal lines.
6. Flip over one of the shapes.
7. Rotate the shape you flipped and place the other on top of it as shown.
- 8.
- 9.
10. Your ninja star is now complete!

Fold in edges of bottom shape. Tuck them into pocket created by top shape. Repeat on second shape, tucking into pocket. Flip over and repeat with untucked shape.