









HEKMAN

ASSEMBLY INSTRUCTIONS

23523 - UPH SIDE CHAIR

⊕ A HOWARD MILLER COMPANY

A		13mm	1Pc
B		5/16" x 12.5 x 8.5mm	4Pcs
C		5/16"	9Pcs
D		5/16" x 19mm	9Pcs
E		5/16" x 38mm	1Pcs
F		5/16" x 70mm	4Pcs
G		♂8 x 38mm	4Pcs
H		5mm	1Pc

Step 1

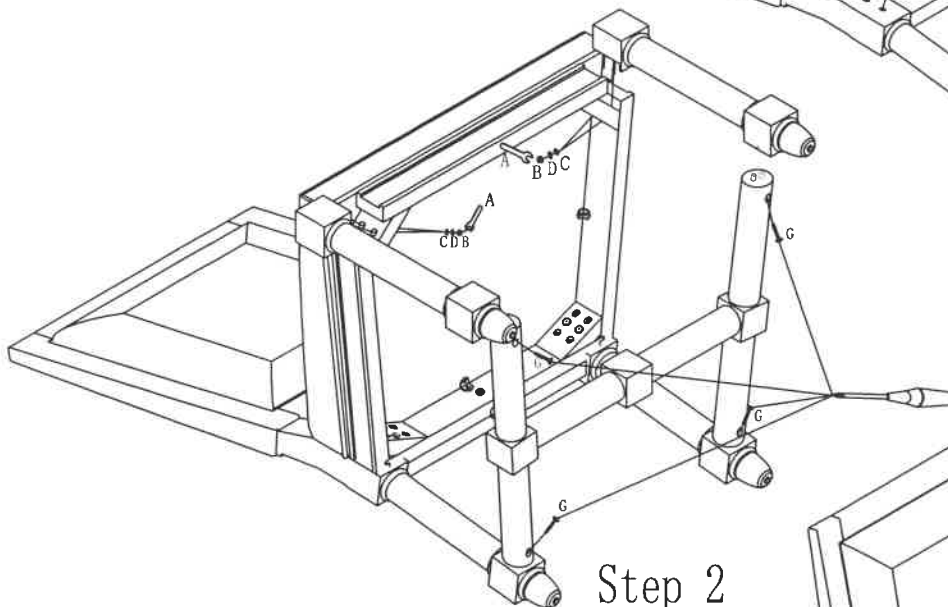
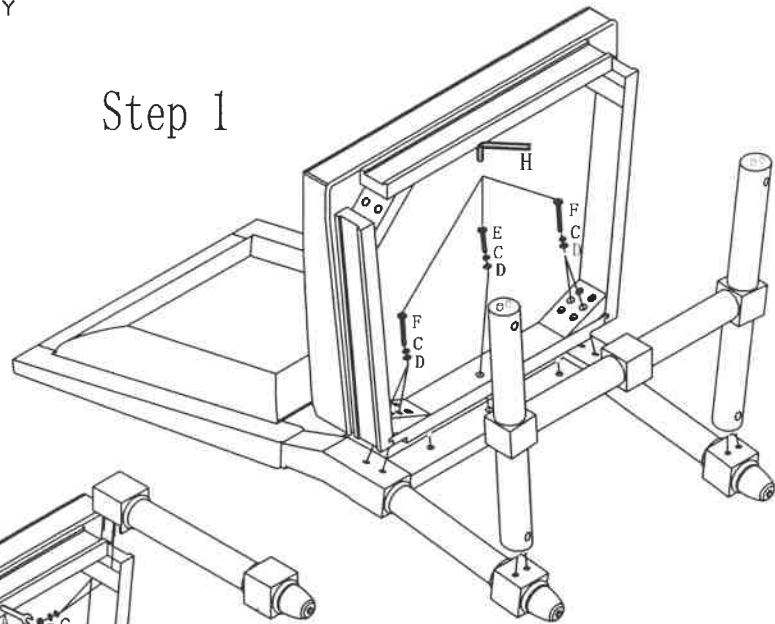

Step 2

Assemble the chair on soft and clean surface to prevent scratching. Loosen screws holding upholstered seat to seat apron assembly, it's not necessary to remove the seat completely.

Step 1: Assemble the back frame and the chair seat together with Bolt (E, F), Spring Washer (C) and Flat washer (D) using Wrench (H).

- Assemble the stretcher to the back legs.

Step 2: Assemble the front legs to the chair with Hex Nut (B), Spring Washer (C) and Flat washer (D) using Wrench (A). Do Not tighten the screws or nuts completely.

Step 3: Set the chair upright on a flat surface. Adjust the front legs so all four chair legs touch the floor, tighten nuts completely on the front legs. The seat cushion may need to be loosen to adjust the front legs.

Step 4 - tighten screws holding seat cushion to apron assembly.

- Attach the stretcher to the front and back legs with Screw (G).

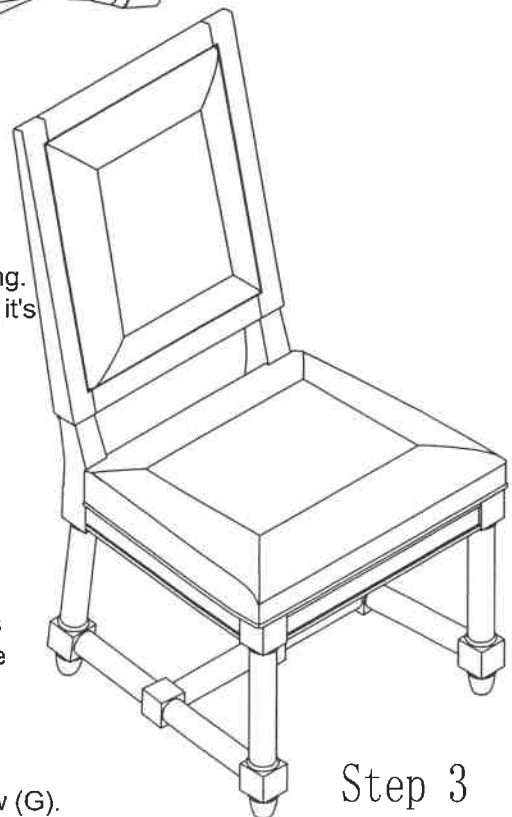

Step 3

MADE IN CHINA