









HEKMAN

X A HOWARD MILLER COMPANY

ASSEMBLY INSTRUCTIONS

25229 / 25429 - RECTANGLE DINING TABLE

NO.	Hardware List		Q'ty
A		Bolt 5/16" * 150mm L	4
B		Lock Washer 5/16"	4
C		Flat Washer 5/16"	4
D		Wrench L 5	1
E		Bolt m6 * 80mm L	18
F		Lock Washer m6	18
G		Flat Washer m6	18
H		Wrench L 4	1

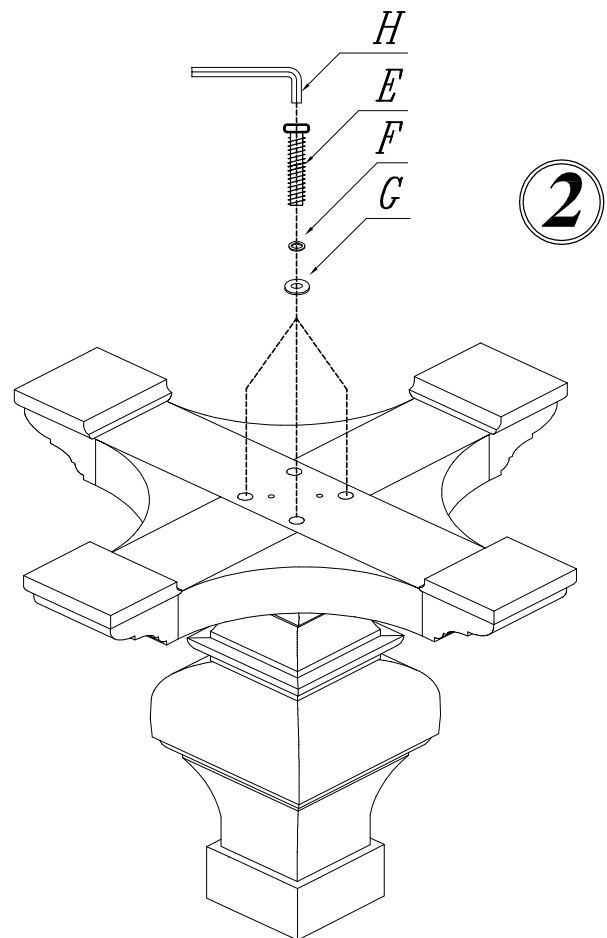
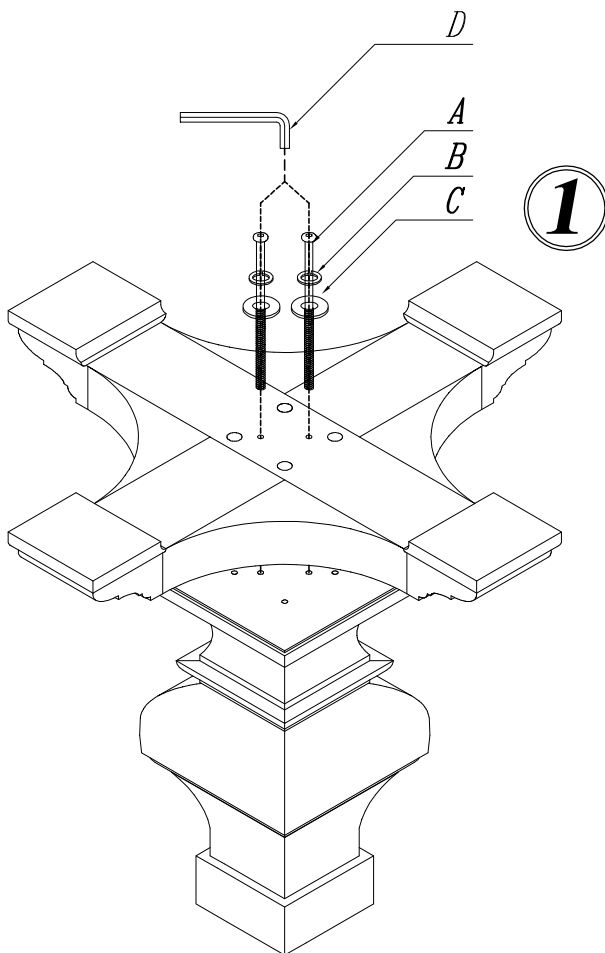

1. Put column upside down, use Bolt (A) lock washer (B) flat washer (C) to secure the base to the column using Wrench (D)
2. Use Bolt (E) lock washer (F) flat washer (G) and tighten the bolt using wrench (H)

MADE IN INDONESIA

HEKMAN

A HOWARD MILLER COMPANY

ASSEMBLY INSTRUCTIONS

25229 / 25429 - RECTANGLE DINING TABLE

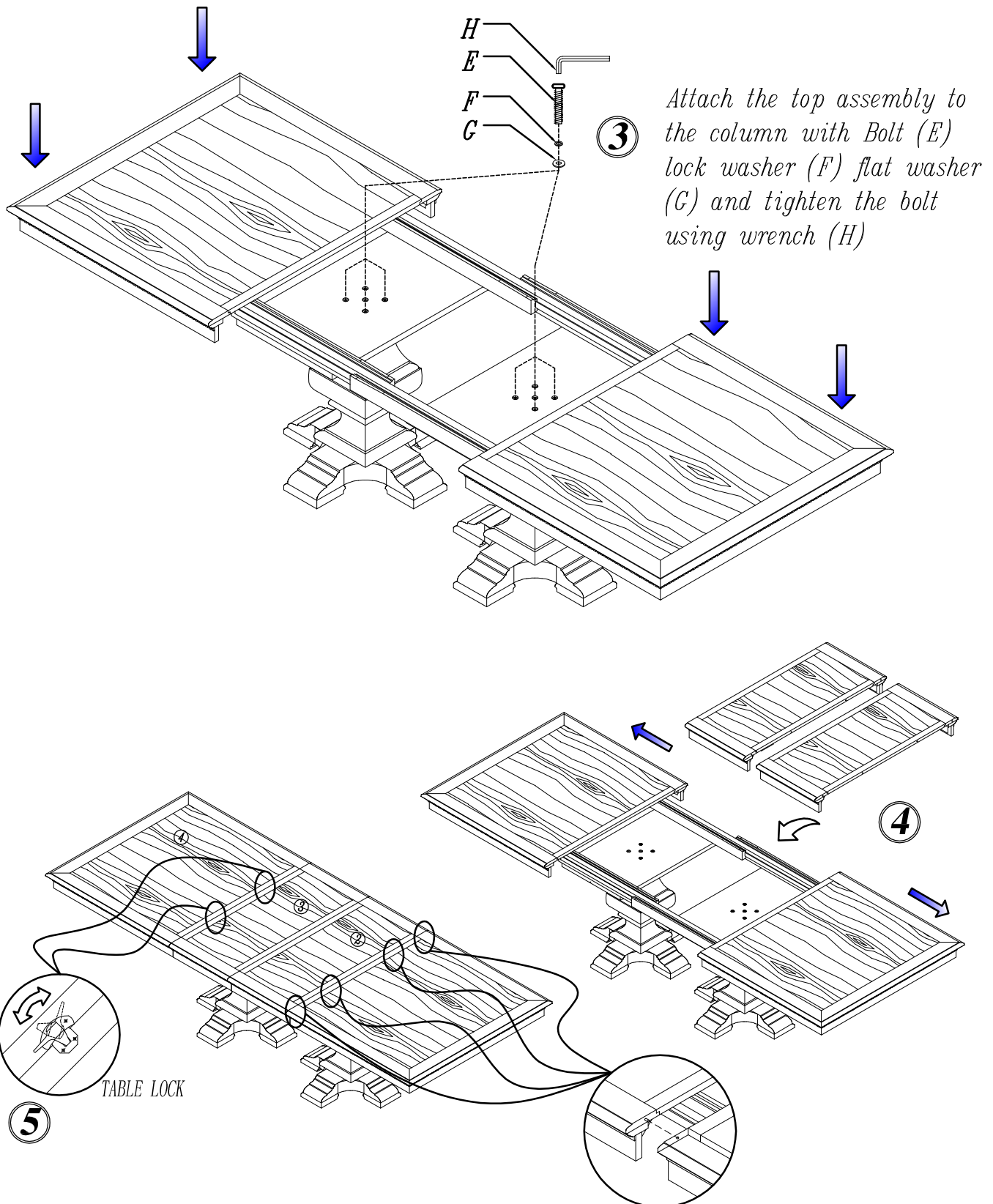

4. Install extension leaf in the center, align brass pins so they can connect and secure
5. Secure the leaf extension using table lock under the table

*NEED 2 PERSON TO OPEN AND CLOSE THIS TABLE

MADE IN INDONESIA