

# BLACK DIAMOND®

Project Name: \_\_\_\_\_

Location: \_\_\_\_\_

Item #: \_\_\_\_\_

Qty: \_\_\_\_\_

## Black Diamond Chest Freezer, Two Solid Doors, 15.4 Cu. Ft., in White

### BDCF-16/2R



The Black Diamond Chest Freezer offers reliable frozen storage for commercial use, perfect for restaurants, cafes, and catering businesses. Featuring a solid steel door and embossed aluminum tub, it ensures durability and easy cleaning. With a generous 15.4 cubic feet capacity, it accommodates bulk food storage needs. Maintains temperatures from -4° to 3.2°F, with side-mounted compressor for efficiency. Mechanical controls and manual defrost enhance usability, making maintenance straightforward.

### FEATURES AND CONSTRUCTION

- Offers a generous 15.4 Cu. Ft. capacity for ample frozen storage
- Features a 1/8 horsepower side-mounted compressor for efficient cooling
- Constructed with a white powder-coated steel exterior and embossed aluminum interior
- Maintains a temperature range of -4° to 3.2°F for optimal food preservation
- Utilizes eco-friendly R290 refrigerant for efficient cooling performance
- Operates on 115V with a NEMA-5-15P plug for convenient power access
- Built-in casters provide easy mobility for cleaning and repositioning
- Hinged lids open 90° for easy access to stored items
- Mechanical controls offer user-friendly temperature adjustments
- Foamed-in-place polyurethane insulation ensures consistent temperature retention

### ELECTRIC

115VV / Hz / 1Ph

Cord Length (Inches): 70"

Plug Type: NEMA 5-15P

Cord set included

NEMA 5-15P



### 3RD PARTY APPROVALS



### WARRANTY (USA / CANADA)

One (1) Year Limited Warranty on Parts and Labor, One (1) Year Warranty on Compressor and Evaporator

Contact us for details at 1.877.368.2797



### STORAGE CAPACITY

- Cubic Feet: 15.4 Cu. Ft.

### TEMPERATURE

- Holding Temperature (Fahrenheit): -12 - 6.8

These models are designed to operate in an environment where temperature and humidity do not exceed 75°F (24°C) and 55% relative humidity



# Black Diamond Chest Freezer, Two Solid Doors, 15.4 Cu. Ft.

BDCF-16/2R

FRONT

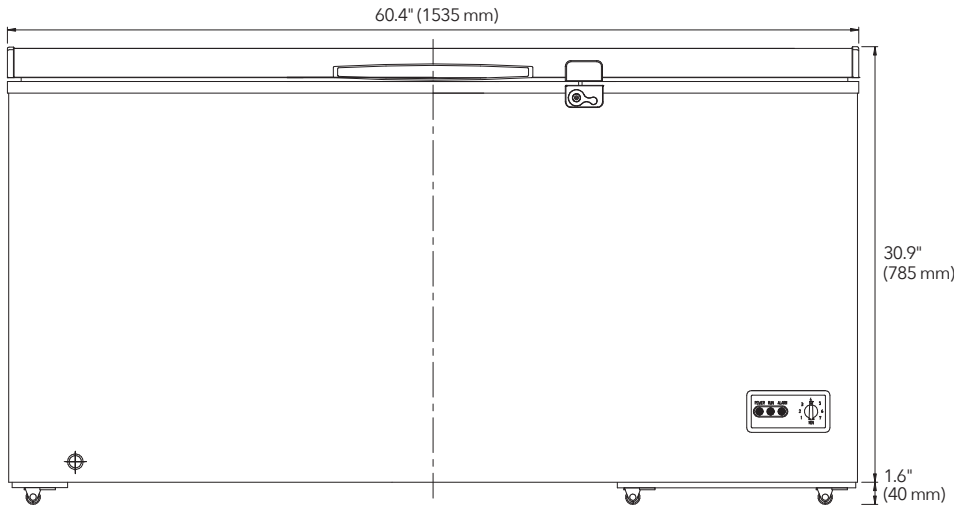

SIDE

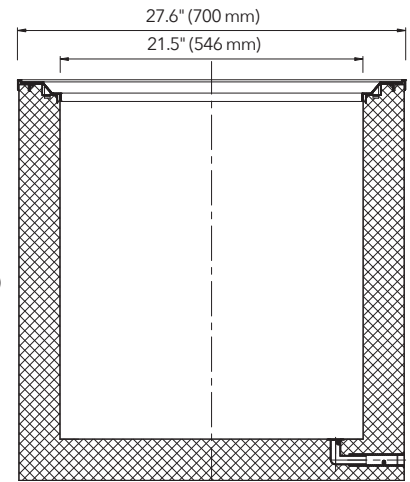
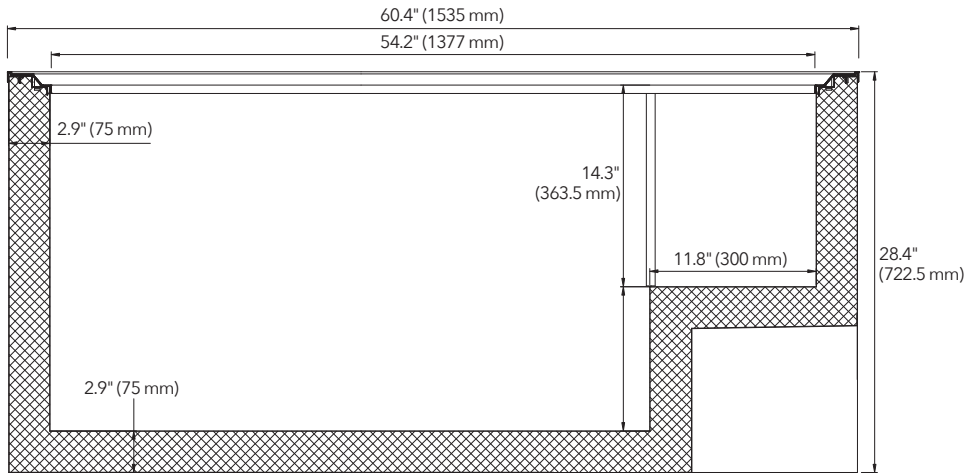
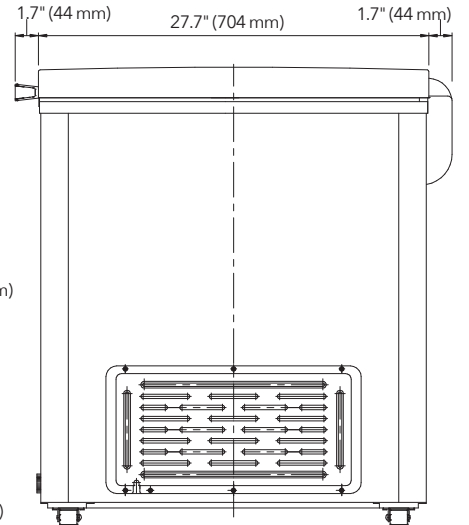

## Chest

Doors	Baskets Included	Casters	Refrigerant	Amps	HP	Wattage	Assembled Dimensions (in)	Item Weight (lbs)	Shipping Weight (lbs)
2	2	4	R290a 1.94 oz	1.9A	1/8	215W	27.72" x 60.43" x 32.48"	138.9	165.3

Due to periodic changes in designs, methods, procedures, policies and regulations, the specifications contained in this document are subject to change without notice. While we exercise good faith efforts to provide information that is accurate, we are not responsible for errors or omissions in information provided or conclusions reached as a result of using the specifications. By using the information provided, the user assumes all risks in connection with such use.