

# How to Use a Styling Design Ruler

**Rulers are essential for your sewing room.** They come in a variety of shapes and sizes, many with specific purposes. The Styling Design Ruler is one that does many things. Once you understand the reason for the curves and markings, you won't want to be without it!

## You will need:

- Styling Design Ruler
- Marking pencils
- Flexible See-Thru Ruler
- Your garment or pattern
- Tissue paper or tracing paper

## Optional for making patterns:

- Grid-marked pattern paper or craft paper

## Optional for modifying apparel:

- Dress form

The Dritz® Styling Design Ruler is laser-cut for accuracy, consistency, and smooth handling.

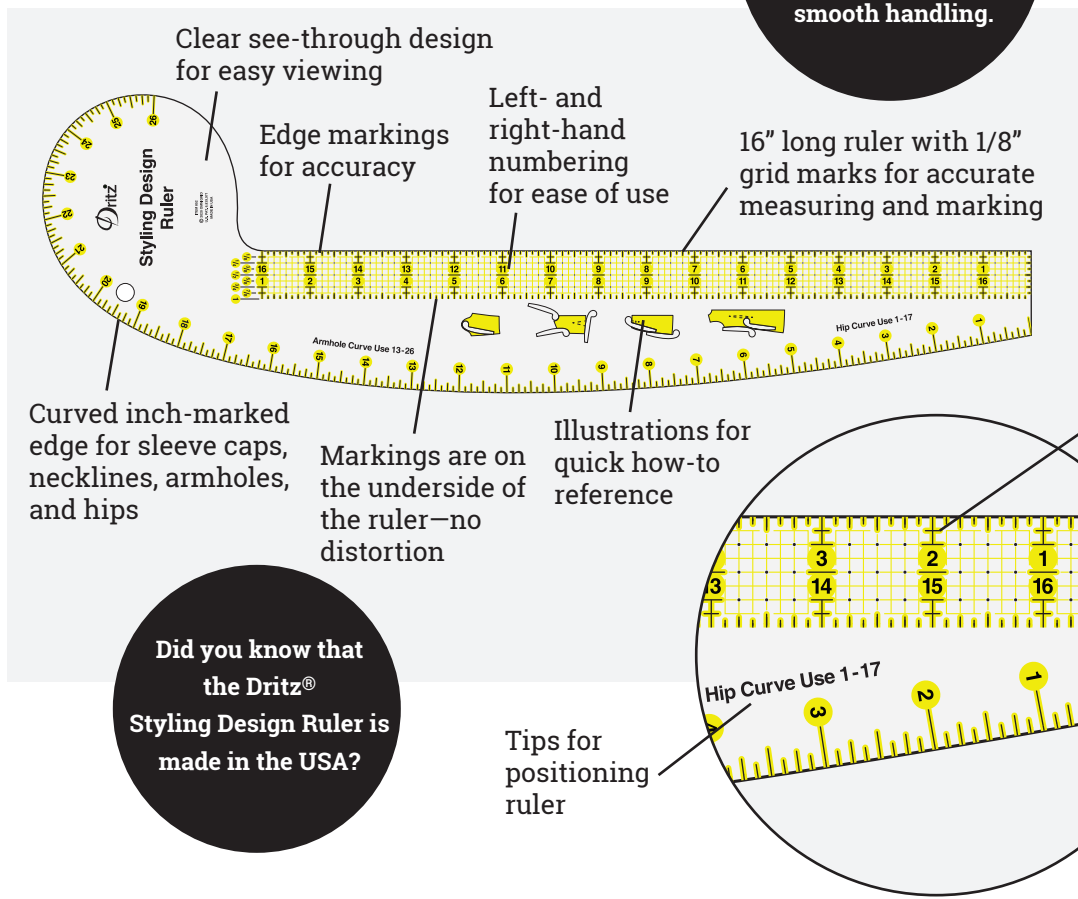

Did you know that the Dritz® Styling Design Ruler is made in the USA?



## TECHNIQUE TUTORIAL

---

You are creative. You sew. You would like to perhaps design your own clothes—or at a minimum to alter and repurpose your existing wardrobe. What tools do you need? Along with the basics like a sewing machine, scissors, tape measure, needle, thread, and your sewing pattern, rulers are at the top of the list! Rulers allow you to draw clean lines that are accurately measured and placed—a process essential for altering and fitting garments and sewing patterns. This tutorial is designed to guide you through basic pattern adjustments using the Styling Design Ruler.

Although an infinite number of measurements and line adjustments can be required—many more than can be shown in this tutorial—once you have mastered the basic ruler techniques shown here, you will be able to adjust any design line necessary. The Styling Design Ruler offers features that allow the user to simply align an edge to a seam line and slide or pivot to a new point for quick and accurate changes. Enjoy! This is the beginning of a fantastic wardrobe!

## ILLUSTRATED INSTRUCTIONS

---

Pages 1–2	<b>Lowering or raising an armhole</b>
Pages 3–4	<b>Increasing or decreasing shoulder width at an armhole</b>
Pages 5–6	<b>Lowering or raising a shoulder</b>
Pages 7–8	<b>Decreasing a sleeve cap</b>
Pages 9–10	<b>Increasing or decreasing the side seam of a bodice</b>
Pages 11–12	<b>Lowering or raising a neckline</b>
Pages 13–14	<b>Shortening a bodice</b>
Page 15	<b>Shortening a bodice at the lengthen/shorten line of a pattern</b>
Pages 16–17	<b>Lengthening a bodice at the lengthen/shorten line</b>
Pages 18–19	<b>Adjusting darts</b>
Pages 20–21	<b>Increasing or decreasing the waist of a skirt</b>
Pages 22–25	<b>Increasing or decreasing the hip area on a skirt</b>
Pages 26–28	<b>Reducing the waist of a one-piece dress</b>
Pages 29–31	<b>Enlarging the waist of a one-piece dress</b>
Page 32	<b>Useful tips and ideas</b>



## Lowering or raising an armhole

Determine the amount by which you plan to change your pattern. Mark the measured amount up or down from the armhole/side seam intersection with a dot (1). If enlarging, you may need to tape additional tissue paper to the pattern to extend the edges (not shown).

Line up the ruler so it touches the armhole/shoulder seam intersection (2). Slide the ruler down so the curved end touches the dot (3). With the ruler touching both the armhole/shoulder seam and the dot at the armhole/side seam (3), draw in the new line using the edge of your ruler as a guide. The red line is your new seam line (4).

(Instructions for lowering or raising an armhole continue on the next page.)

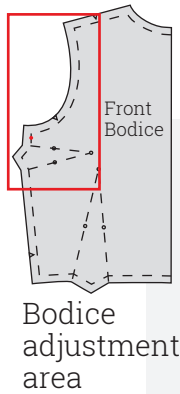

Illustrations show lowering an armhole.

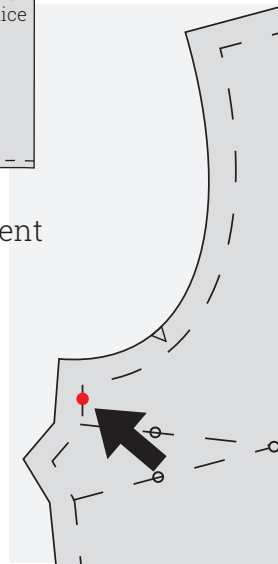

1. Make a dot at intended new line position.

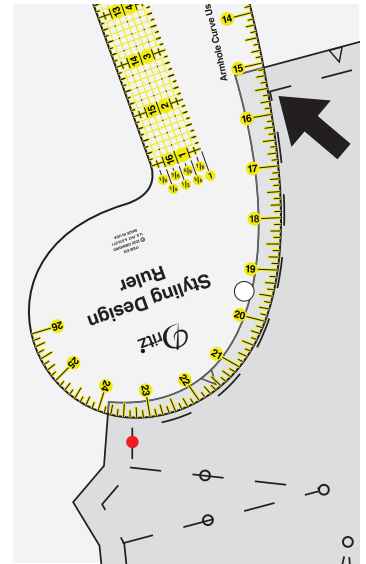

2. Place ruler at armhole/shoulder seam line.

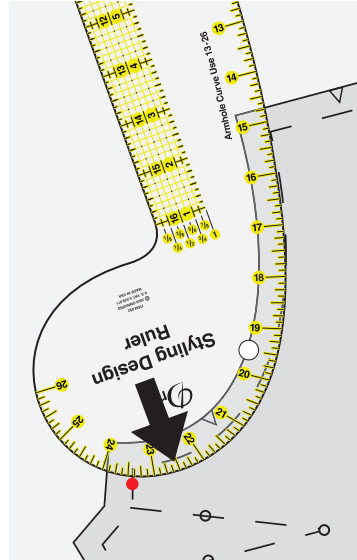

3. Slide ruler to the new dot.

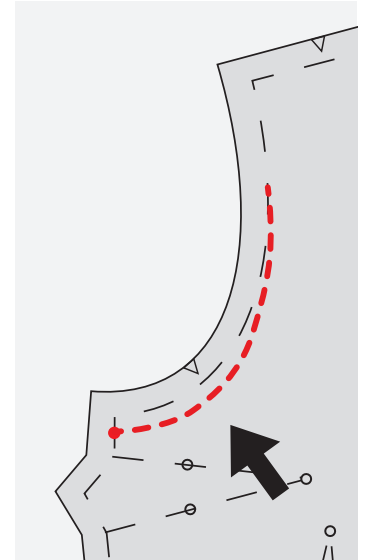

4. Draw in new line.

### ALTERNATE METHOD

All instructions and diagrams are shown as pattern pieces. However, the same techniques will work on an actual garment. Some manipulation is required, however. Turn the garment wrong side out. Work on a flat surface; smooth the garment so there are no twists or wrinkles. Carefully mark changes with tailor's chalk or removable ink.



## Lowering or raising an armhole (continued)

Once your new seam line is marked, you must adjust the seam allowance accordingly. To do this, use the straight edge of the styling ruler. Measure the required amount out from the seam line (5/8", for example), placing dots along the armhole curve (5).

Then turn the ruler and align the curved edge with the new marks (6). Use the edge of the ruler as a guide to draw in the new seam allowance, blending the line to meet the original pattern line (7).

Repeat the process for both the front and back pattern pieces. They must match. Also be sure to adjust any facing or sleeve that will be attached to the armhole.

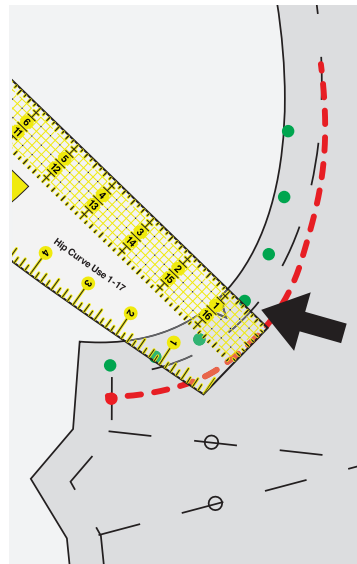

5. Use grid-marked straight edge of ruler to measure and mark seam allowance.

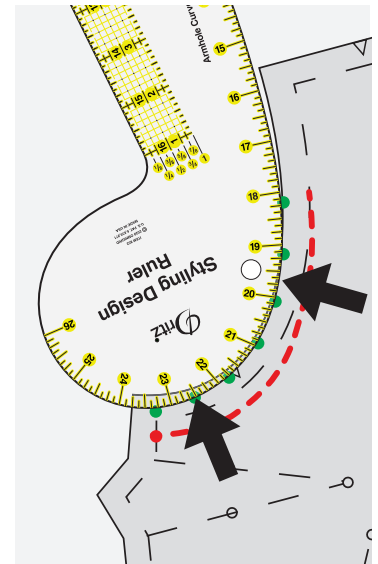

6. Position ruler along marked seam allowance as a guide for new line.

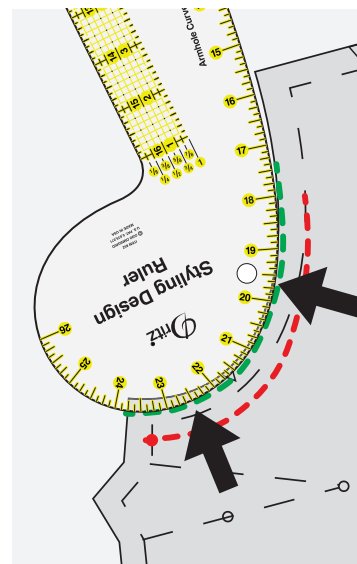

7. Draw in new line for seam allowance.

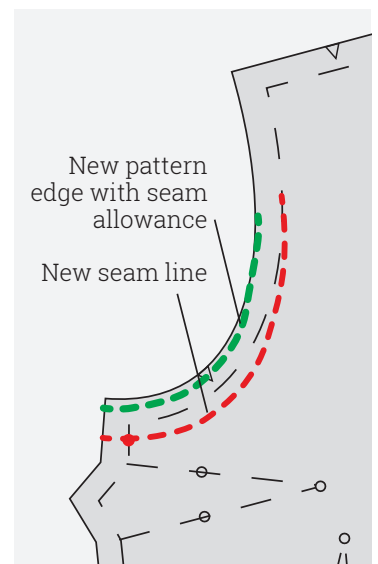

Completed new seam line and seam allowance line



## Increasing or decreasing shoulder width at an armhole

Determine the amount by which you plan to change your pattern.

Mark this amount on the shoulder seam line at the armhole/shoulder intersection with a dot (1). If enlarging, you may need to tape additional tissue paper to the pattern to extend the edges (not shown).

Line up the ruler so it touches the armhole/side seam intersection (2). Holding the ruler at the armhole/side seam intersection, pivot the ruler so it touches the dot at the armhole/shoulder intersection (3). Draw in the new line using the edge of your ruler as a guide (4).

(Instructions for increasing or decreasing shoulder width at an armhole continue on the next page.)

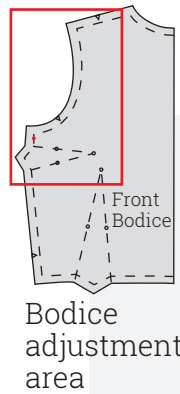

Illustrations show decreasing shoulder width.

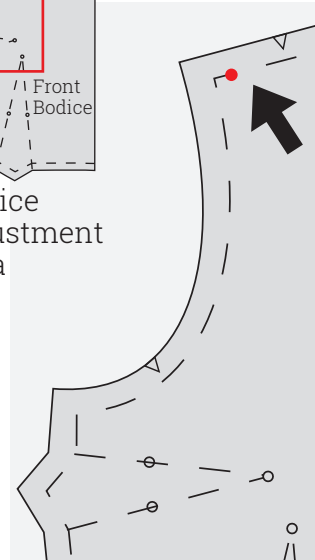

1. Place a dot at intended new line position.

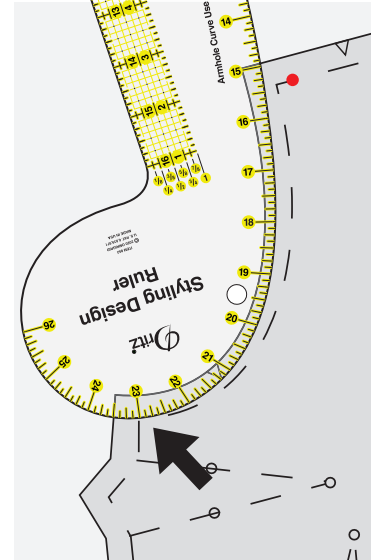

2. Position ruler so it touches armhole/side seam intersection

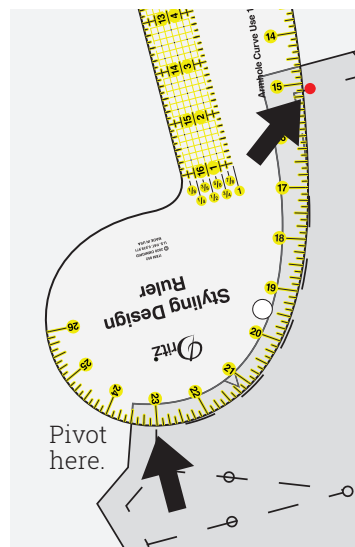

3. Pivot ruler from armhole/side seam intersection until it touches the marked dot.

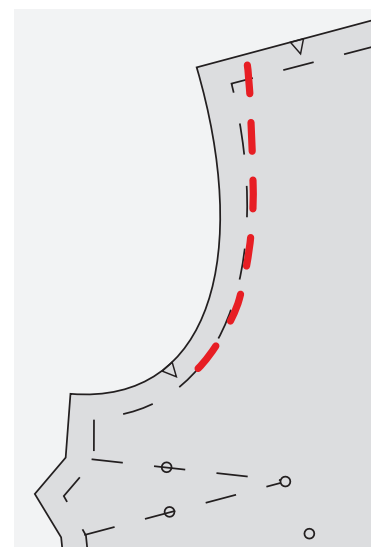

4. Draw in new line.



## Increasing or decreasing shoulder width at an armhole (continued)

Once your new seam line is marked, you must adjust the seam allowance accordingly. To do this, use the straight edge of the styling ruler. Measure the required amount out from the seam line (5/8", for example), placing dots along the armhole curve (5).

Then turn the ruler and align the curved edge with the new marks (6). Use the ruler as a guide to draw in the new seam allowance, blending in the line to meet the original pattern line at the notch (7).

Repeat the process for both the front and back pattern pieces. They should match. Also adjust any facing that will be attached to the adjusted armhole.

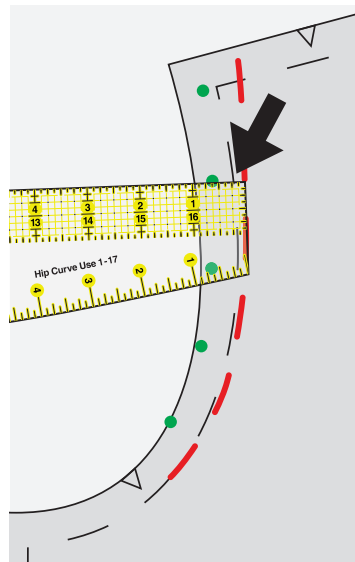

5. Use grid-marked straight edge of ruler to measure and mark seam allowance.

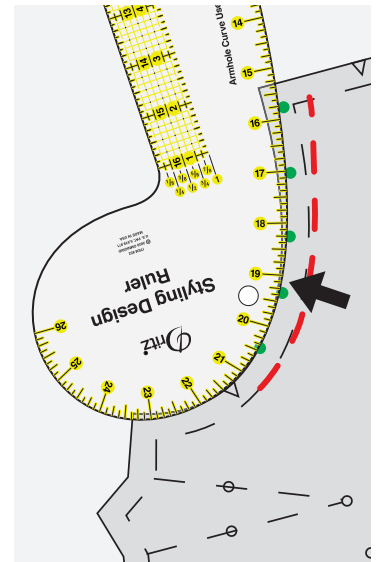

6. Position ruler along marked seam allowance as a guide for new line.

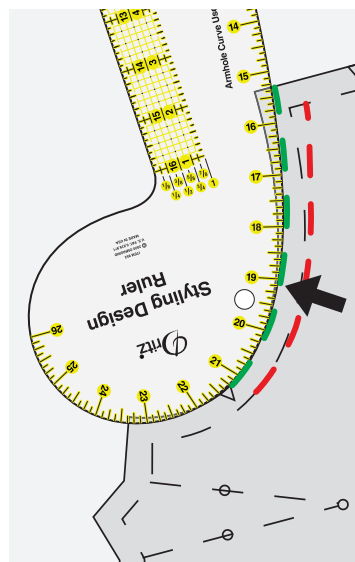

7. Draw in new line for seam allowance.

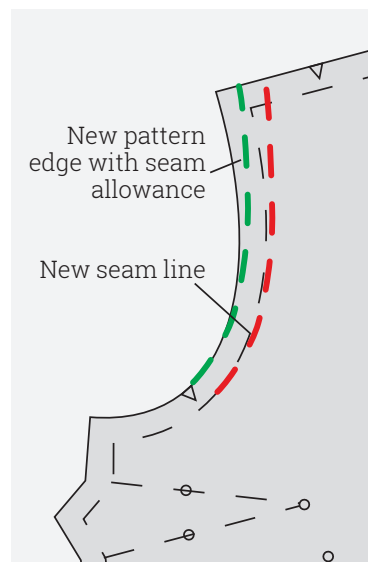

Completed new seam line and seam allowance line



## Lowering or raising a shoulder

This type of adjustment may be required if you have sloping or uneven shoulders, or if you are using a pattern designed to include shoulder pads that you will not be using. Excess fabric must be eliminated. Also adjust the shoulder seam if you have removed excessive ease from the sleeve cap. (See the section on decreasing the size of a sleeve cap.)

Determine the amount by which you plan to change your pattern.

Mark the measured amount above or below the shoulder seam line at the armhole/shoulder intersection with a dot (1). If raising the shoulder, tape tissue paper to the shoulder area (not shown).

Match the straight edge of the ruler to the pattern's shoulder seam line. Holding the ruler in place at the shoulder/neck intersection, pivot the ruler so the opposite end moves to the new dot at the armhole/shoulder intersection (2).

Use the straight edge of the ruler as a guide to draw the new raised or lowered shoulder line (3).

(Instructions for lowering or raising a shoulder continue on the next page.)

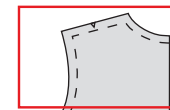

Front Bodice  
Shoulder adjustment area

Illustrations show lowering a shoulder.

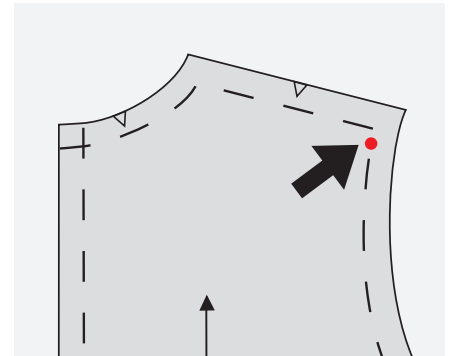

1. Place a dot at new intended position at armhole/shoulder intersection.

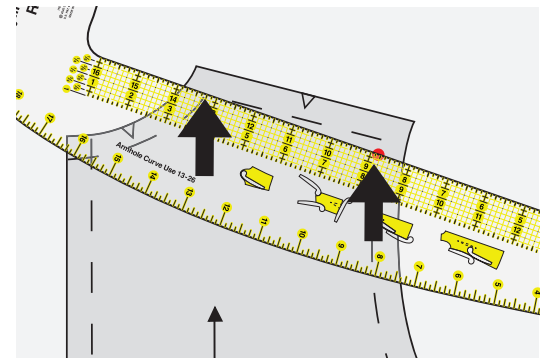

2. Hold ruler from shoulder/neck intersection and pivot so opposite end touches new dot.

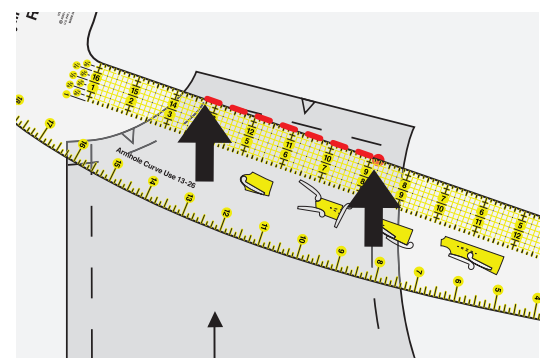

3. Draw in the new seam line.

**NOTE:** Steps are shown as a bodice shoulder adjustment, but follow the same instructions for any garment shoulder adjustment.



## Lowering or raising a shoulder (continued)

Once your new seam line is marked, you must adjust the seam allowance accordingly. Measure the required distance out from the seam line for the seam allowance (5/8", for example). The grid lines along the long straight edge of the ruler are perfect for this. Simply align the grid line matching the correct amount of seam allowance to your new seam line (4). Then draw in the new seam allowance line along the edge of the ruler (5).

Repeat the process for both the front and back pattern pieces. They must match.

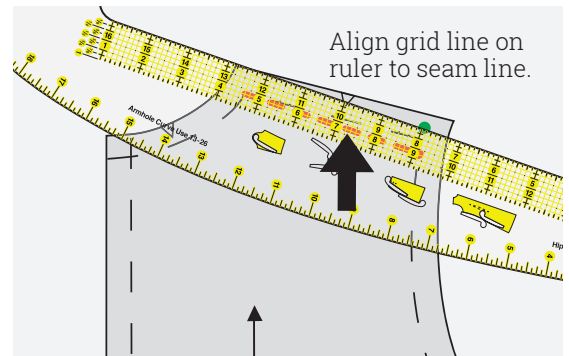

4. Use the grid-marked edge of the ruler to measure the parallel line for the shoulder seam allowance.

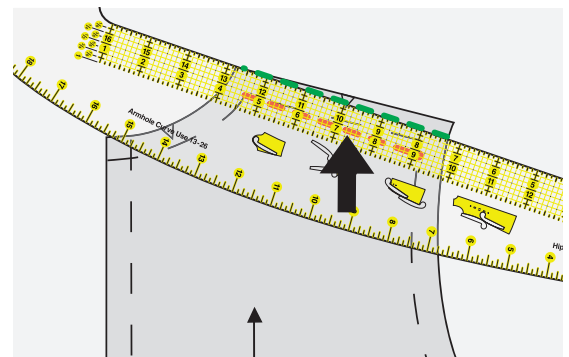

5. Use the straight edge of the ruler as a guide to draw the seam allowance.

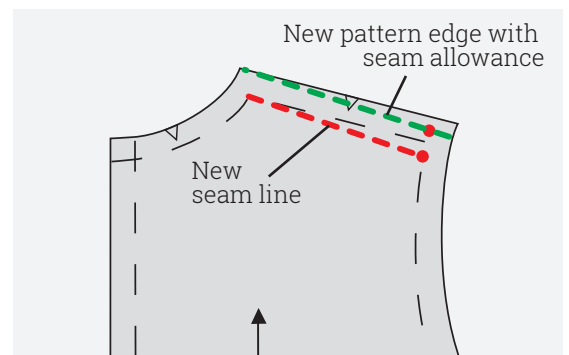

Completed new seam line and seam allowance line





## Decreasing a sleeve cap

The sleeve cap is always eased into the armhole of a garment. The amount of ease depends on the design. If fabric is stiff and difficult to ease, some reduction of the cap can help. To determine if this is required, tape the front and back pattern pieces together at the shoulder so armhole edges match. Hold a flexible ruler perpendicular to the pattern piece, using its long edge to measure between notches. Then measure the same section on the sleeve cap (not shown). Subtract the shoulder measurement from the sleeve cap measurement. The difference is the ease. About 1½"–2" is a basic amount to fit over the top of the arm. Any more than that amount can be removed. To reduce the cap size, follow the instructions shown here.

From the center of the sleeve cap measure down half the amount to be removed and place a mark (1).

Align the ruler with the original curved cap shape (2). Slide the ruler down to meet the mark. The ruler should touch both the mark and the original seam line at or just above the notch (3). (Do not change the area below the notch when making this adjustment).

Use the ruler as a guide to draw the new line on both sides of the dot, turning the ruler over and sliding it as necessary to smooth out the cap shape (4).

(Instructions for decreasing a sleeve cap continue on the next page.)

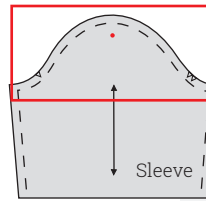

Sleeve cap adjustment area



1. Place a dot at new seam line.

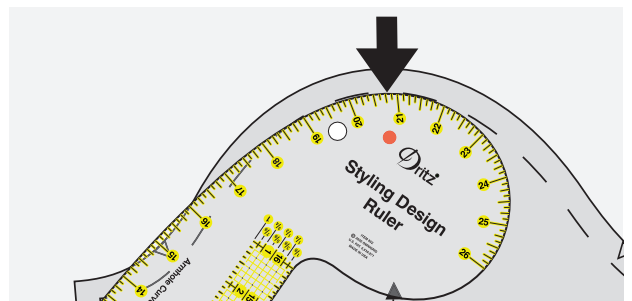

2. Align ruler with original cap shape.

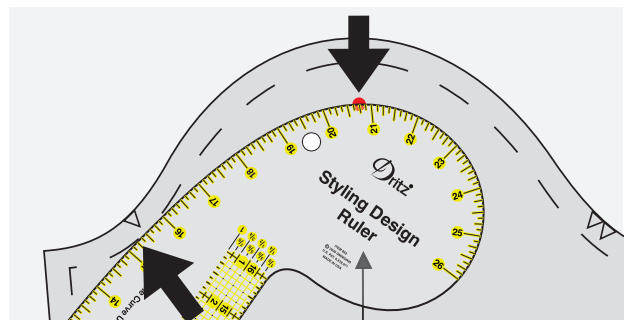

3. Slide ruler down to meet the mark.

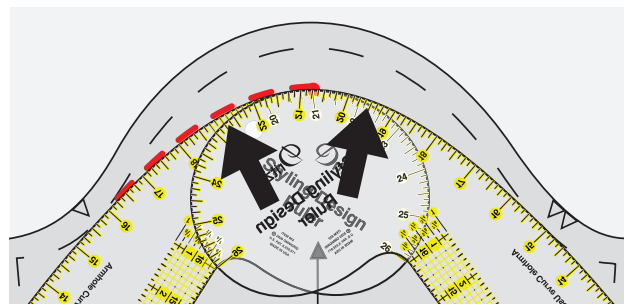

4. Slide ruler to draw the new line. Flip and slide to continue line.



Decreasing a sleeve cap (continued)

Once your new seam line is marked, you must adjust the seam allowance accordingly. To do this, use the straight edge of the styling ruler. Measure the required amount out from the seam line (5/8" for example), placing dots along the curve of the sleeve cap (5).

Align the curved edge of the ruler with the new marks (6). Use the edge of the ruler as a guide to draw in the new seam allowance, blending in the line to meet the original pattern line (7).

Always test the adjusted cap by sewing a sample from muslin or scrap fabric to make sure the cap fits the shoulder properly.

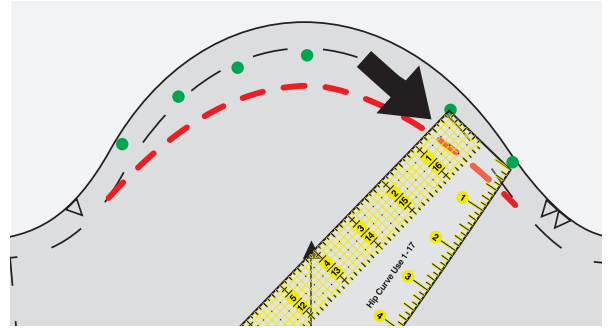

5. Measure out from seam line for new seam allowance.

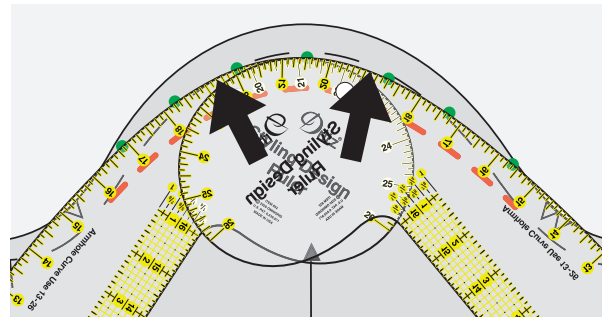

6. Align curved edge of ruler to new marks.

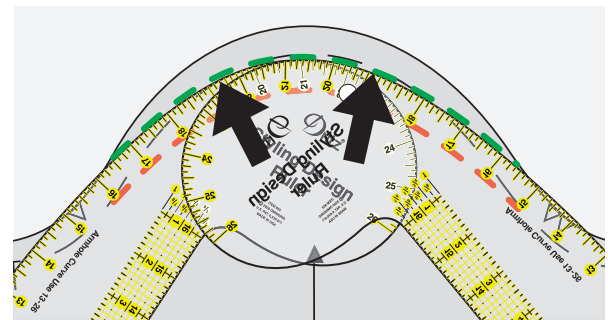

7. Draw in the new seam allowance line.

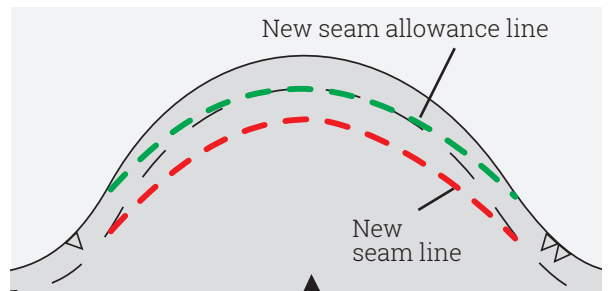

Completed new seam line and seam allowance line



## Increasing or decreasing the side seam of a bodice

Determine the amount by which you plan to change your pattern. If needed, tape additional tissue paper to the pattern to extend the edges (not shown).

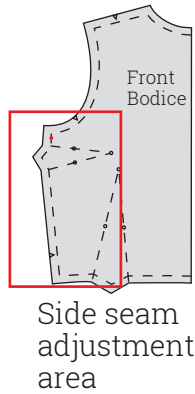

Fold the legs (seam lines) of any side dart together by folding the bottom leg line up to meet the top leg line so center of dart folds down (1). Tape to secure (tape not shown in diagram).

Mark the measured amount in or out from the armhole/side seam intersection with a dot (1).

The side seam might be straight or slightly curved. Use the section of the ruler most similar in shape to the side seam line when drawing the new line (2).

Holding the ruler at or just above the waist, pivot the ruler so that the opposite end touches the new dot (3). Use the ruler as a guide to draw the new line (4).

(Instructions for increasing or decreasing the side seam of a bodice continue on the next page.)

**NOTE: Illustrations show this adjustment as a bodice side seam, but the technique is the same for garments such as jackets or dresses. Always modify any sleeve or facing to match the side seam adjustment.**

Illustrations show decreasing a bodice side seam.

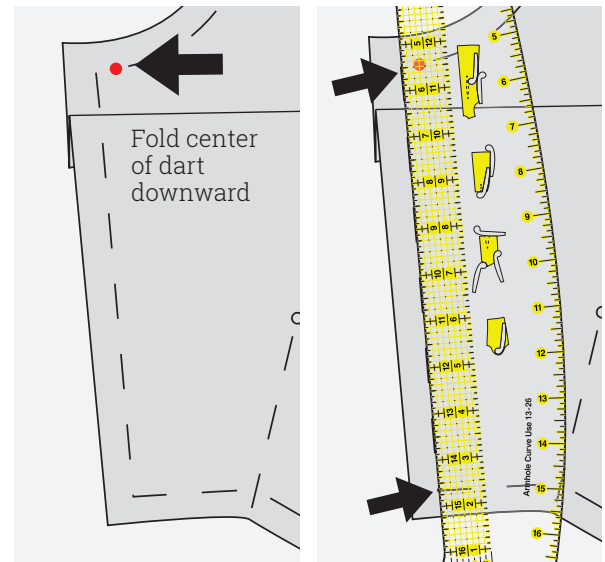

1. Place a dot at new line position.

2. Choose ruler edge that matches seam line.

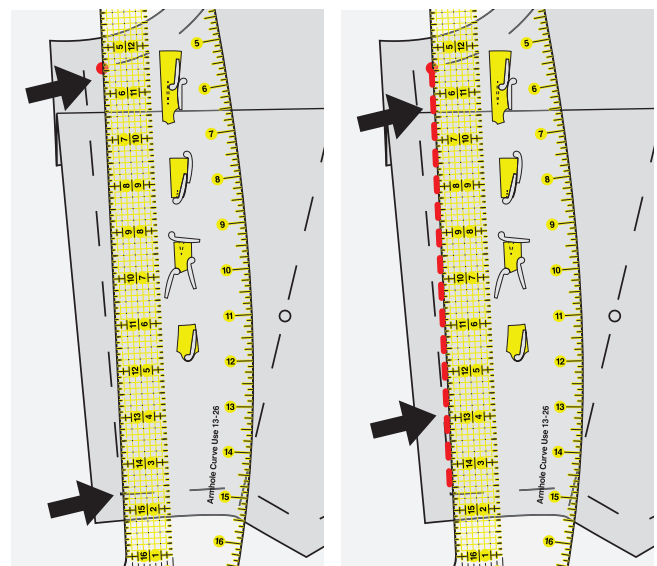

3. Pivot ruler from waist to new dot.

4. Use ruler as a guide to draw the new line.



**Increasing or decreasing the side seam of a bodice (continued)**

Once your new seam line is marked, you must adjust the seam allowance accordingly. The long, straight grid-marked edge of the ruler is perfect for this. Simply line up the grid line that matches the amount of seam allowance (5/8" for example) to the new seam line (5). Then draw in the new seam allowance line parallel to the seam line, using the ruler as a guide (6).

**ALTERNATE METHOD**

*If the seam is slightly curved instead of straight, turn the ruler and use the grid-marked section to place dots at the appropriate distance along the curve (7). Then draw the new line (8).*

Cut along the new pattern edge; then unfold the dart (9). Because you folded the dart before measuring and cutting, the original shape of the dart edge will be maintained.

Make the same adjustments to the back side seam. The back seam will most likely not have a side dart to fold as part of the process.

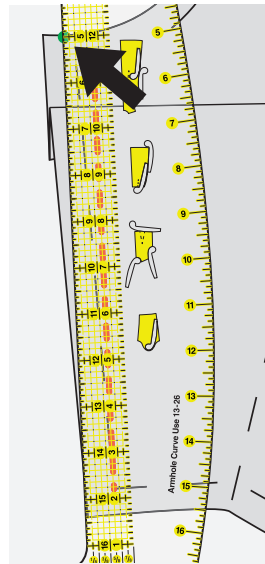

5. Use grid-marked edge to measure seam allowance.

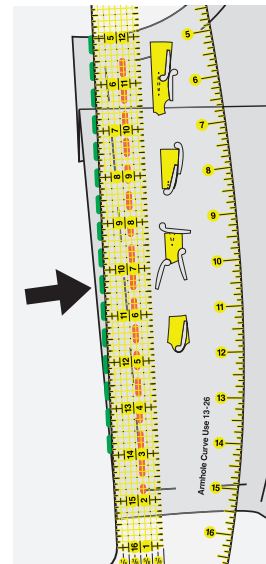

6. Draw new seam allowance line.

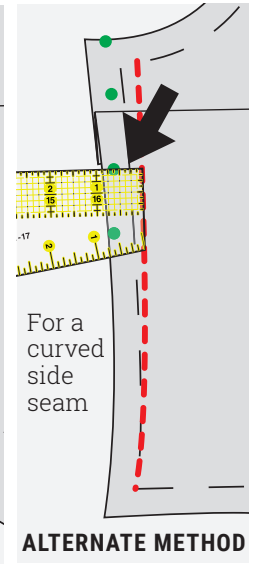

**ALTERNATE METHOD**

7. Turn ruler to measure new seam allowance for curved edge.

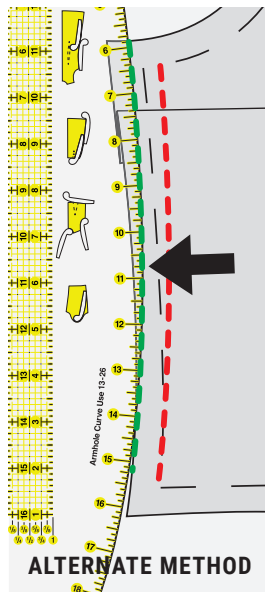

8. Use the curved edge to draw the new lines.

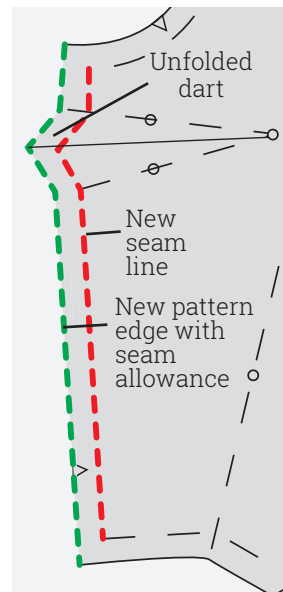

9. Cut edge and unfold dart to complete the pattern adjustment for either method.



## Lowering or raising a neckline

This adjustment may be done to the front or the back of a pattern.

Determine the amount by which you plan to change your pattern. Mark the measured amount down from the center front or center back neck intersection and place a dot (1).

Match the curve of the ruler to the pattern's neckline seam line (2). Slide the ruler down to the dot. Make sure the ruler continues to touch the shoulder/neck seam intersection as it moves to the dot (3). Use the ruler as a guide to draw in the new neckline (4).

(Instructions for lowering or raising a neckline continue on the next page.)

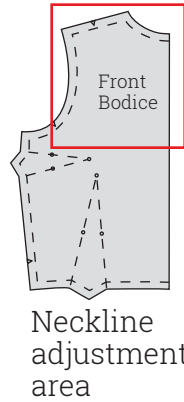

Illustrations show lowering a neckline.

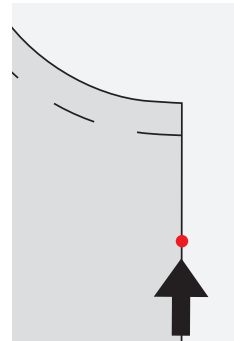

1. Place a dot at new position at center front.

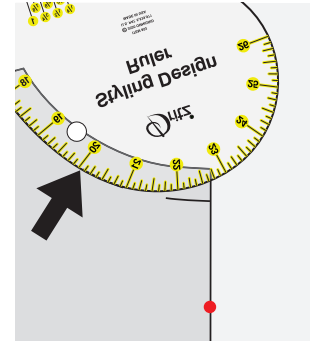

2. Match ruler to pattern's current neckline curve.

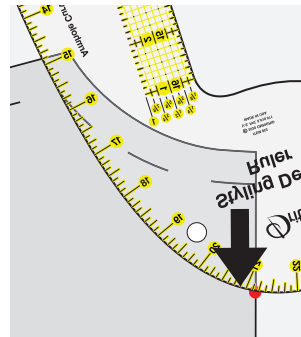

3. Slide ruler down to new dot, making sure it touches neckline/shoulder intersection.

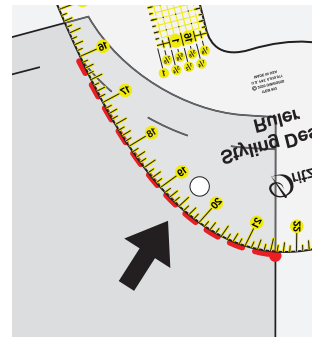

4. Draw new line.

### ALTERNATE METHOD

For stylized necklines, follow these instructions, except draw in the lowered neckline with multiple dots (5). Draw the new line in stages to blend the shape smoothly (6).

### ALTERNATE METHOD

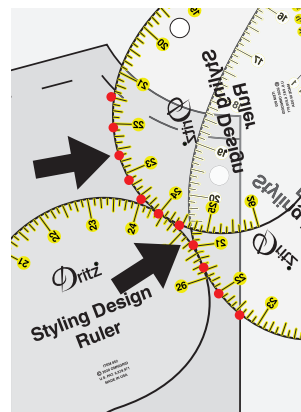

5. Use multiple dots for stylized neckline curve.

### ALTERNATE METHOD

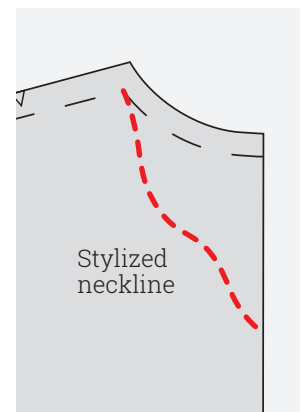

6. Draw new line moving ruler to blend curves.



## Lowering the neckline (continued)

The new line should be drawn at a right angle where it meets the center front or center back. Use the grid-marked straight edge of the ruler to adjust the last 1/8" of the line (7).

Once your seam line is marked, you must adjust the seam allowance accordingly. To do this, use the straight edge of the styling ruler. Measure the required amount out from the seam line (5/8", for example), placing dots along the neckline curve (8).

Then turn the ruler, aligning the curved edge with the new marks (9). Use the ruler as a guide to draw in the new seam allowance, blending in the line as needed to meet the original pattern line (10).

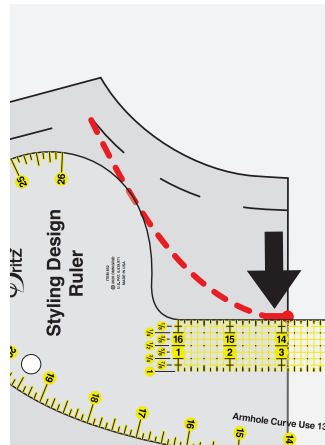

7. Adjust the last 1/8" of the new line to be at a right angle to the center front.

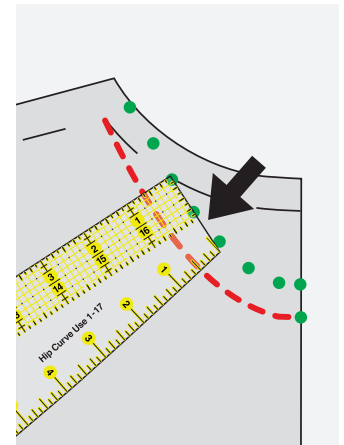

8. Measure and mark the seam allowance.

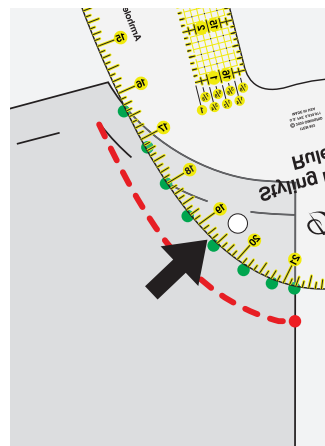

9. Align the curved section to the dots.

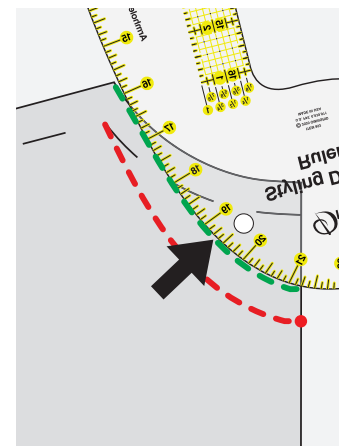

10. Draw the new seam allowance.

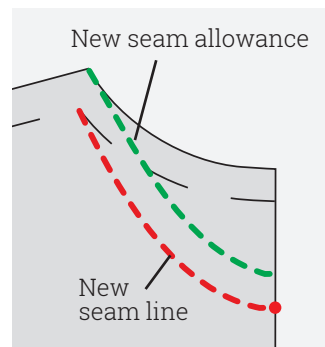

Completed new seam line and seam allowance line



## Shortening a bodice

The bodice of a garment usually tapers at the waistline; slight shortening may not affect the fit. However, the more a bodice is shortened, the larger the waist becomes. Conversely, the more a bodice is lengthened, the smaller the waistline becomes. Test-fit the adjusted pattern with muslin or scrap fabric after making adjustments to avoid any unexpected results.

Determine the amount by which you plan to change your pattern. Make several dots in the measured amount up from the pattern's waistline seam line, spreading the dots across the width of the bodice (1).

NOTE: Before drawing in a new line, fold any waist darts toward the center (not shown).

Match the curve of the ruler to the pattern's existing waistline seam line (2), and slide it up to the new dots (3). Draw in the new shortened bodice seam line (4).

(Instructions for shortening a bodice continue on the next page.)

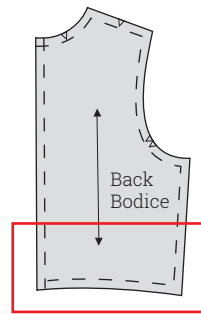

Bodice length adjustment area

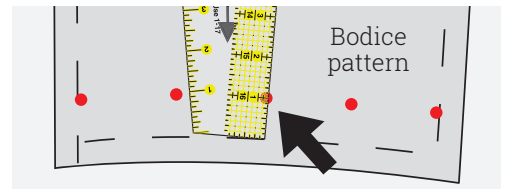

1. Measure and mark new waistline position.

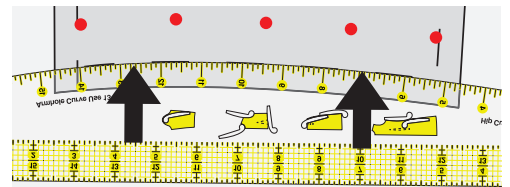

2. Match ruler curve to current seam line.

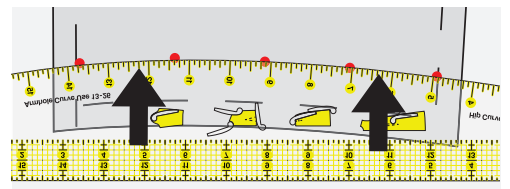

3. Slide ruler to new marks.

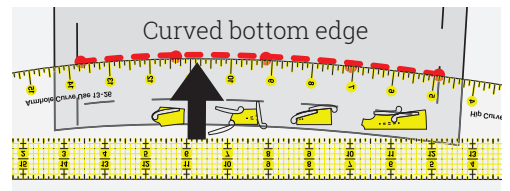

4. Draw the new seam line using the ruler as a guide.

### ALTERNATE METHOD

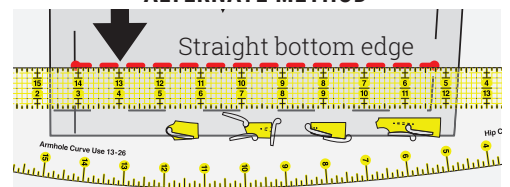

5. Use straight edge of ruler if bottom edge of bodice is straight.

### ALTERNATE METHOD

If the bodice waistline edge is straight, use the grid-marked straight edge of the ruler. Slide the ruler up the desired amount of adjustment and draw the new seam line (5).



## Shortening a bodice (continued)

Once your seam line is marked, you must adjust the seam allowance accordingly. To do this, use the grid-marked edge of the ruler to measure down the required distance (5/8", for example) for the seam allowance (6).

Turn the ruler and align the curved edge with the new marks (7). Use the ruler as a guide to draw in the new seam allowance (8). If the edge is straight, simply align the correct seam measurement on the long straight edge to the dots and, then use the ruler edge as a guide to draw in the new seam allowance. (Also see the alternate method of using a lengthen/shorten line shown on the next two pages.)

Repeat the process for both the front and back pattern pieces. Even if the center front and center back adjustments are not the same, the side seams must match.

**NOTE:** These instructions apply only if the bottom edge of the bodice is the waistline. If it is not, use the shorten/lengthen line technique explained on the following pages.

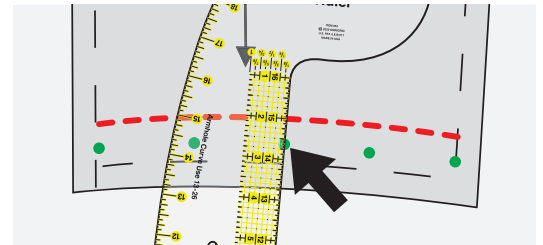

6. Measure and mark new seam allowance.

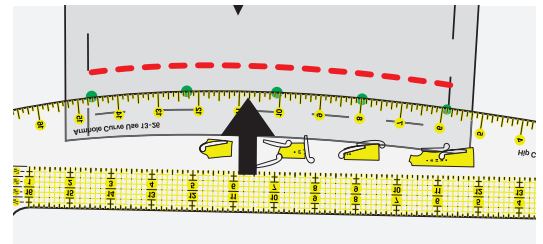

7. Align curved edge to marks.

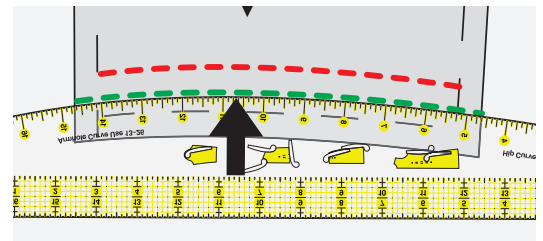

8. Use ruler as guide to draw seam allowance.

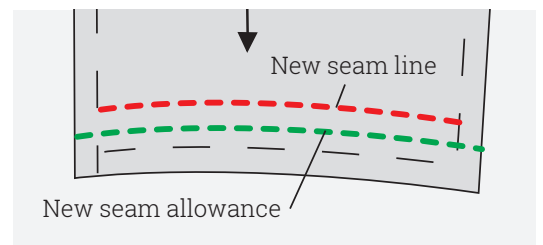

Completed seam line and seam allowance.





## Shortening a bodice at the lengthen/shorten line of the pattern

If your pattern has a dropped, raised, or angled waistline, adjusting it from the bottom edge may distort the proportion. Instead, shorten it at the lengthen/shorten line printed on the pattern.

Determine the amount to be shortened. Make a dot this distance from the lengthen/shorten line (1). Use the grid-marked edge to draw a line at the dots. This should be parallel to the lengthen/shorten line (2).

Fold the pattern at the new line, bringing it up to meet the lengthen/shorten line. Tape in position (3). The side seam may now be uneven (3). If this is the case, tape a piece of tissue paper under the pattern so you can straighten the edge (4).

To straighten the side edge, match the ruler edge to the seam line at the armhole/side seam intersection. Holding the ruler at that point, pivot the ruler so it touches the side seam/bottom seam line intersection. Using the straight edge of the ruler as a guide, mark a new blended seam line (4). Line up the grid-marked edge with the seam line and move the ruler out the required distance for the seam allowance (5/8" for example). Draw a new line for the seam allowance (5).

Repeat the process for both the front and back pattern pieces. The side seams must match.

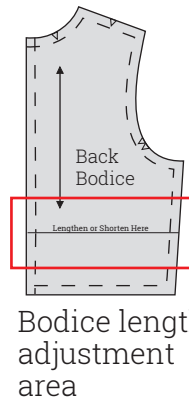

Illustrations show shortening a bodice.

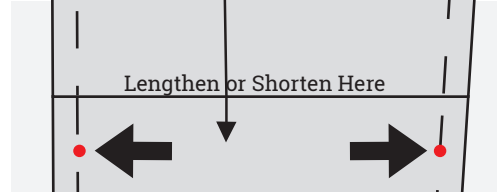

1. Mark the amount to be shortened.

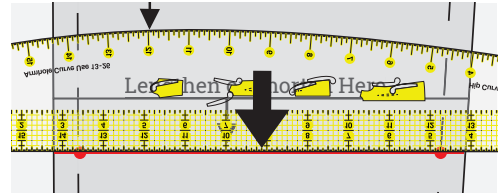

2. Use ruler as a guide to draw a new line.

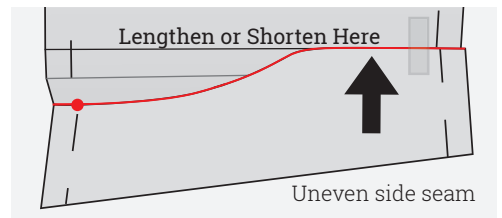

3. Fold pattern on new line; tape folded line to the lengthen/-shorten line.

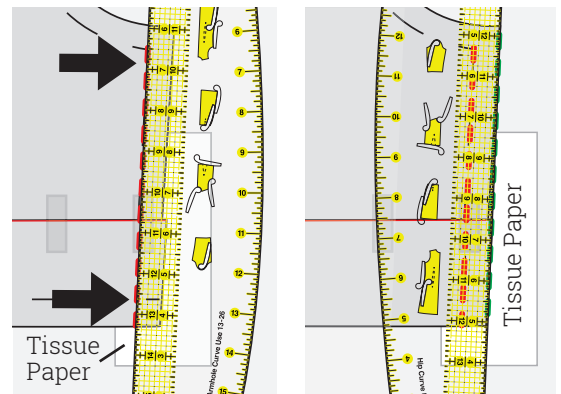

4. Add tissue paper. Match ruler edge to side seam/armhole intersection and side seam/bottom intersection. Draw the blended seam line.

5. Use the ruler as a guide to draw a parallel line for the seam allowance.



## Lengthening a bodice at the lengthen/shorten line

Determine the amount by which you plan to change your pattern.

Cut the pattern along the lengthen or shorten line. Tape a piece of tissue paper to the top section of the pattern (1). Mark the amount to be lengthened with dots. Place the ruler edge on the dots, making sure the grid lines are parallel to the lengthen/shorten line. If the amount to be lengthened is less than an inch, simply line up the appropriate grid line on the ruler to the cut edge of the lengthen/shorten line (2). Use the ruler edge as a guide to mark a parallel line on the pieced tissue paper (3).

(Instructions for lengthening a bodice at the lengthen/shorten line continue on the next page.)

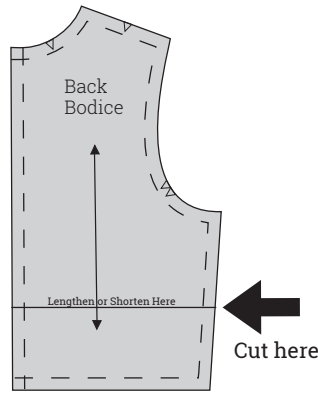

Bodice length adjustment area

If there is no lengthen/shorten line, draw one on the pattern. Use straight edge of ruler to draw a line perpendicular to the grainline 4" above waistline. If line crosses a dart, adjust dart lines as in step 6 on next page.

Illustrations show lengthening a bodice.

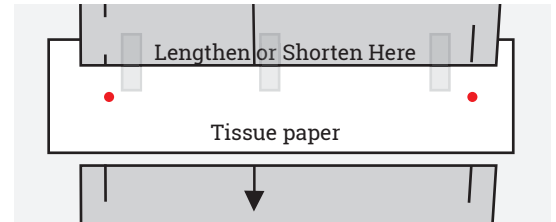

1. Cut the pattern on the lengthen or shorten line. Tape tissue paper to top pattern piece. Place dots.

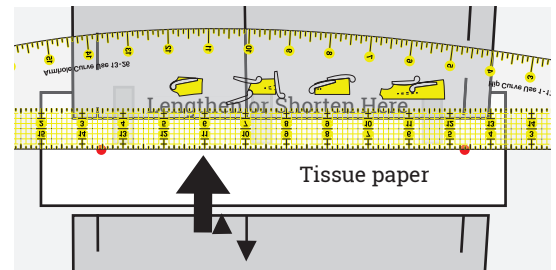

2. Line up ruler to dots.

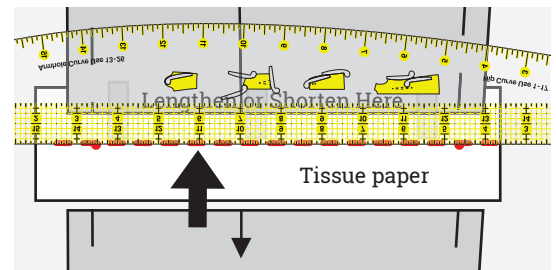

3. Use ruler edge as a guide to draw a new line on the tissue paper.

### ALTERNATE METHOD

If the amount to be lengthened is greater than an inch, make multiple markings below the lengthen/shorten line on the tissue paper. Then line up the straight edge of the ruler with the new marks. Use the ruler as a guide to draw a line on the marks parallel to the lengthen/shorten line. Extend the grainline arrow. Line up the bottom half of the pattern to the new line, making sure the lines of the grainline arrow match. Tape the extension in place.



## Lengthening a bodice at the lengthen/shorten line (continued)

Extend the grainline arrow (4). Tape the cut edge of the lower part of the bodice to the new line, matching the grainline arrow (5).

The top and bottom sections might not line up at the side edge. Use the ruler as a guide to connect top and bottom side seams, blending as needed for a smooth transition (6). Trim away excess tissue paper along blended side seam allowance edge (7).

Repeat the process for both the front and back pattern pieces. The side seams must match.

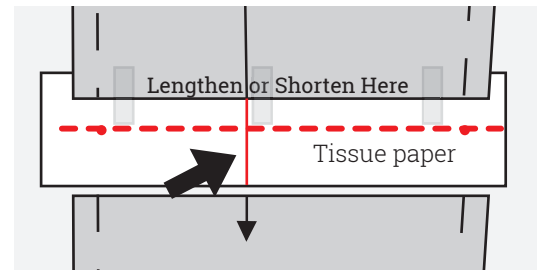

4. Extend the grainline arrow.

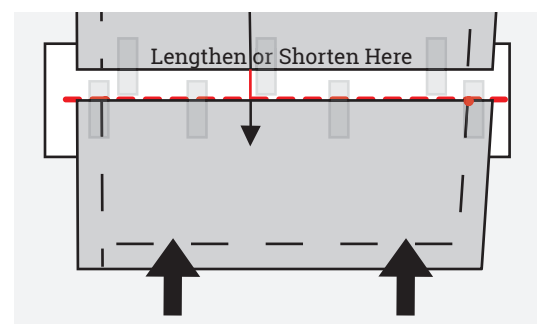

5. Tape the lower part of bodice to tissue, making sure grainline matches.

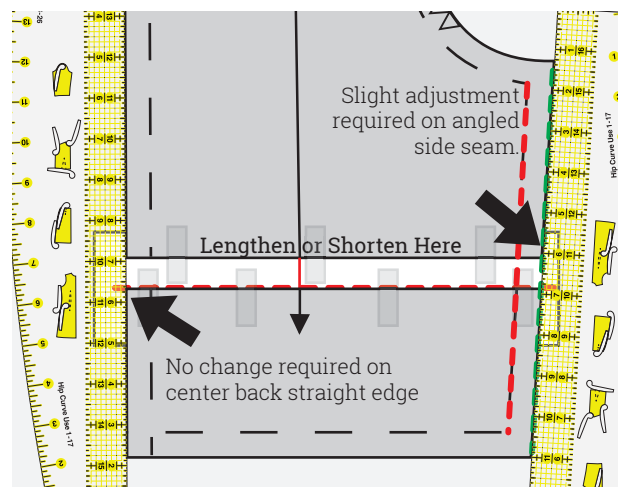

6. Adjust seams using the ruler as a guide.

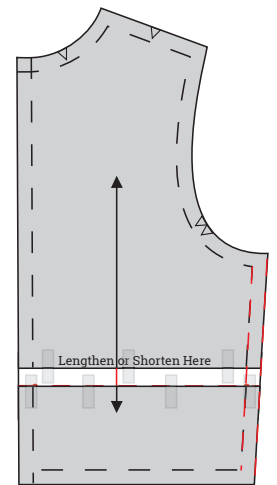

7. Completed lengthened bodice



## Adjusting darts

Darts are designed to pinch in the fabric to create a flattering fit. They can be straight or they might curve in or out. Bodice darts curve inward to allow for a fuller rib cage, or curve outward to fit a smaller rib cage. Hip darts usually curve inward to fit over the fullness of that area. Follow these instructions to change a dart from a straight dart to a dart curving inward or outward.

To adjust darts on a flat pattern, place a mark halfway down on each of the dart's legs (1).

### For an inward-curving dart:

At the halfway mark, make another dot no more than 1/8" inside each leg line to create an inward curving dart (2).

Place the curve of the ruler on the dart so it touches the tip, the new dot, and the end of the dart leg (3). Draw in the new curved dart using the ruler as a guide (4).

(Instructions for adjusting darts continue on the next page.)

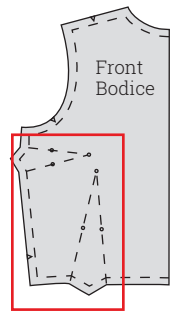

Dart adjustment area

Illustrations show creating an inward-curving dart.

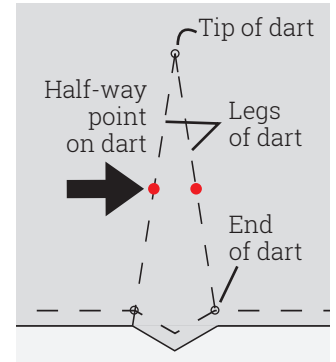

1. Place dots at halfway points on dart legs.

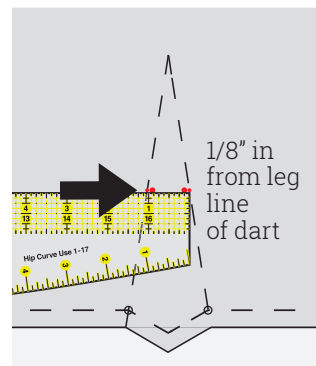

2. Place a dot 1/8" in from each side at halfway points on dart legs.

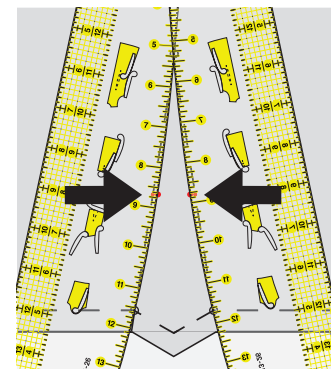

3. Place ruler so it touches the tip, the dot and the end of the dart leg.

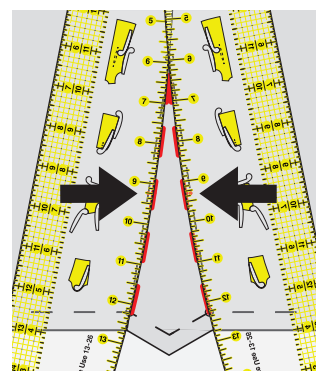

4. Use the ruler to draw in the new dart.

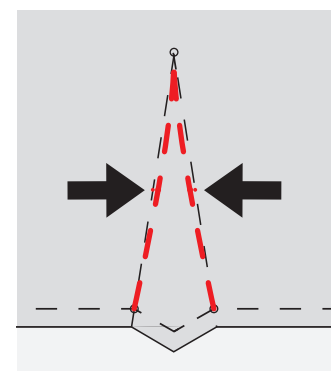

Completed inward-curving dart

Did you know that the seam lines of a dart are called the "legs" of the dart?



**Adjusting darts (continued)**

**For an outward-curving dart:**

To adjust darts on a flat pattern, place a mark halfway down on each of the dart's leg lines (1).

At the halfway mark, make another dot no more than 1/8" out from the leg line to create an outward-curving dart (2).

Place the curve of the ruler on the dart so it touches the tip, the new dot, and the end of the dart leg (3). Draw in the new curved dart using the ruler as your guide (4).

Illustrations show creating an outward-curving dart.

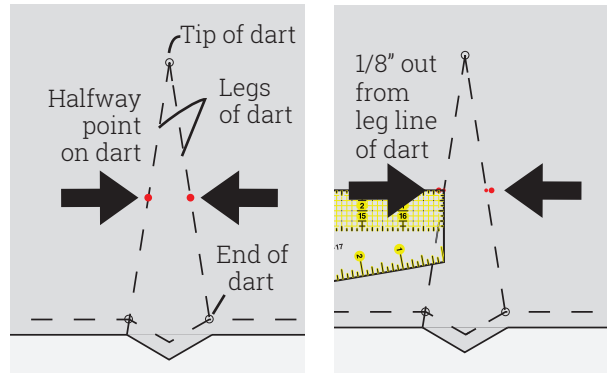

1. Place dots at the halfway points on dart.
2. Place a dot 1/8" out from each leg at half-way point on dart.

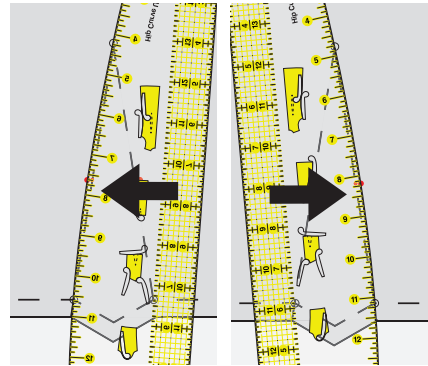

3. Place ruler so it touches the tip, the dot and the end of the dart leg on both sides of the dart.

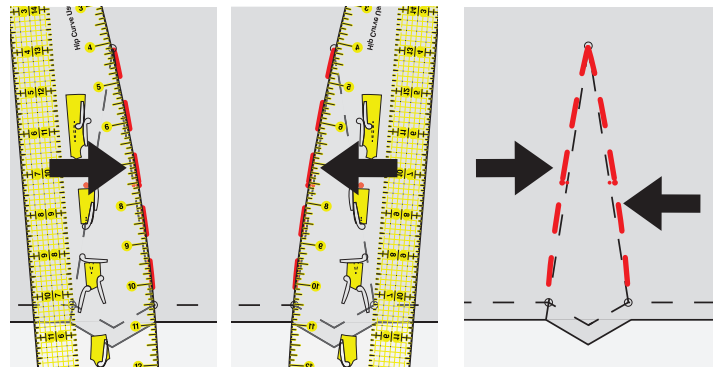

4. Use the ruler to draw in the new dart lines on both sides.
- Completed outward-curving dart



## Increasing or decreasing the waist of a skirt

Determine the amount by which you plan to change your pattern. If increasing, tape tissue paper to the pattern from waist to hip (1). Mark the measured amount out from the waist/side seam intersection with a dot (1).

Match the curve of the ruler as closely as possible to the curve of the pattern's side seam line (2). Hold the ruler in place on the side seam line 7–9" below the waist/side seam intersection and pivot the ruler to the waistline dot (3).

Use the ruler as your guide to draw in the new seam line (4).

(Instructions for increasing or decreasing the waist of a skirt continue on the next page.)

**TIP: Always use dots when making marks. They are much more exact and offer better fitting results.**

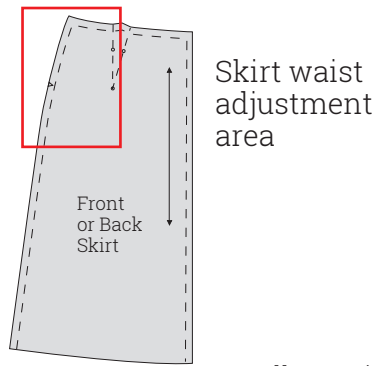

Illustrations show increasing the waist.

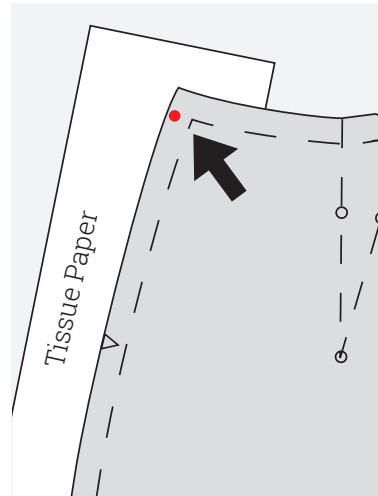

1. Add tissue paper from waist to hip. Mark the adjusted amount out from side seam at waist.

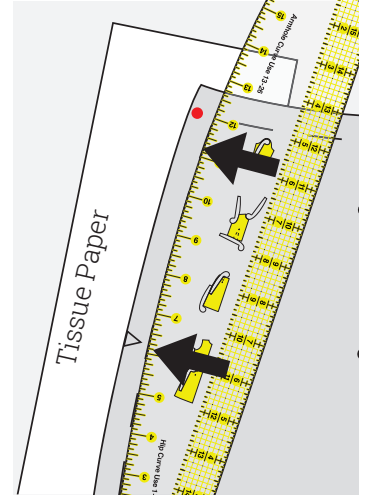

2. Match curve of ruler to seam line at hip.

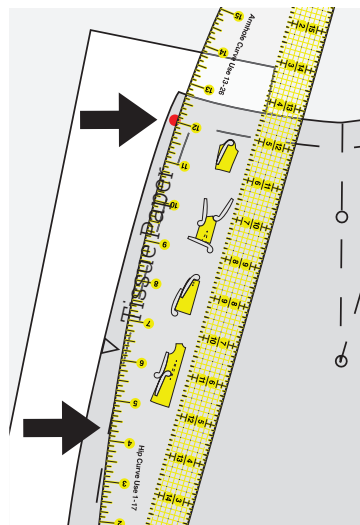

3. Pivot ruler from hip to dot at waist.

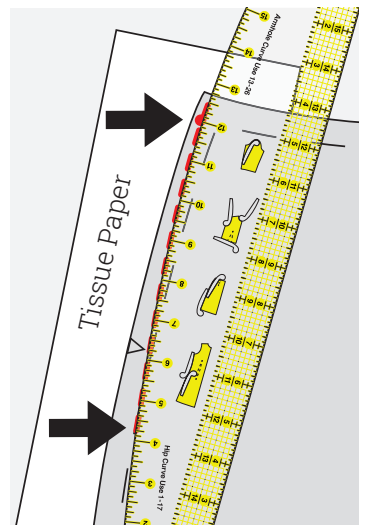

4. Using edge of ruler as a guide, draw in new seam line.



## Increasing or decreasing the waist of a skirt (continued)

Once your new seam line is marked, you must adjust the seam allowance accordingly. Use the grid-marked end of the ruler to measure out the required distance for the seam allowance (5/8", for example). Make multiple dots along the curved hip section (5).

Then turn the ruler and align the curved edge with the new marks (6). Use the ruler as a guide to draw in the new seam allowance (7). If the edge is straight, simply align the correct seam measurement on the long straight edge to the dots and then use the ruler edge as a guide to draw in the new seam allowance.

Again, using the ruler as a guide, continue the waist seam allowance line to the edge of the new side seam allowance (8).

Repeat the process for both the front and back pattern pieces. The side seams must match.

**TIP:** To measure and mark seam allowance, use either the short end of the grid-marked section or the long straight edge. Either way, you must mark, slide, and pivot the ruler for each new measurement.

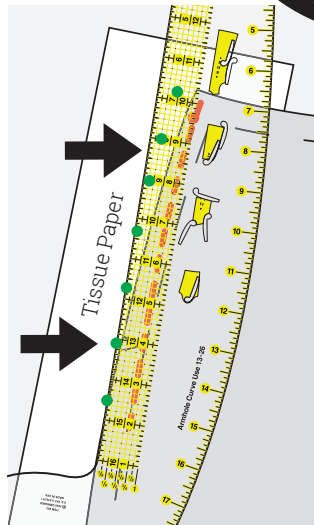

5. Use grid-marked edge of ruler to measure and mark the seam allowance.

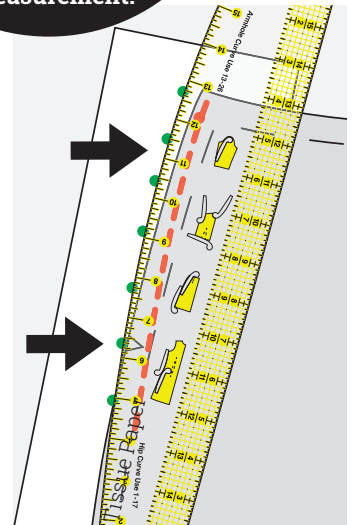

6. Line up the curved edge of the ruler to the dots.

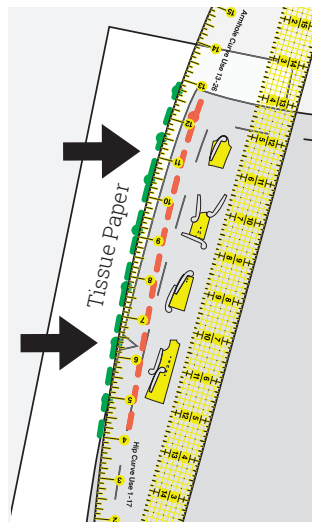

7. Use ruler as a guide to draw the seam allowance line.

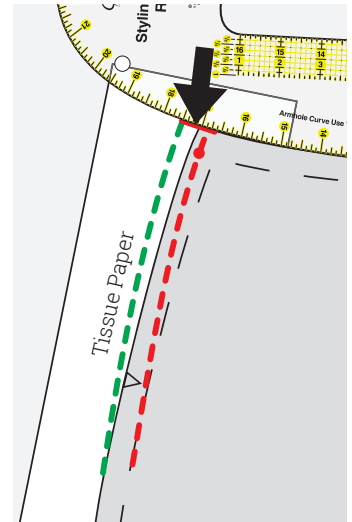

8. Draw the extended waist line.

**NOTE:**

*If the skirt will be attached to a bodice, you must adjust the bodice side seams accordingly. Seams must match up.*



## Increasing or decreasing the hip area of a skirt

Determine the amount by which you plan to change your pattern. If increasing (method shown to the right), tape tissue paper to the full length at the side of the pattern (1). Mark the measured amount with a dot in or out from the seam line of the side seam 7–9" down from the waist (1).

Match the curve of the ruler to the curve of the pattern's side seam line from the waist to the hip area (2). Hold the ruler in place at the waist/side seam intersection, and pivot the ruler to the new dot at the hip area (3).

(Instructions for increasing or decreasing the hip area of a skirt continue on the next page.)

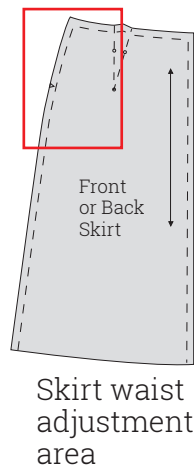

Illustrations show increasing the hip area.

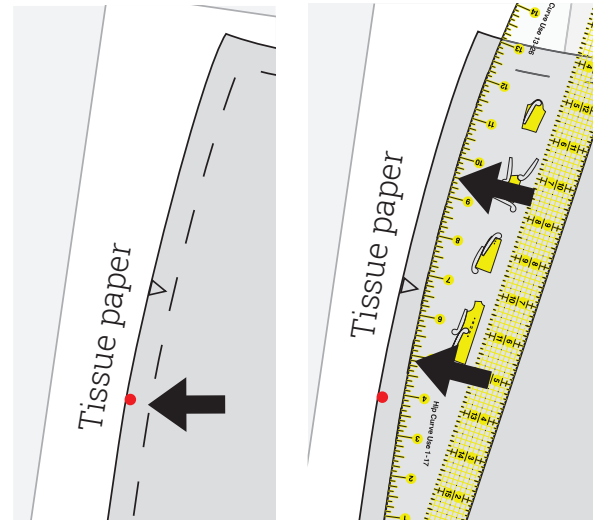

1. Add tissue paper from waist to hem. Mark the adjusted amount out from side seam at hip.
2. Match curve of ruler to seam line at hip.

**Adjustments to the waist and hip are often done to the same pattern. Slide ruler to blend new lines smoothly.**

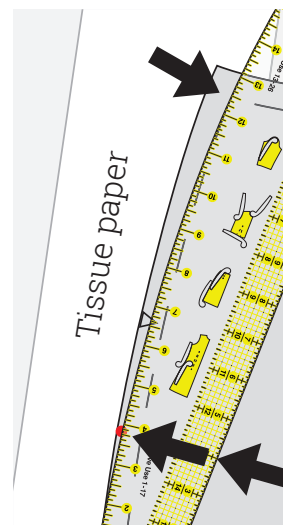

3. Pivot ruler from waist to dot at hip.





## Increasing or decreasing the hip area of a skirt (continued)

Use the ruler as a guide to draw the new line from the waist to the hip dot (4).

Next, use the ruler's straight edge to continue this line from the hip area down to the seam line at the hem (5). You may also choose to continue the added width all the way to the hem edge (6).

(Instructions for increasing or decreasing the hip of a skirt continue on the next page.)

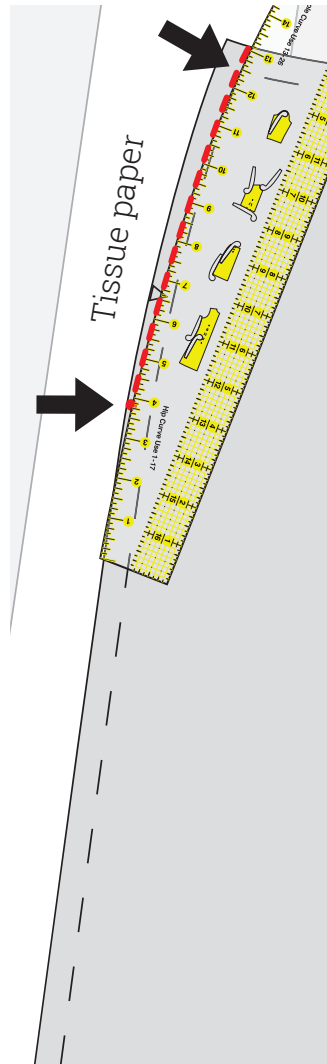

4. Draw new seam line, using ruler as guide.

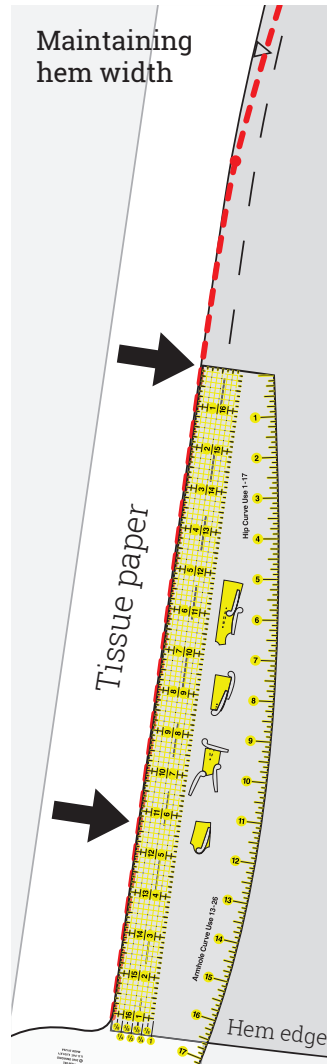

5. To maintain the original seam angle, turn the ruler and align the straight edge of the ruler with the existing edge of the pattern.

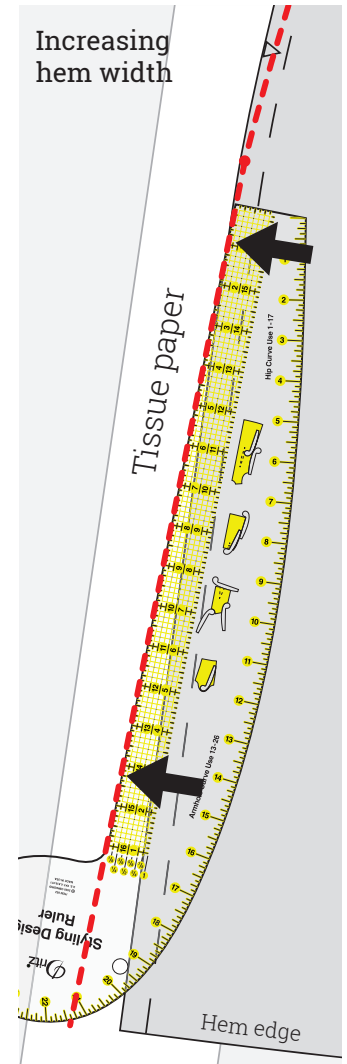

6. To increase the width at the hem, turn the ruler and align the straight edge with the new hip line, continuing the wider angle.



## Increasing or decreasing the hip area of a skirt (continued)

Once your seam line is marked, you must adjust the seam allowance accordingly. To do this, position the grid-marked ruler perpendicular to the edge to measure out the required distance (5/8", for example) and place multiple dots along the curved hip area (7). Or, for the straight part of the side seam, simply align the specified seam measurement on the long straight edge to mark the new seam line (8).

(Instructions for increasing or decreasing the hip area of a skirt continue on the next page.)

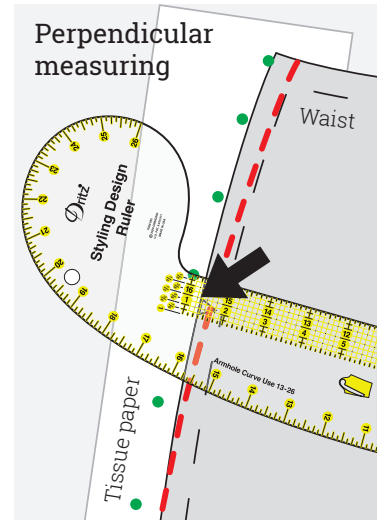
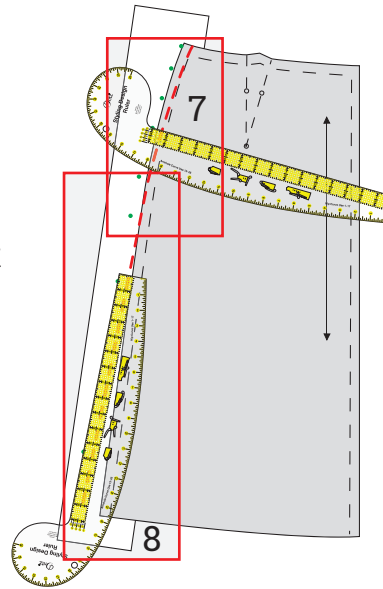

7. Hold the grid-marked straight edge perpendicular to the seam to mark the new seam allowance.

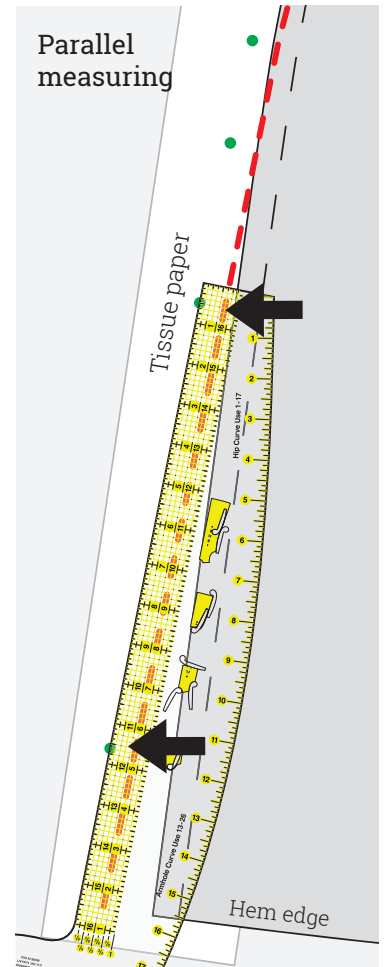

8. Use the long straight edge to measure a parallel line along the lower straight edge of the skirt seam.



## Increasing or decreasing the hip area of a skirt (continued)

Use the curved and straight ruler edges as guides to draw in the new seam allowance (9). Then use the straight edge as a guide to continue the hem line out to the edge of the new seam allowance (10).

Repeat the process for both the front and back pattern pieces. The side seams must match.

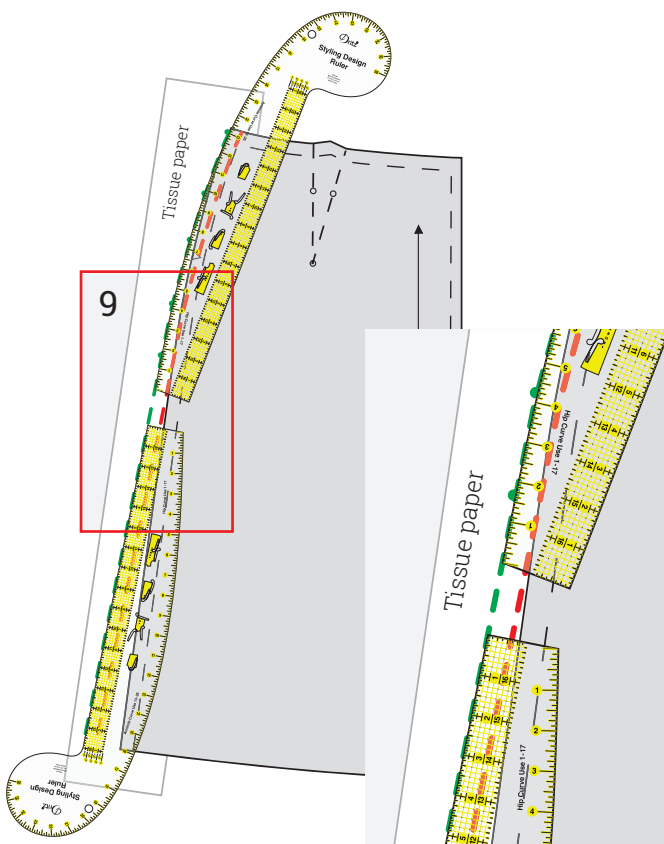

9. Use both the curved and straight edges of the ruler as guides to mark the new line for the seam allowance.

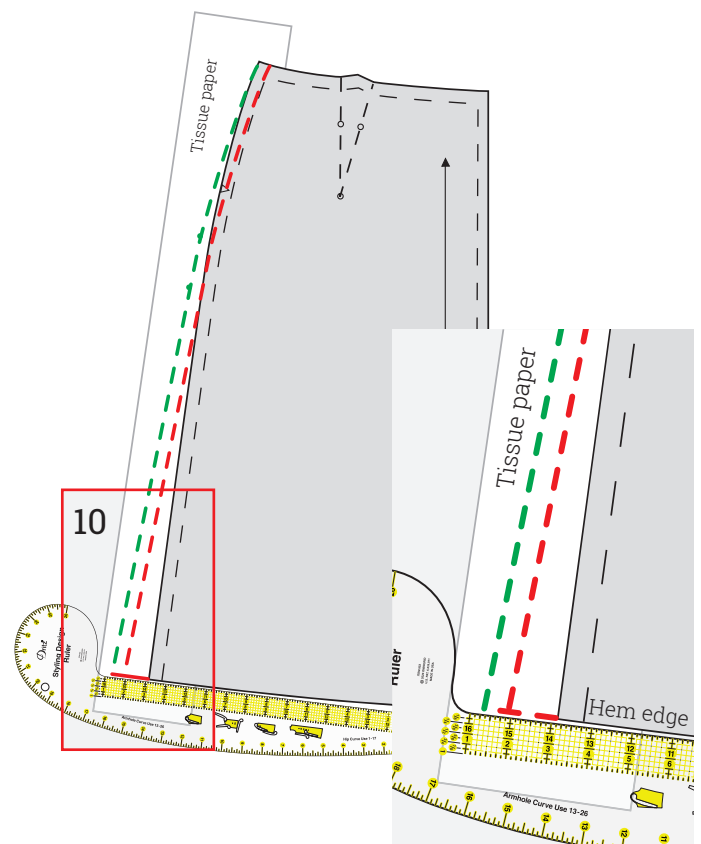

10. Use the straight edge of the ruler as a guide to mark the hem edge of the extended side.



## Reducing the waist of a one-piece dress

Determine the amount by which you plan to change your pattern. Place a dot for the measured amount inside the seam line at the side waist of the pattern piece (1).

The new line will be drawn in two sections and blended. For the top section, place the ruler so it touches both the underarm/side seam intersection and the new dot at the waist (2). Use the ruler as a guide to draw the new line (3).

(Instructions for shaping the waist of a one-piece dress continue on the next page.)

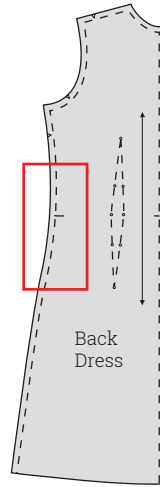

Dress waist adjustment area

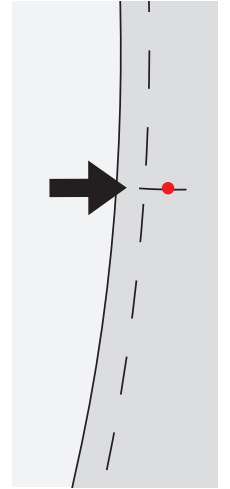

1. Place a dot inside the seam line of the waist to reduce.

**NOTE:** Dress styles vary. You may need to use a different portion of the ruler than shown.

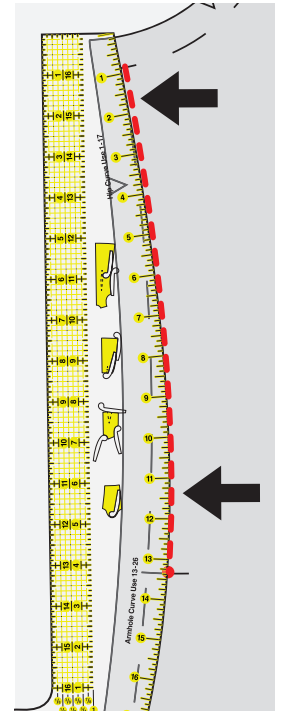
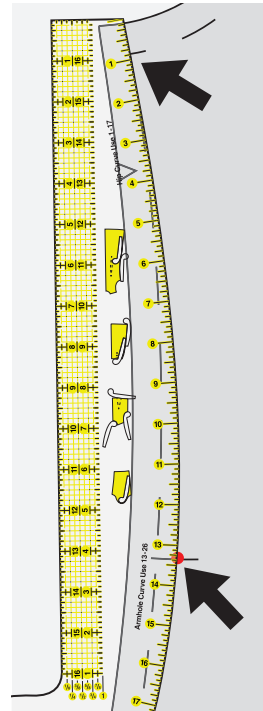

### Top section of seam

2. Align ruler so it touches intersection of underarm/side seam line and new dot at waist.
3. Use the ruler as a guide to draw in the top section of the line.



## Reducing the waist of a one-piece dress (continued)

For the lower section, slide the ruler below the waist so it lines up with the side seam line, touching the line as far down from the waist as possible (4). Hold the ruler in place at the lowest point, and pivot the ruler so it meets the waist dot and the previously drawn new top portion of the line. To blend the line into the hip area, you may need to turn the ruler and slide it down until it touches both the hip seam line and the new line extending down from the waist. Use the ruler as a guide to draw in the lower portion of the line, blending it smoothly (5).

(Instructions for reducing the waist of a one-piece dress continue on the next page.)

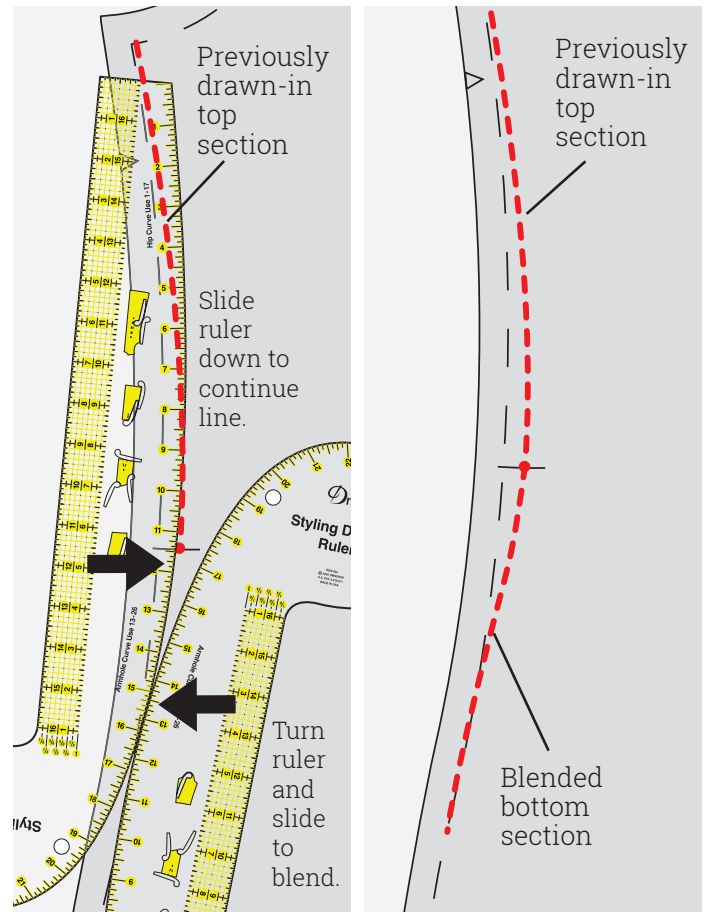

**NOTE: The diagram for step 4 shows two rulers in use. This is to demonstrate how the ruler is turned and moved to draw the line. First the ruler is placed to continue the previously-drawn top section (shown by the top ruler). The bottom ruler shows how it is turned and moved downward to blend the line into the hip area.**

### Lower section of seam

4. Slide ruler down to align with existing hip seam line. Hold ruler there and pivot until it meets new line at waist dot. Turn the ruler as needed to blend line into hip.
5. Use ruler as a guide to draw in the continued new side seam line.



## Reducing the waist of a one-piece dress (continued)

Once your seam line is marked, you must adjust the seam allowance accordingly. To do this, place the grid-marked ruler perpendicular to the edge. Measure and mark the required distance for the seam allowance (5/8", for example) with multiple dots along the curved hip and waist sections (6). Then use the curved ruler edge as a guide to draw in the new seam allowance (7).

Repeat the process for both the front and back pattern pieces. The side seams must match.

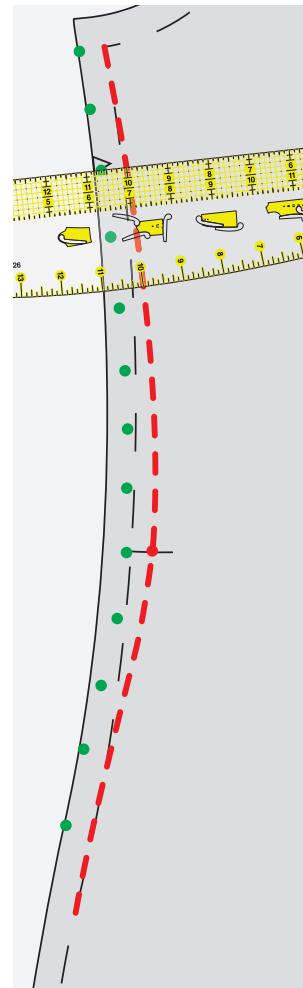
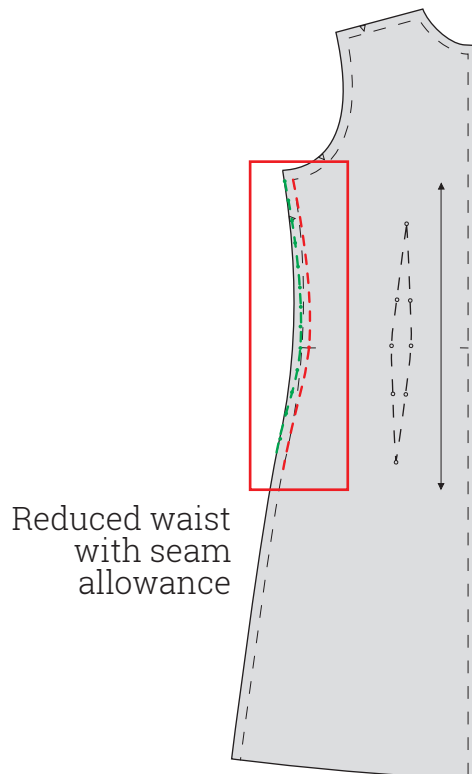

6. Use grid-marked edge of ruler to measure out for the adjusted seam allowance and make multiple dots.

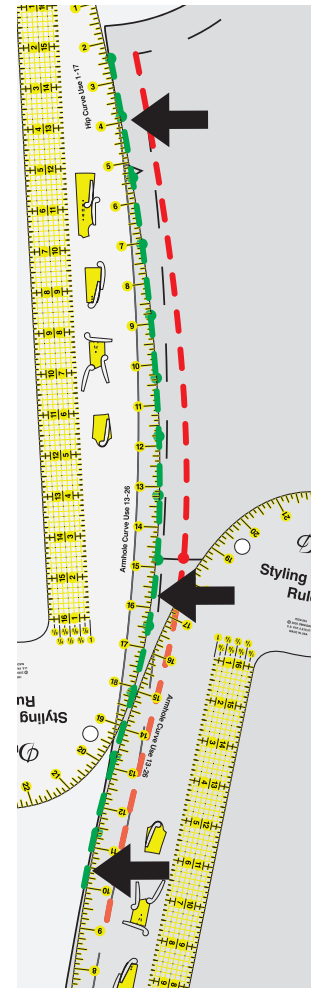

7. Use ruler as a guide to draw in the new seam allowance.



## Enlarging the waist of a one-piece dress

Determine the amount that you plan to change your pattern. Make a dot for the measured amount outside the seam line at the side waist of the pattern piece (1). To allow room for the increased pattern width, tape tissue paper to the pattern from the underarm seam to beyond the hip (1).

The new line is drawn in two sections and blended. For the top section, place the ruler so it touches both the underarm/side seam intersection and the new dot at the waist (2). Use the ruler as a guide to draw the new line (3).

(Instructions for enlarging the waist of a one-piece dress continue on the next page.)

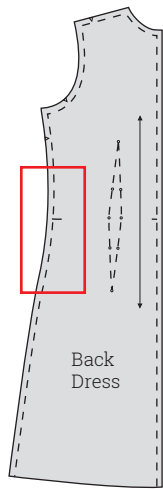

Dress waist adjustment area

Illustrations show enlarging a waist.

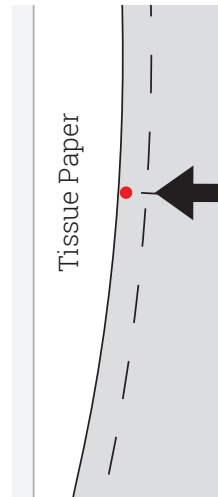

1. Place a dot outside the seam line of the waist to enlarge.

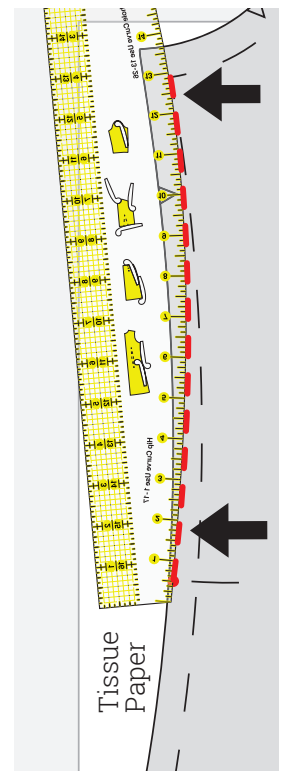
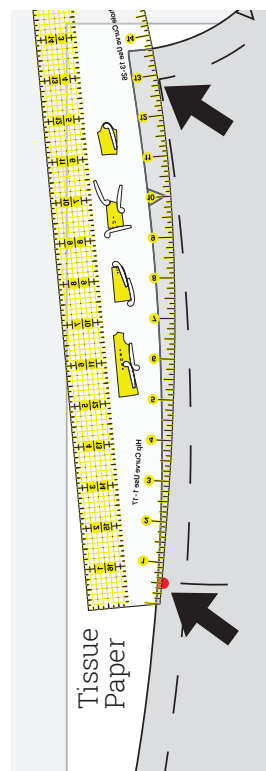

### Top section of seam

2. Place ruler so it touches the side/underarm seam intersection and the new dot at the waist.
3. Use the ruler as a guide to draw in the new seam line.

**NOTE:** Dress styles vary. The section of ruler used may differ from those shown.



## Enlarging the waist of a one-piece dress (continued)

For the lower section, slide the ruler below the waist so it lines up with the original side seam line, touching the line as far down from the waist as possible. Hold the ruler in place at the lowest point, and pivot the ruler so it meets the waist dot (4). Draw in this portion of the line (5).

You may need to slide and adjust the ruler to blend the line.

(Instructions for enlarging the waist of a one-piece dress continue on the next page.)

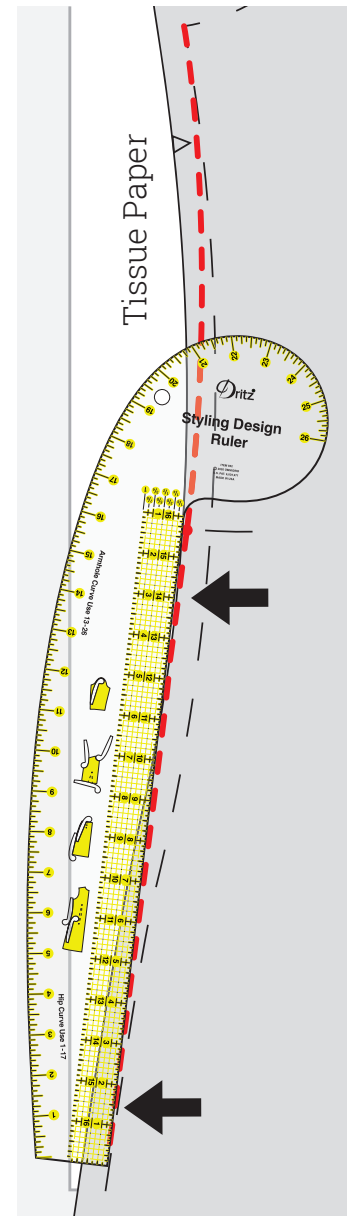
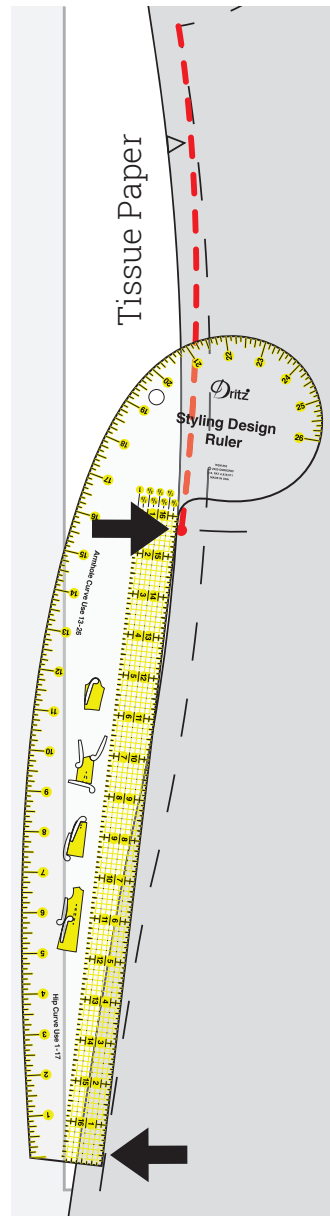

Lower section of seam

4. Slide the ruler down until it touches the seam line at the hip; hold the ruler at the hip and pivot the ruler until it touches the dot at the waist.
5. Use the ruler as a guide to draw in the new seam line.





## Enlarging the waist of a one-piece dress (continued)

Once your seam line is marked, you must adjust the seam allowance accordingly. Place the grid-marked ruler perpendicular to the edge. Measure and mark the required distance for the seam allowance (5/8", for example) from the new seam line with multiple dots along the curved hip and waist sections (6). Use both the curved and straight ruler edges as guides to draw in the new seam allowance (7).

Repeat the process for both the front and back pattern pieces. The side seams must match.

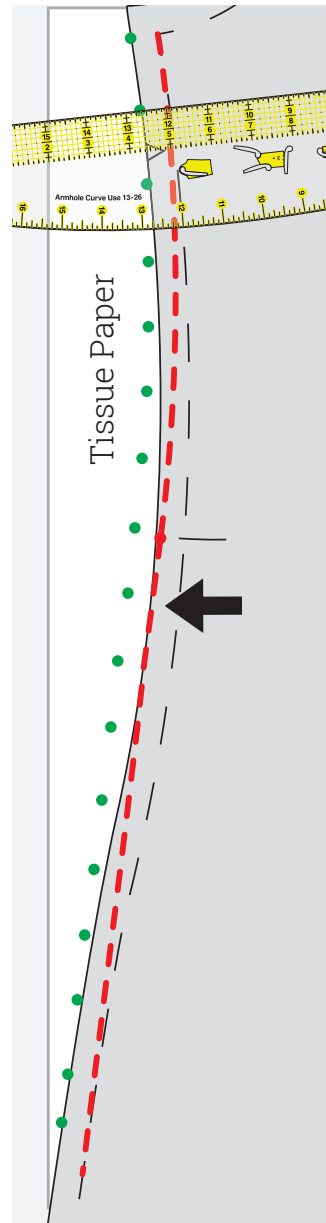

6. Slide the ruler down until it touches the seam line at the hip; hold the ruler at the hip and pivot the ruler until it touches the dot at the waist.

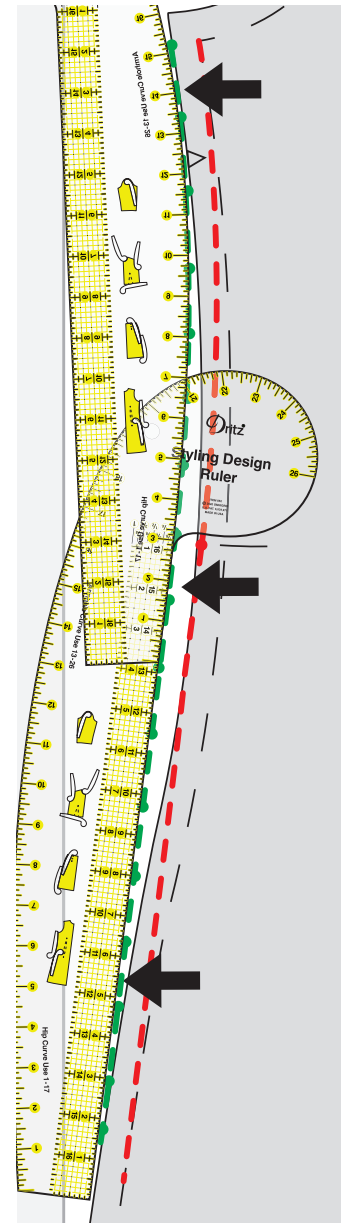

7. Use the ruler as a guide to draw in the new seam line.



Useful tips and ideas

**Cutting:**

The Styling Design Ruler is made of 1/8" thick, laser-cut acrylic. As such, it offers an edge that is perfect for rotary cutting. While the fabric for most garments is cut with scissors, there are always projects that include longer edges that suggest the option of rotary cutting. It saves time! To use the ruler with a rotary cutter, always push down firmly on the ruler with your non-cutting hand. Hold the cutter so the blade is perpendicular to the cutting surface and push the cutter away from you. A cutting mat is a must (1).

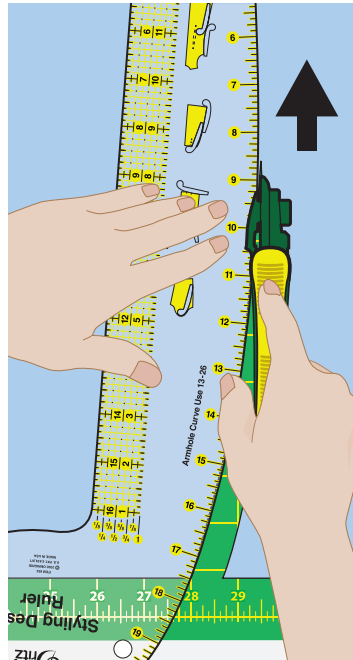

1. Press down firmly on ruler; hold cutter perpendicular to mat with blade against ruler edge. Push cutter away from you to cut.

**Combine rulers:**

There are three Dritz® fashion rulers—the Styling Design Ruler, the 24" Hip Curve Ruler, and the 12" Curve Ruler. Each has a distinctly different shape and unique features. While each works independently for special techniques, using more than one to complete a project makes perfect sense. Not all lines are created equal. Having all three rulers increases your options for drawing smooth, creative lines. Start by drawing one section with one ruler and complete the line with the another, sliding to create a smoothly transitioned line (2). So easy and convenient!

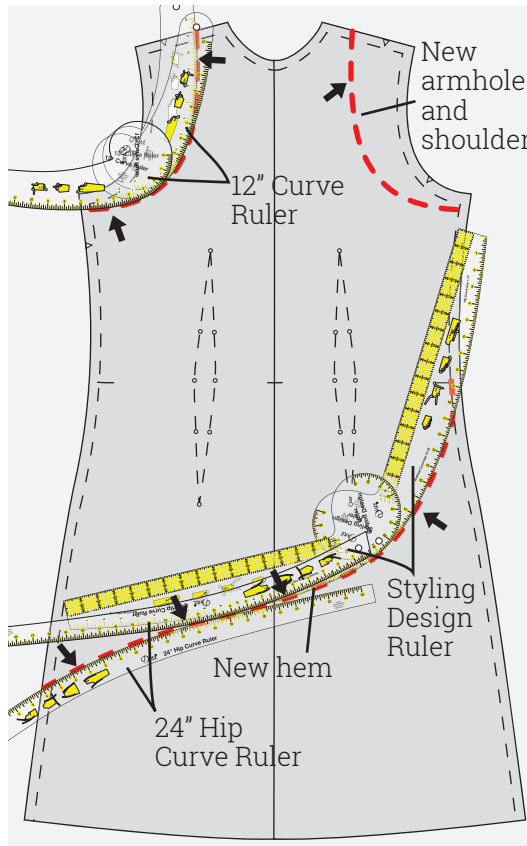

2. Use multiple rulers to draw creative style lines. This sample uses all three to convert a dress into an asymmetric halter tunic.

**See our other ruler tutorials:**

“How to Use a 24" Hip Curve Ruler” and “How to Use a 12" Curve Ruler”

