

ITEM #	OPENING ANGLE	CRANK	DEPTH ADJUSTMENT	CONNECTION TYPE
700.0535	110	0	CAM	NO DOWELS
700.0181	110	0	CAM	PRESS-IN DOWELS
700.L110	110	0	CAM	LEVER TOP

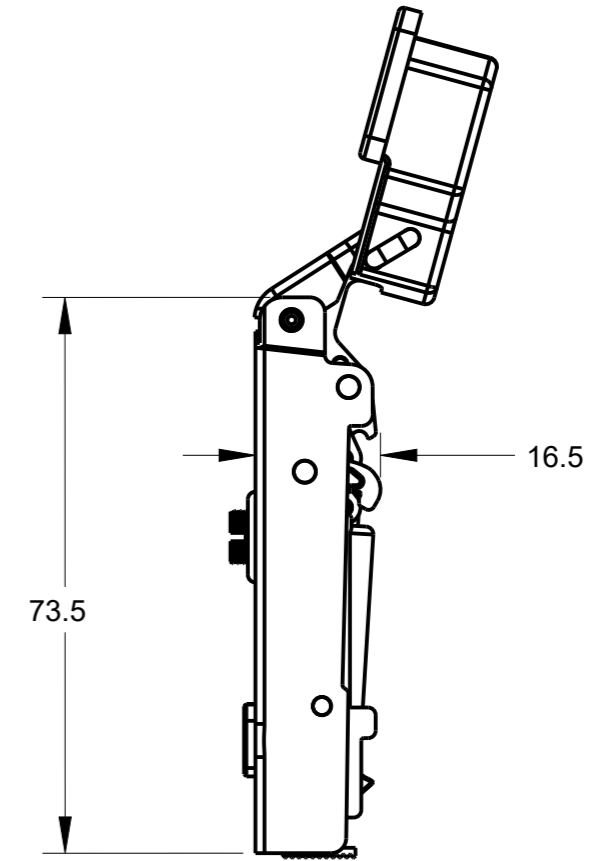
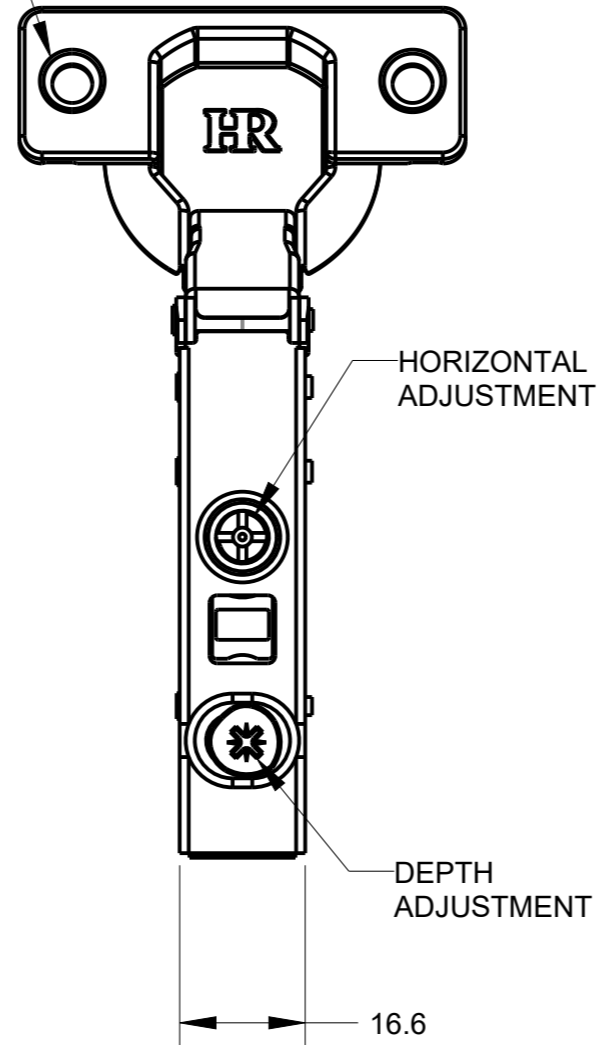
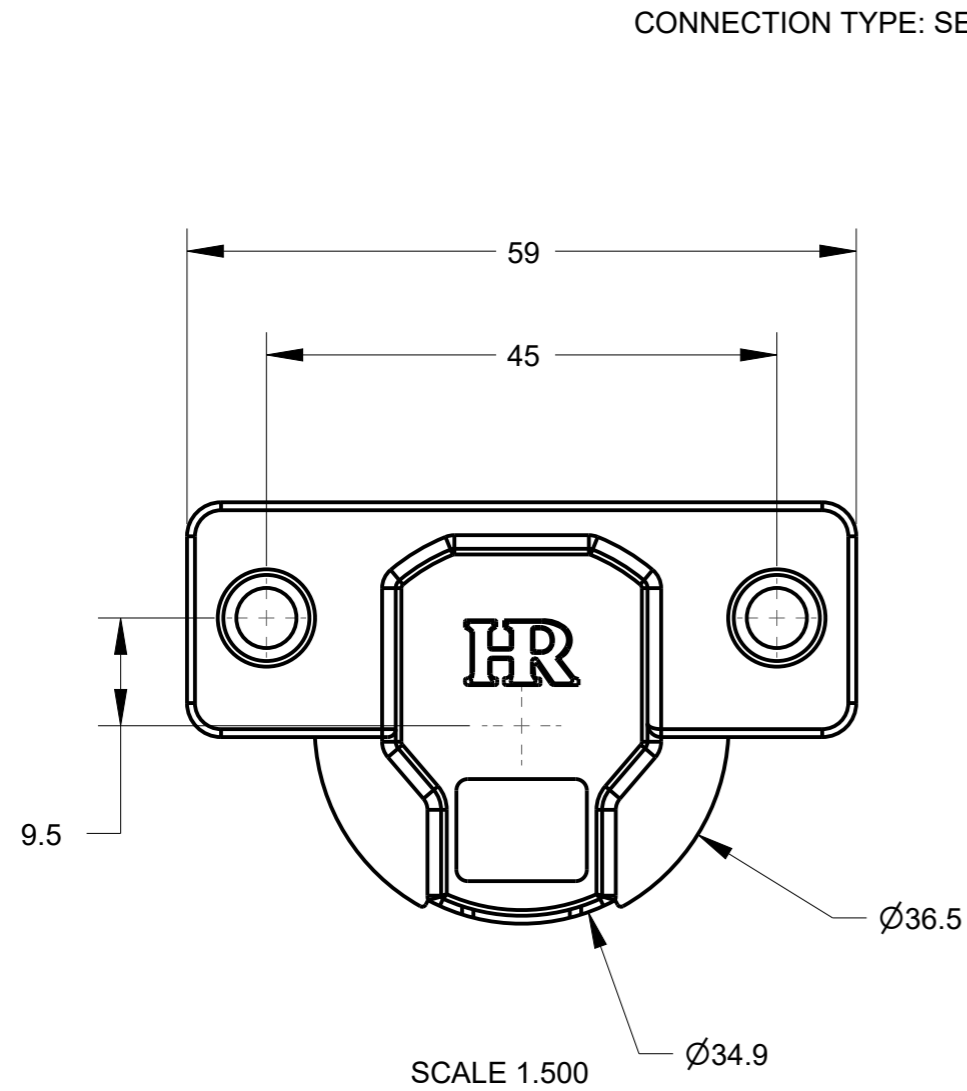

hardware resources

HARDWARE RESOURCES RESERVES THE RIGHT TO CHANGE SPECIFICATIONS WITHOUT NOTICE. IN CASE OF A DISCREPANCY, ACTUAL PART GEOMETRY SUPERSEDES THIS DOCUMENT.

THE INFORMATION CONTAINED WITHIN THIS DRAWING IS THE SOLE PROPERTY OF HARDWARE RESOURCES INC. ANY REPRODUCTION IN PART OR WHOLE WITHOUT WRITTEN PERMISSION OF HARDWARE RESOURCES INC. IS PROHIBITED.

DOCUMENT STATUS **Released**

UNLESS OTHERWISE SPECIFIED DIMENSIONS ARE IN MILLIMETERS (MM)

MATERIAL
STEEL

FINISH
ZINC

THIRD ANGLE PROJECTION

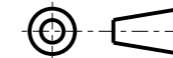

DATE

07SEP2023

DESCRIPTION

HINGE, 700, 0-CRANK, CAM, 110 DEG

DRAWING NUMBER
700_0535_0181_L110

REV
A

SIZE
A3

SCALE
1.000

SHEET
1 / 1