

SECTION A-A

Item	Finish
VMIR-METR-33BG	Brushed Gold
VMIR-METR-33MB	Matte Black
VMIR-METR-33SBZ	Satin Bronze
VMIR-METR-33SN	Satin Nickel

	ITEM#: VMIR-METR-33		MATERIAL:	
	FINISH:		WEIGHT:	
<p>PROPRIETARY AND CONFIDENTIAL</p> <p>THE INFORMATION CONTAINED IN THIS DRAWING IS THE SOLE PROPERTY OF HARDWARE RESOURCES INC. ANY REPRODUCTION IN PART OR AS A WHOLE WITHOUT THE WRITTEN PERMISSION OF HARDWARE RESOURCES INC. IS PROHIBITED.</p> <p>DO NOT SCALE DRAWING</p>	UNITS:		DRAWN BY: <i>Hugo.cai</i>	
	TOLERANCE UNLESS OTHERWISE SPECIFIED:		DATE: Feb-23-23	
	SIZE:		APPROVED BY:	
	SHEET:		RELEASE LEVEL:	
<p>PROJECTION</p>		DATE:		REVISION:

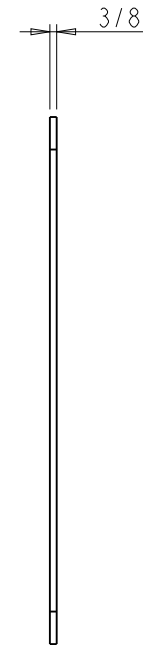
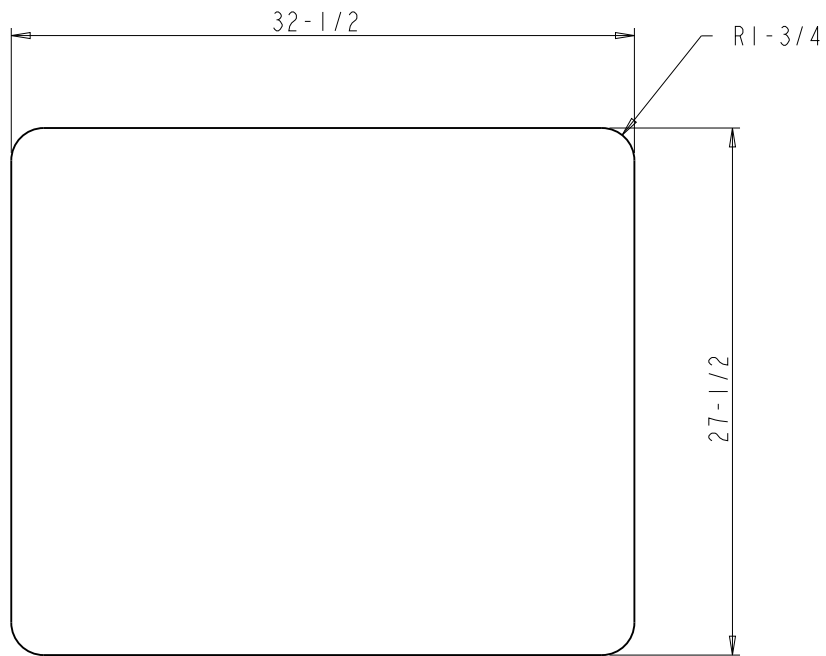

Note:

Material: MDF

	ITEM#: VMIR-METR-33-BACK-BOARD		MATERIAL:	
	FINISH:		WEIGHT: 9	
PROPRIETARY AND CONFIDENTIAL THE INFORMATION CONTAINED IN THIS DRAWING IS THE SOLE PROPERTY OF HARDWARE RESOURCES INC. ANY REPRODUCTION IN PART OR AS A WHOLE WITHOUT THE WRITTEN PERMISSION OF HARDWARE RESOURCES INC. IS PROHIBITED.	TOLERANCE UNLESS OTHERWISE SPECIFIED:		UNITS:	DRAWN BY:
	X ±0.20		SIZE:	APPROVED BY:
	X.X ±0.10			
	X.XX ±0.05		RELEASE LEVEL:	
ANGULAR: ±0.5°		SHEET:		REVISION:
DO NOT SCALE DRAWING				



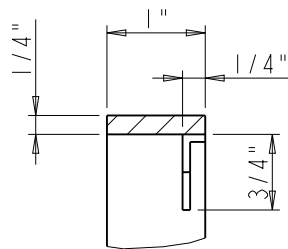
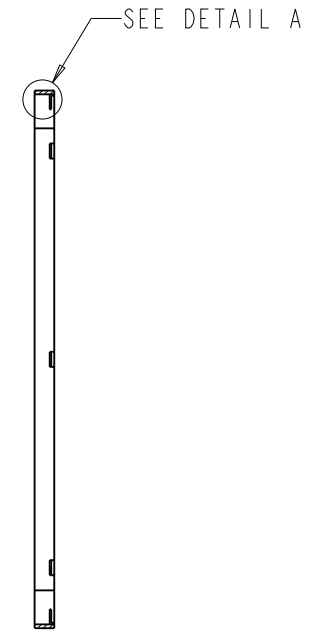
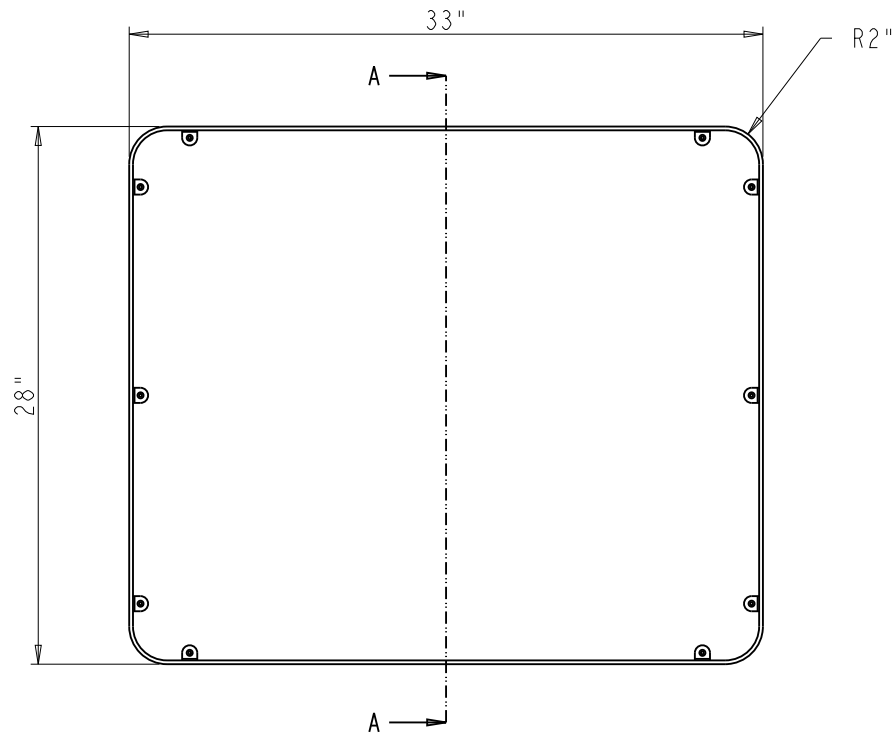



DETAIL A
SCALE 1:2

NOTE:
MATERIAL: Iron

	ITEM#: VMIR-METR-33-FRAME		MATERIAL:	
	FINISH:		WEIGHT:	
<p>PROPRIETARY AND CONFIDENTIAL</p> <p>THE INFORMATION CONTAINED IN THIS DRAWING IS THE SOLE PROPERTY OF HARDWARE RESOURCES INC. ANY REPRODUCTION IN PART OR AS A WHOLE WITHOUT THE WRITTEN PERMISSION OF HARDWARE RESOURCES INC. IS PROHIBITED.</p>	TOLERANCE UNLESS OTHERWISE SPECIFIED:		UNITS:	DATE:
	X ±0.20 X.X ±0.10 X.XX ±0.05 ANGULAR: ±0.5°		DRAWN BY:	Feb-24-23
	DO NOT SCALE DRAWING		APPROVED BY:	DATE:
			RELEASE LEVEL:	REVISION:

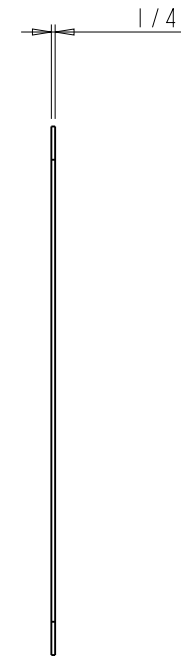
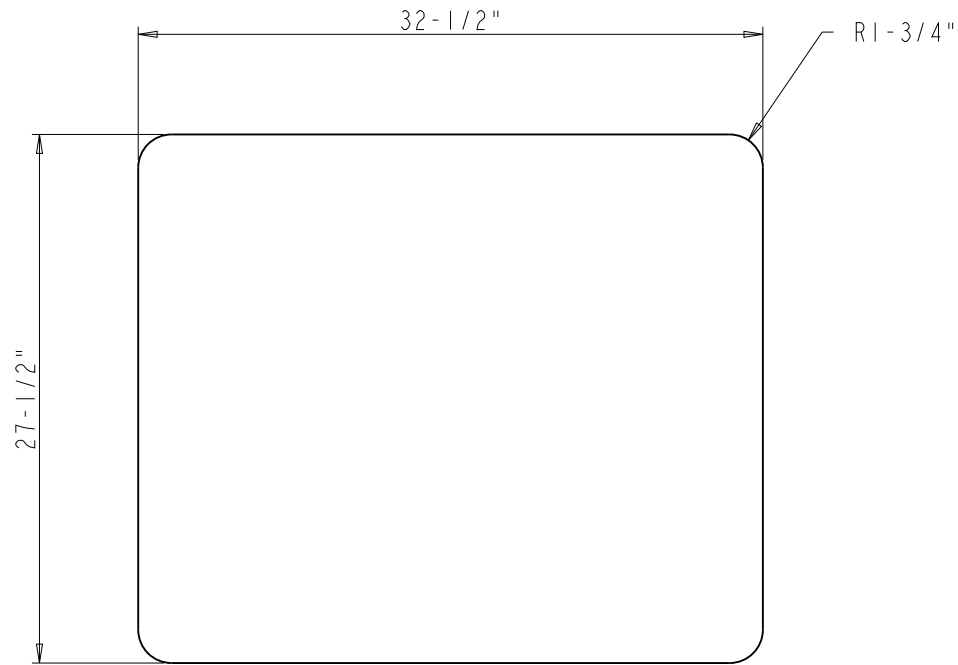



	ITEM#: VMIR-METR-33-MIRROR		MATERIAL:		
	FINISH:		WEIGHT:		
<p>PROPRIETARY AND CONFIDENTIAL</p> <p>THE INFORMATION CONTAINED IN THIS DRAWING IS THE SOLE PROPERTY OF HARDWARE RESOURCES INC. ANY REPRODUCTION IN PART OR AS A WHOLE WITHOUT THE WRITTEN PERMISSION OF HARDWARE RESOURCES INC. IS PROHIBITED.</p>	<p>TOLERANCE UNLESS OTHERWISE SPECIFIED:</p> <p>X ±0.20</p> <p>X.X ±0.10</p> <p>X.XX ±0.05</p> <p>ANGULAR: ±0.5°</p>		<p>UNITS:</p>	<p>DRAWN BY:</p> <p><i>Hugo.cai</i></p>	<p>DATE:</p> <p>Feb-24-23</p>
	DO NOT SCALE DRAWING		<p>SIZE:</p>	<p>APPROVED BY:</p>	<p>DATE:</p>
			<p>SHEET:</p>	<p>RELEASE LEVEL:</p>	<p>REVISION:</p>
			<p>PROJECTION</p> 		<p>9</p>

SEE DETAIL A 

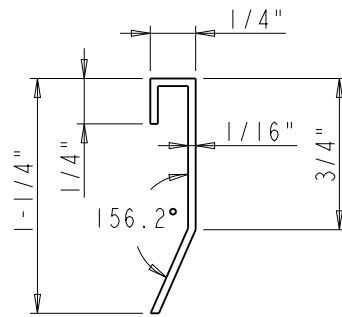
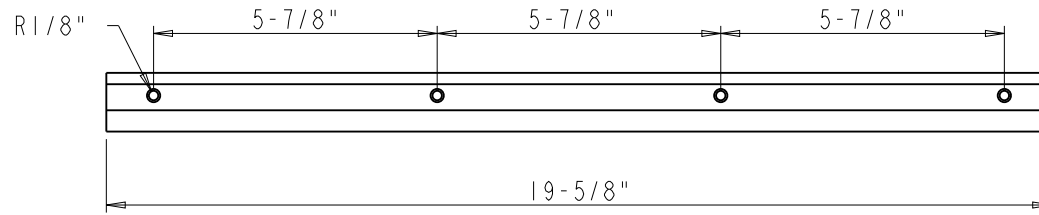

DETAIL A
SCALE 1:1

Note:

Material: Iron

 PROPRIETARY AND CONFIDENTIAL THE INFORMATION CONTAINED IN THIS DRAWING IS THE SOLE PROPERTY OF HARDWARE RESOURCES INC. ANY REPRODUCTION IN PART OR AS A WHOLE WITHOUT THE WRITTEN PERMISSION OF HARDWARE RESOURCES INC. IS PROHIBITED.	ITEM#: VMIR-METC-30-BRACKET		MATERIAL:		
	FINISH:		WEIGHT: 9		
	TOLERANCE UNLESS OTHERWISE SPECIFIED: X ±0.20 X.X ±0.10 X.XX ±0.05 ANGULAR: ±0.5°		UNITS:	DRAWN BY: <i>Hugo.cai</i>	DATE: Feb-23-23
	DO NOT SCALE DRAWING		SIZE:	APPROVED BY:	DATE:
		SHEET:	RELEASE LEVEL:	REVISION:	