

babyletto

lolly
.....

M9060



parts
not to scale

piezas
no a escala

pièces
non dessinées à l'échelle

A

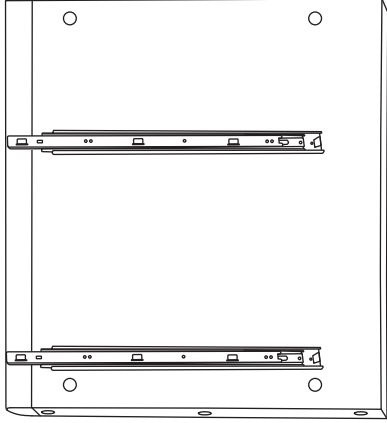

B

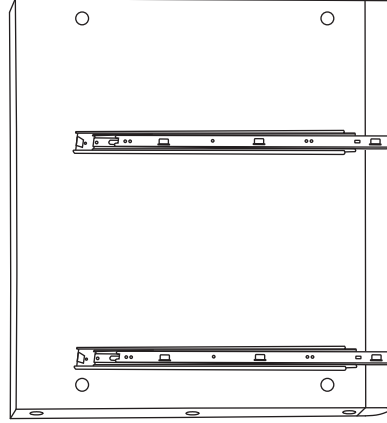

C

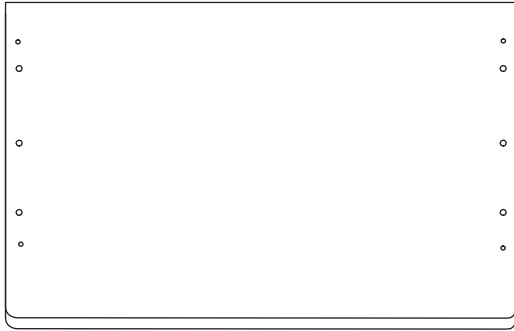

D

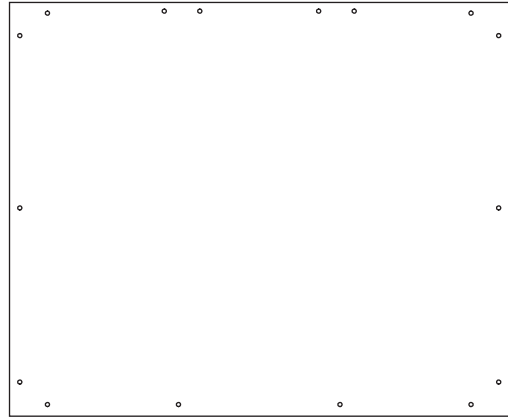

E

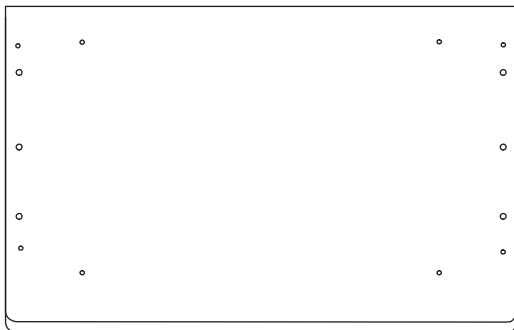

F

x4



hardware
actual size

herraje
tamaño real

matériel
taille actuelle

H1

x4

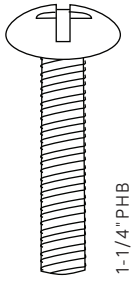

H2

x16

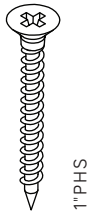

H3

x12

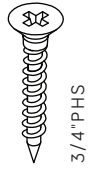

H4

x20



H5

x8

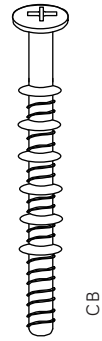

H6

x8



H7

x8

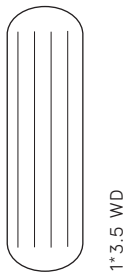

H8

x12



H9

x4



H10

x2

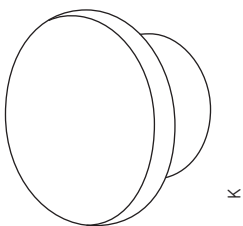

H11

x2

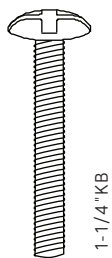

assembly
instructions

instrucciones
de ensamblaje

instructions
de montage

1

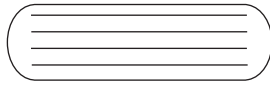

H7
x8

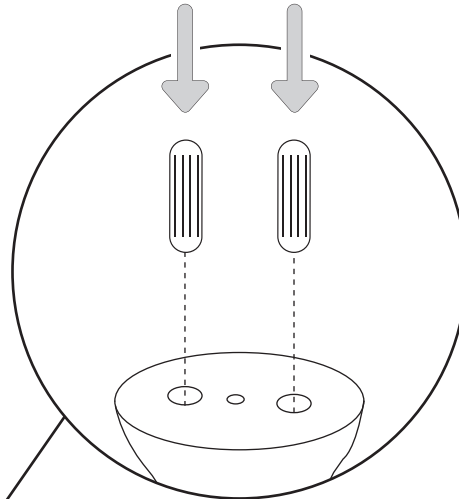

X4

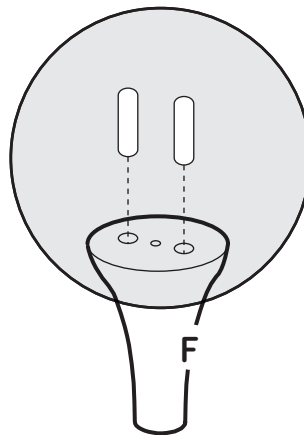
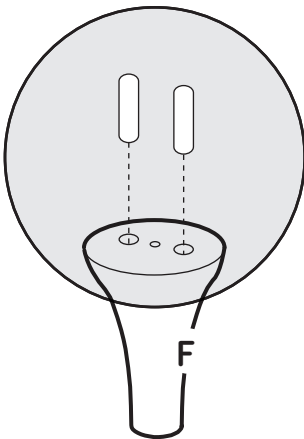
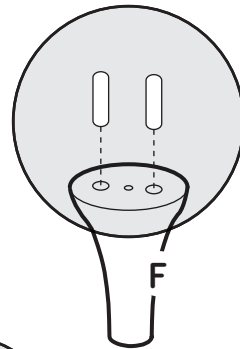
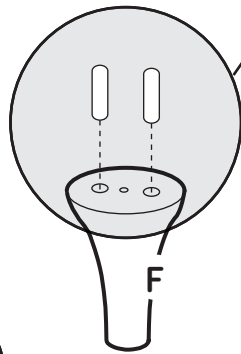

2

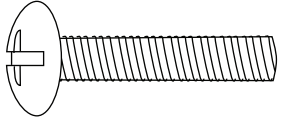

H1
x4

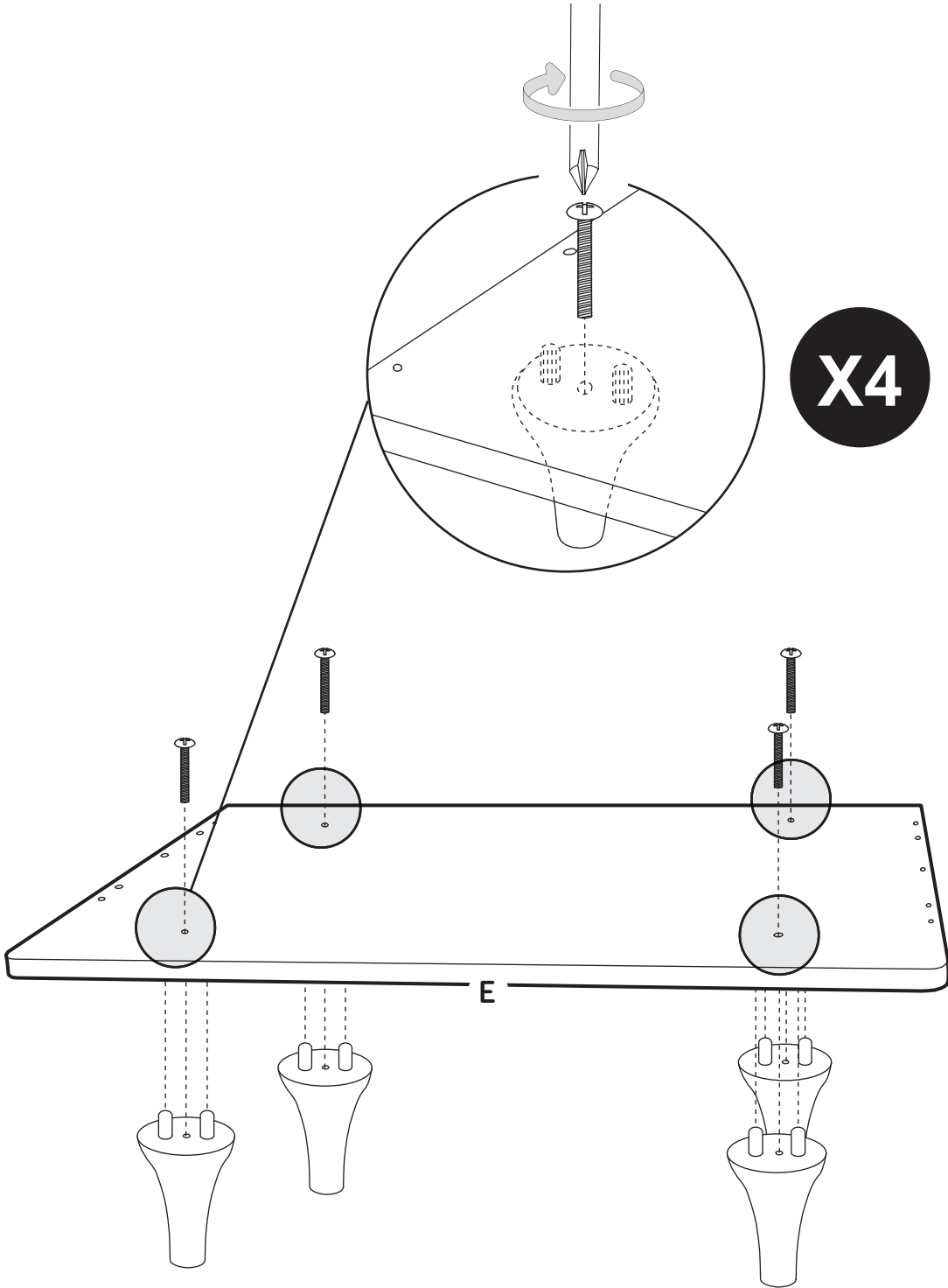

3



X4

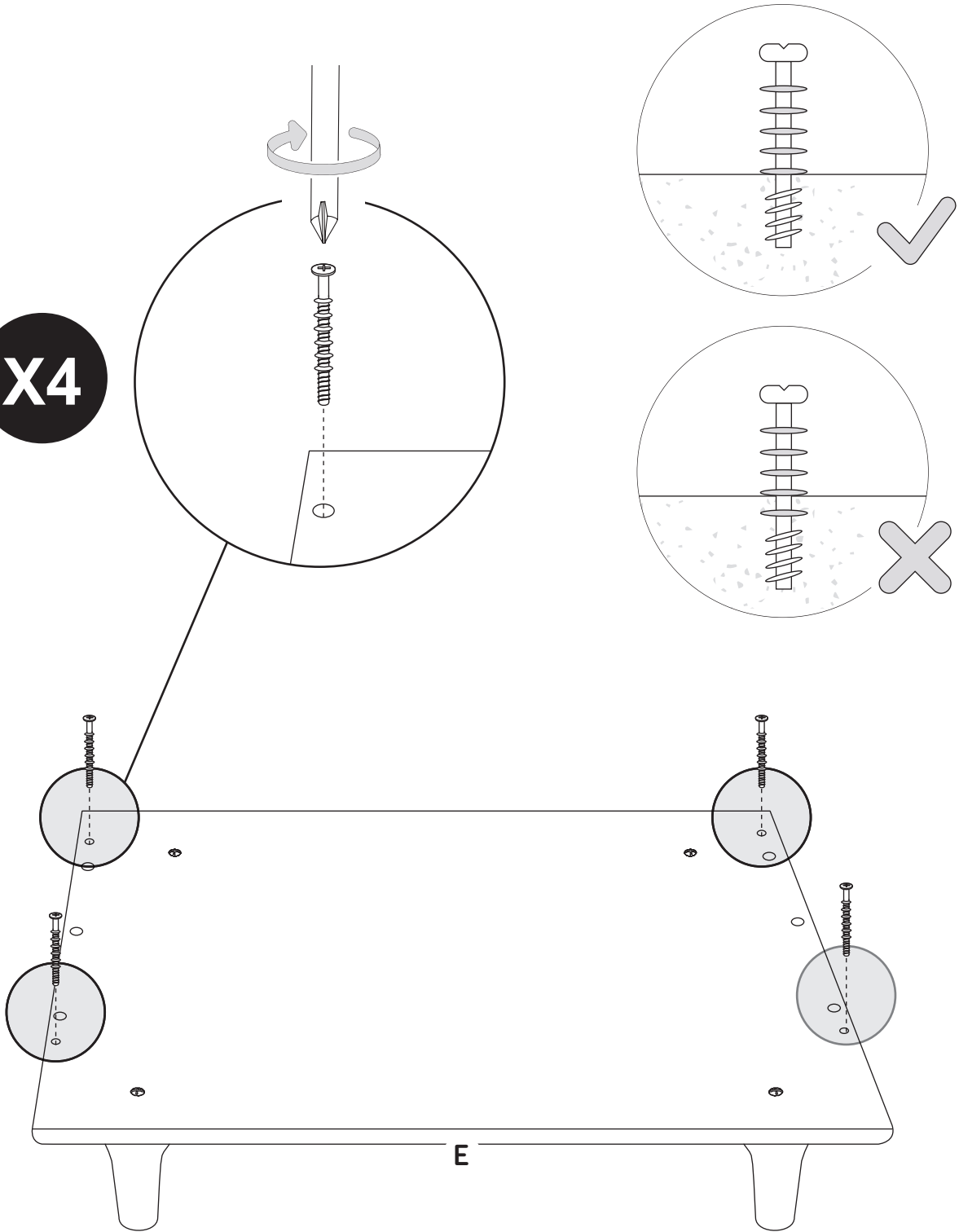

4

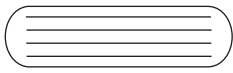

H8
x6

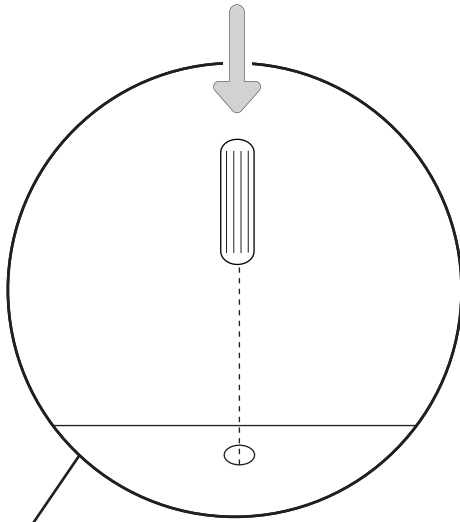

X6

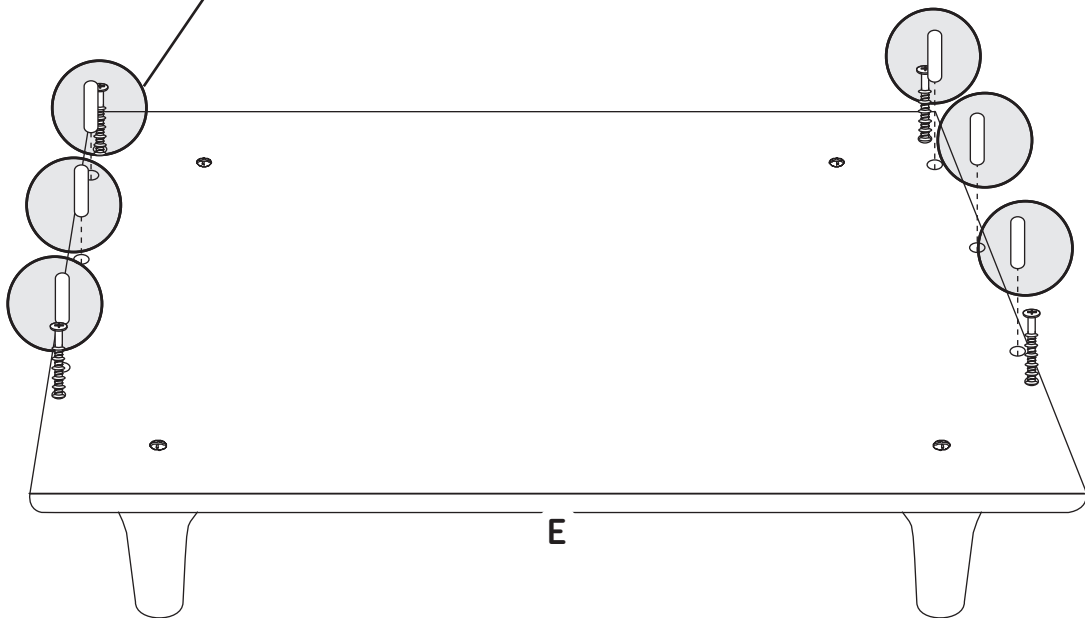

E

5



H6
x2

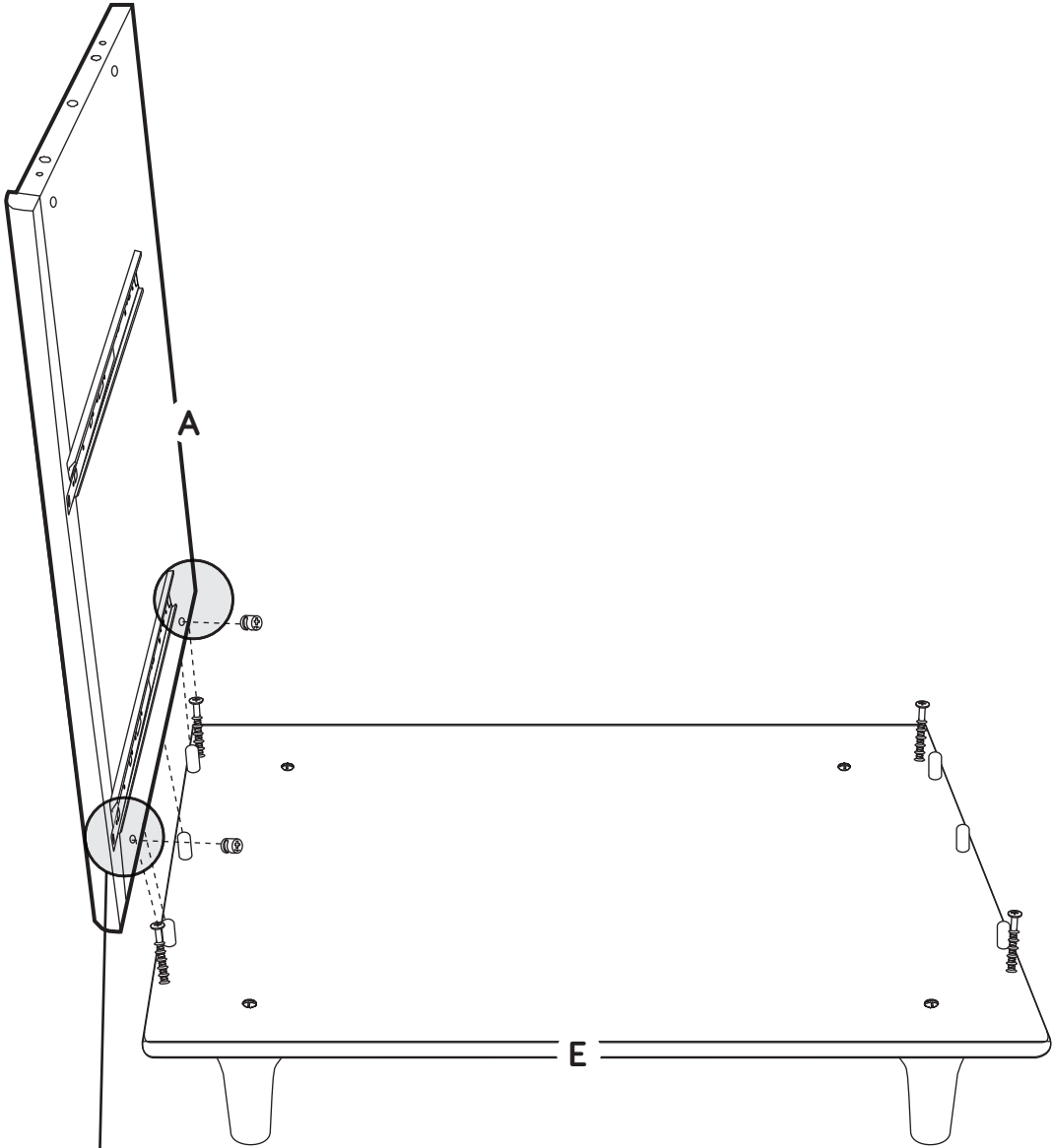

X2

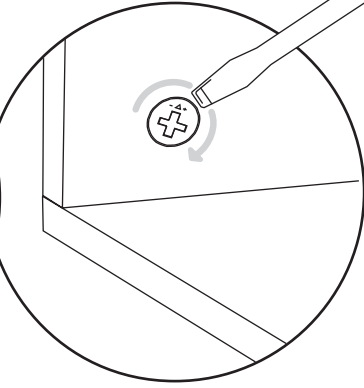
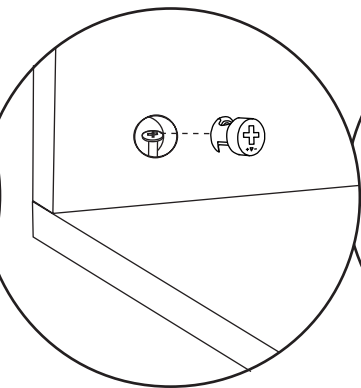
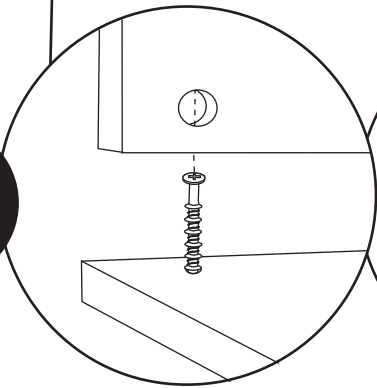

6

H6
x2

X2

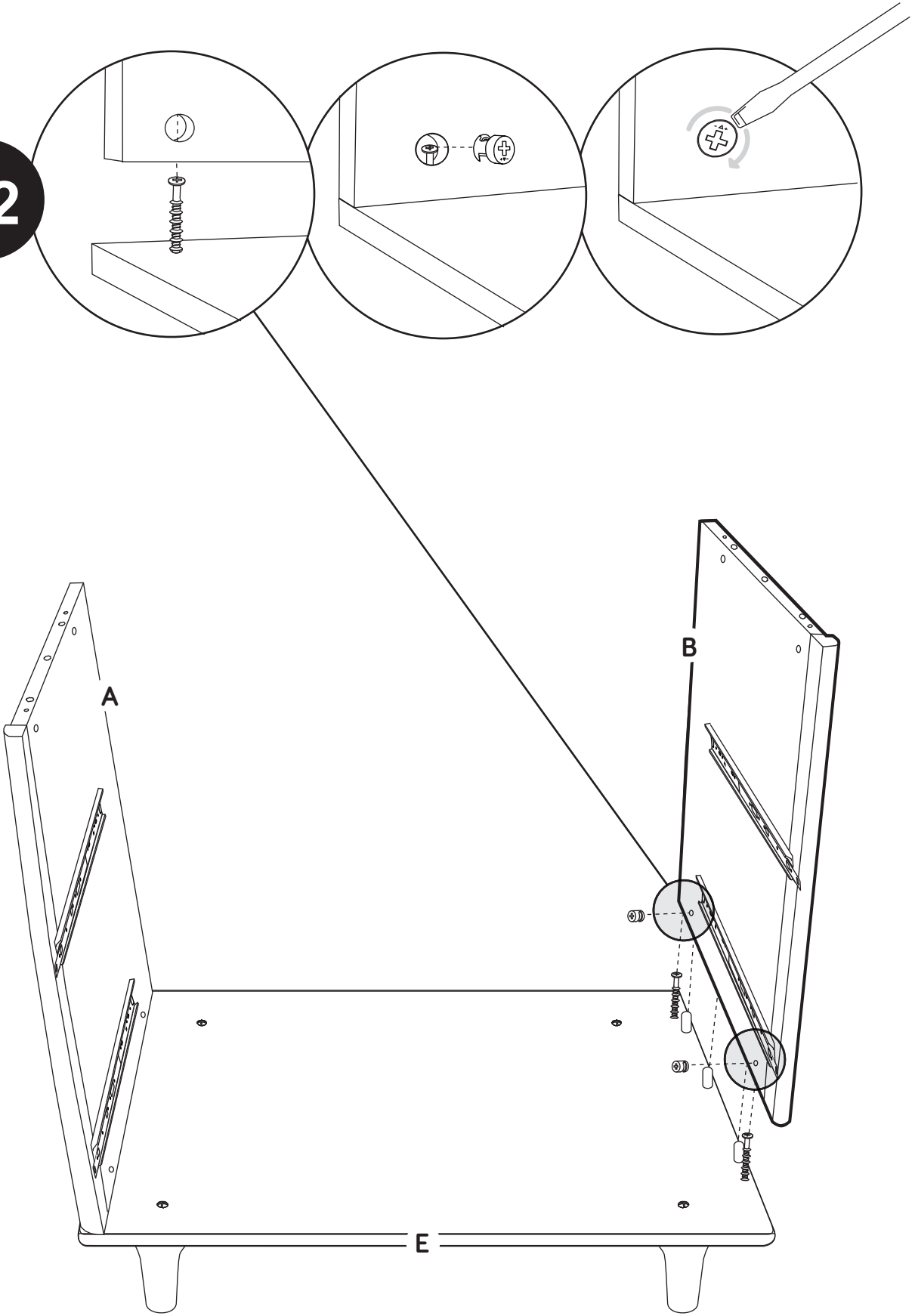

7



H5
x4

X4

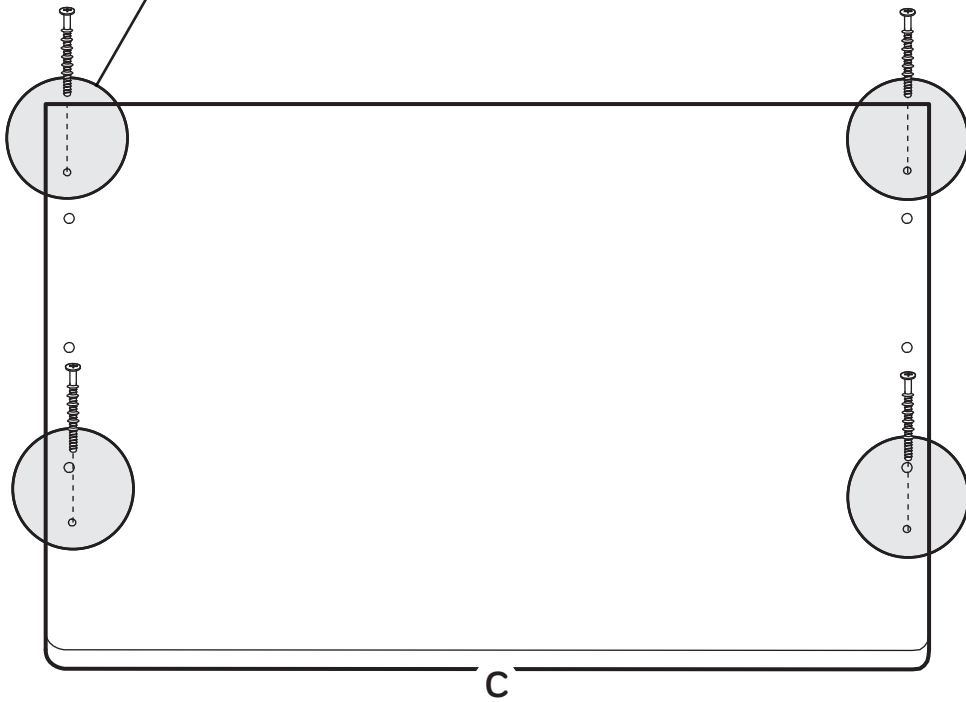
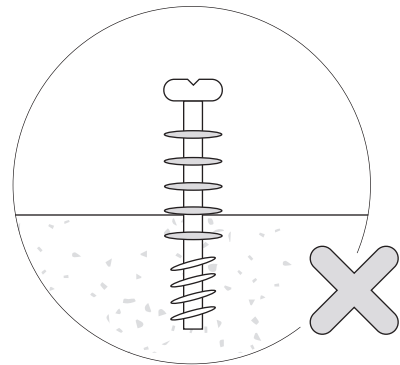
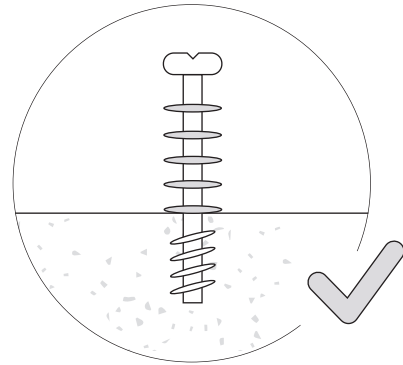
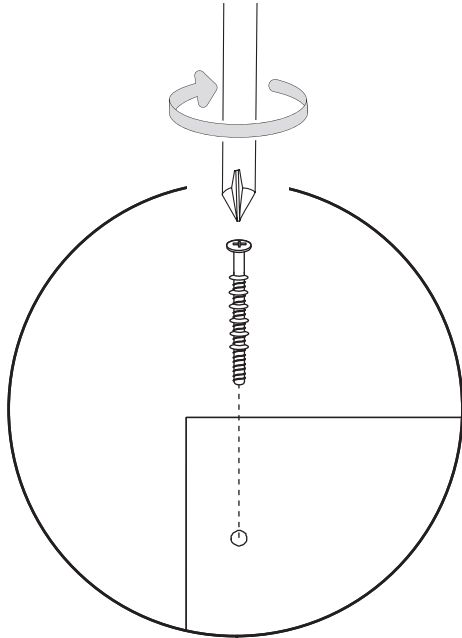

8

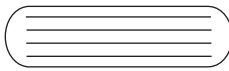

H8
x6

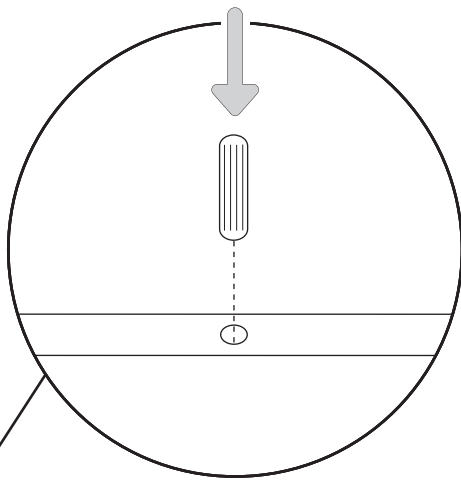

X6

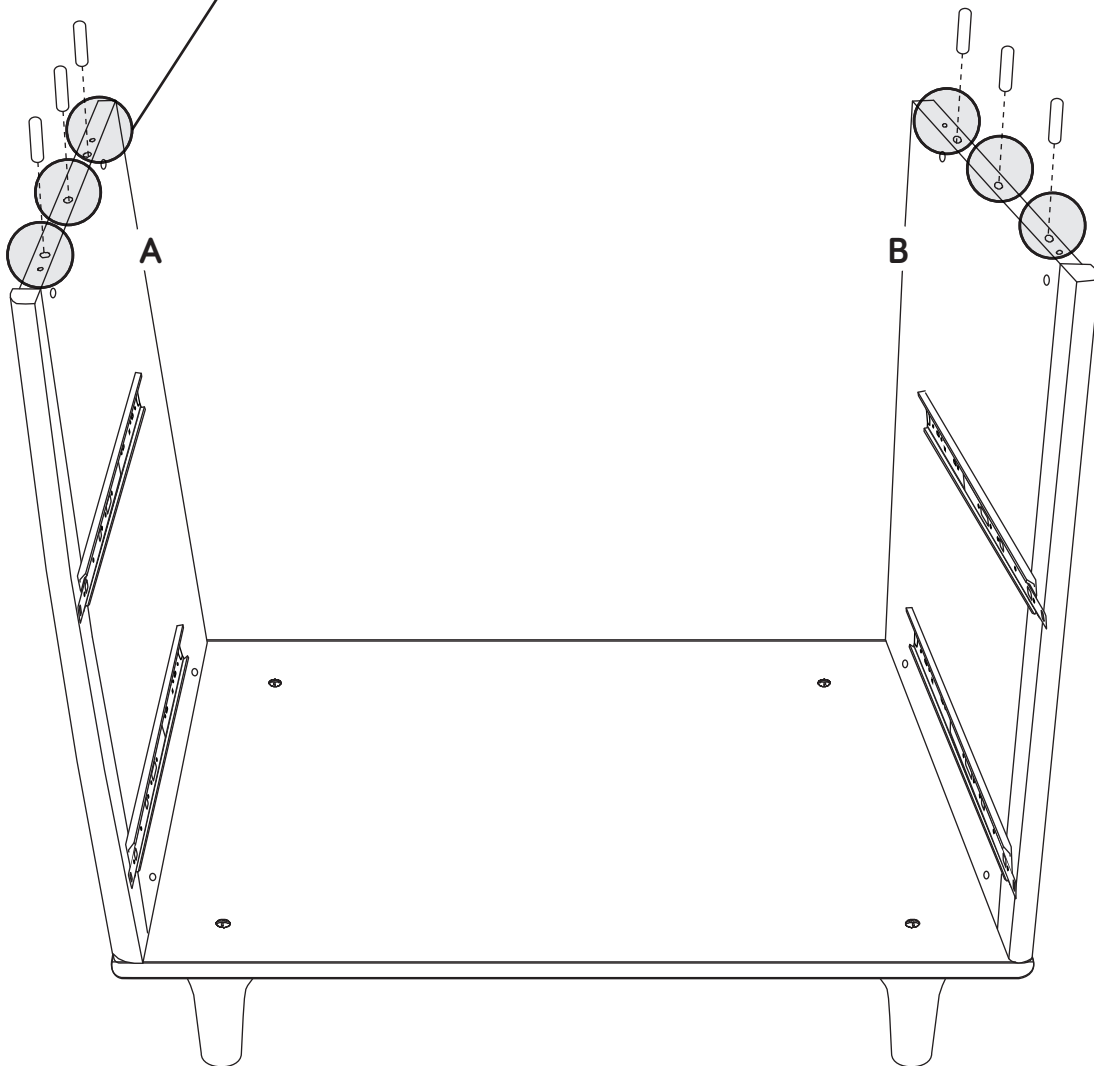

9

H6
x4

X4

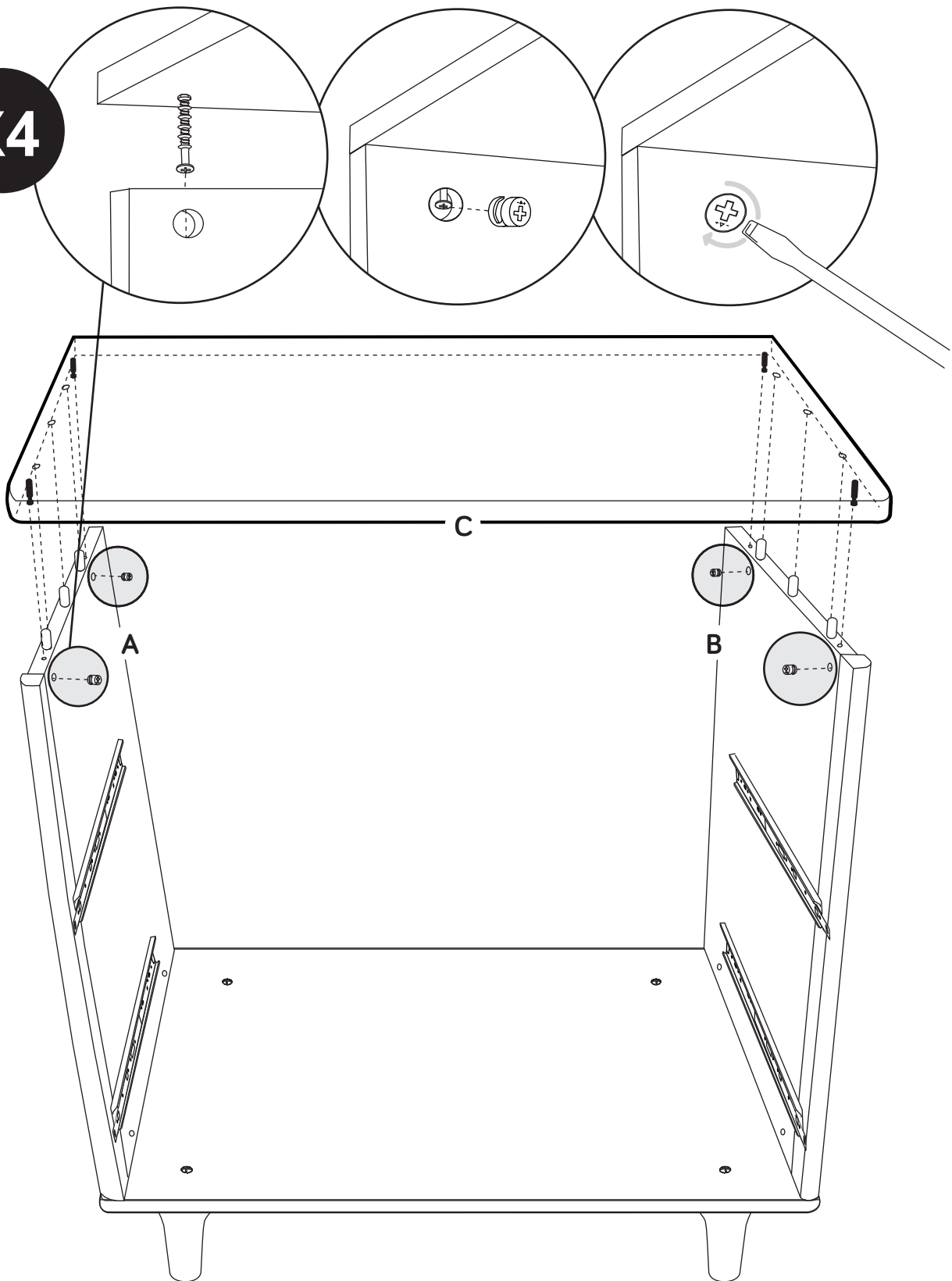

10

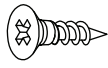

H4
x12



X12

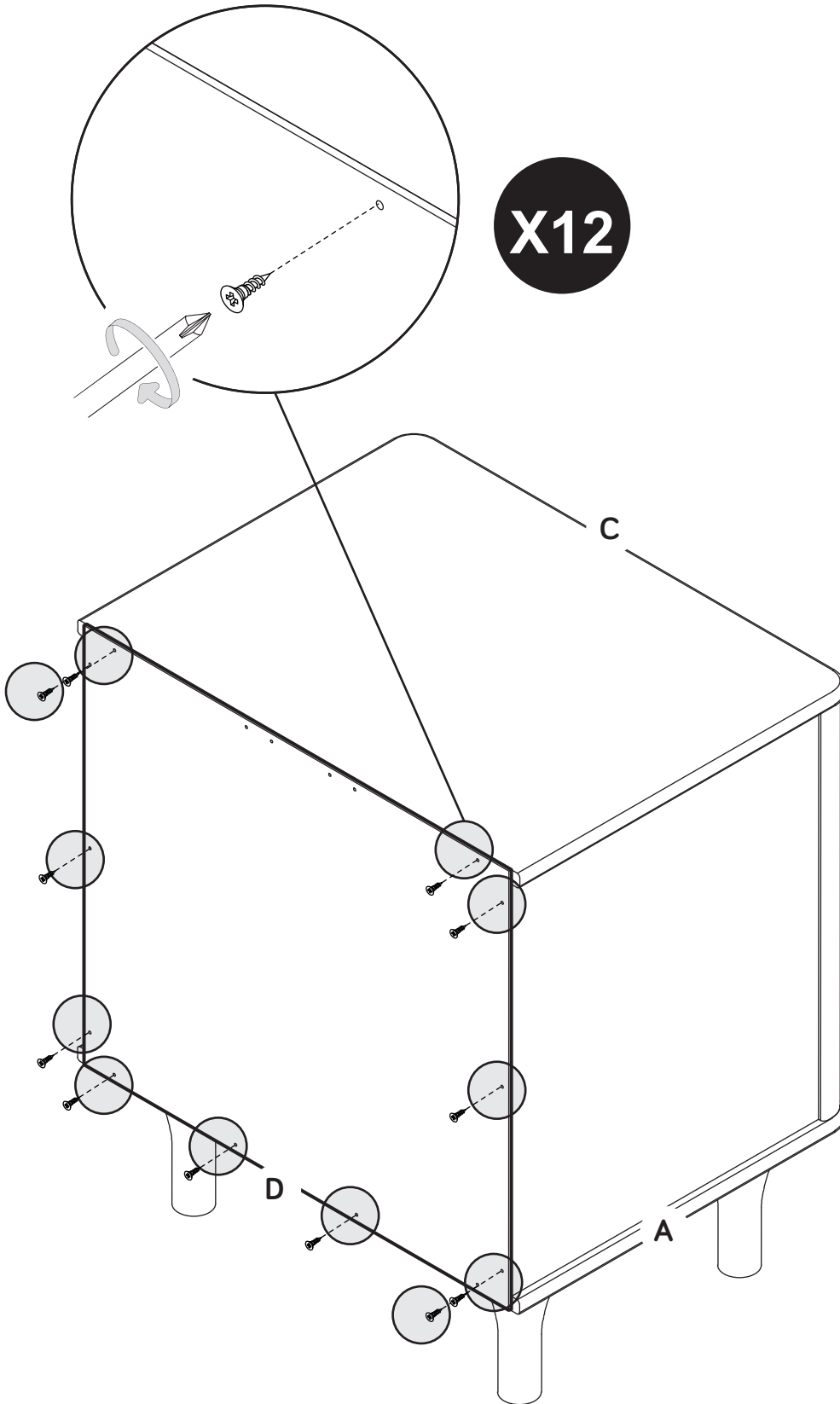

11



H3
x4

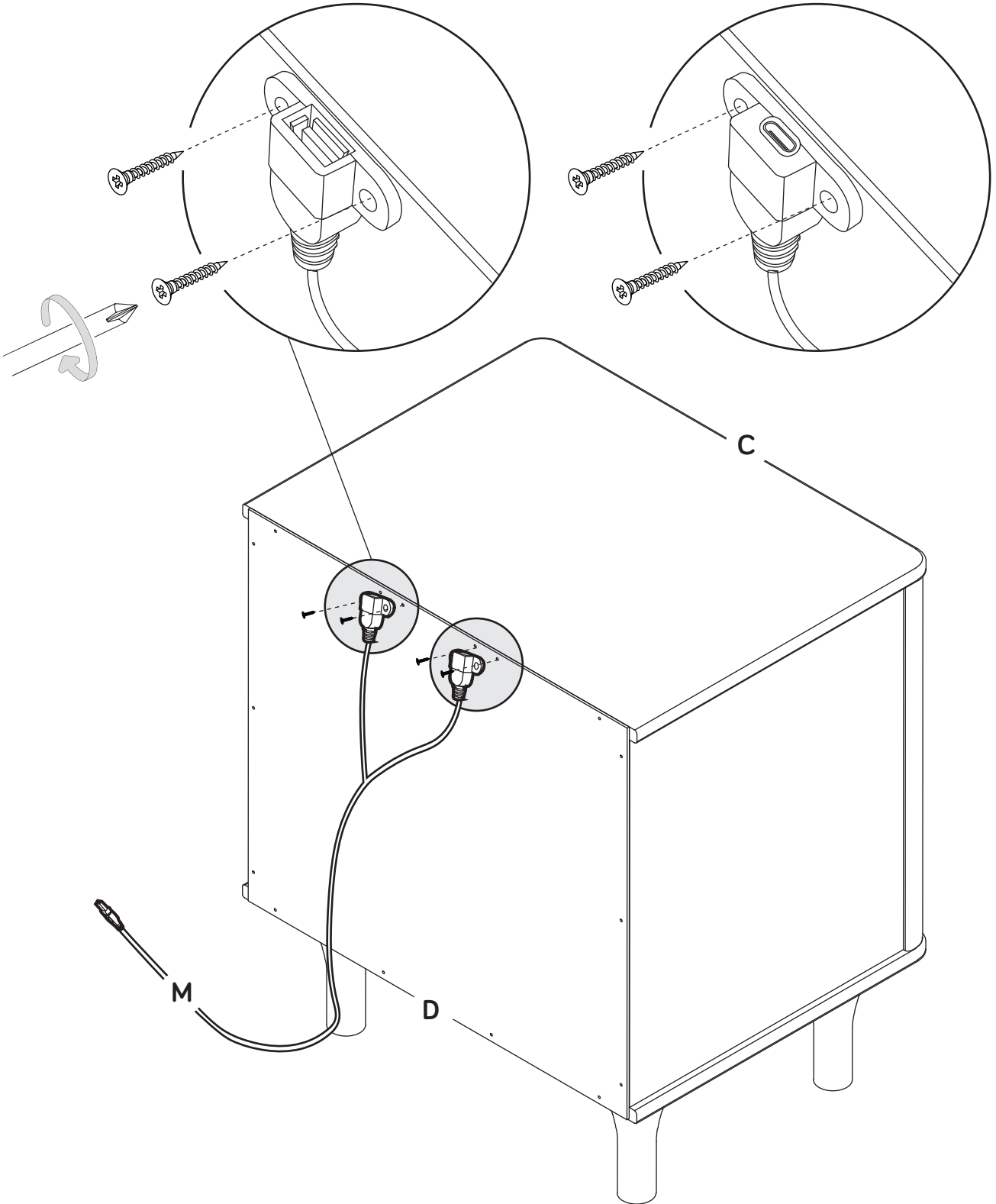

12a



H2
x4

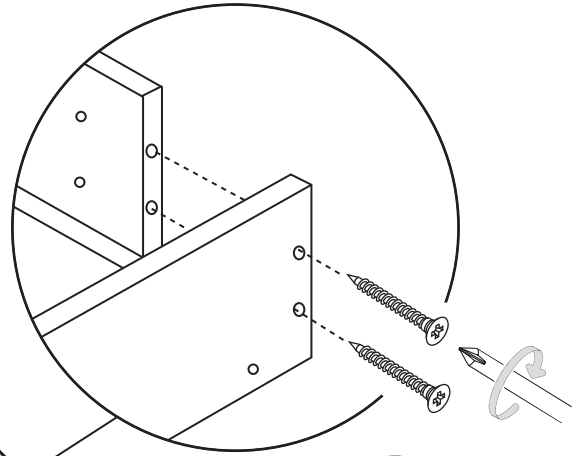
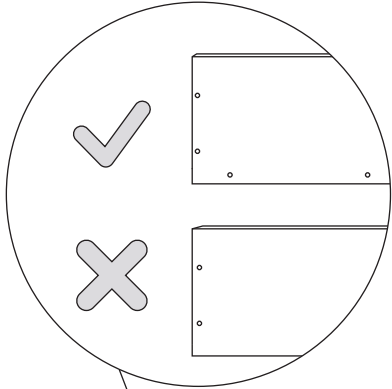

X2

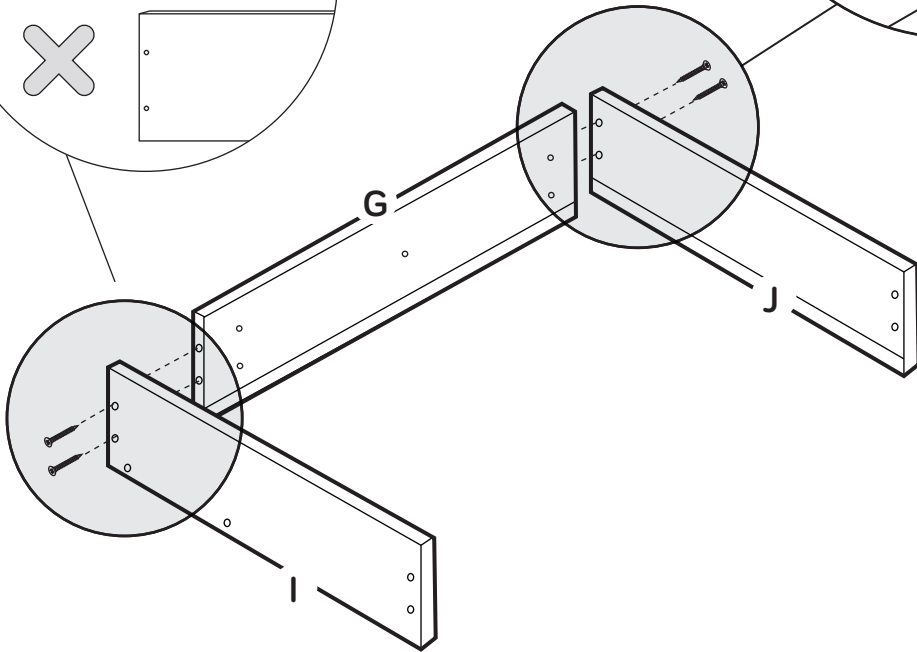

12b

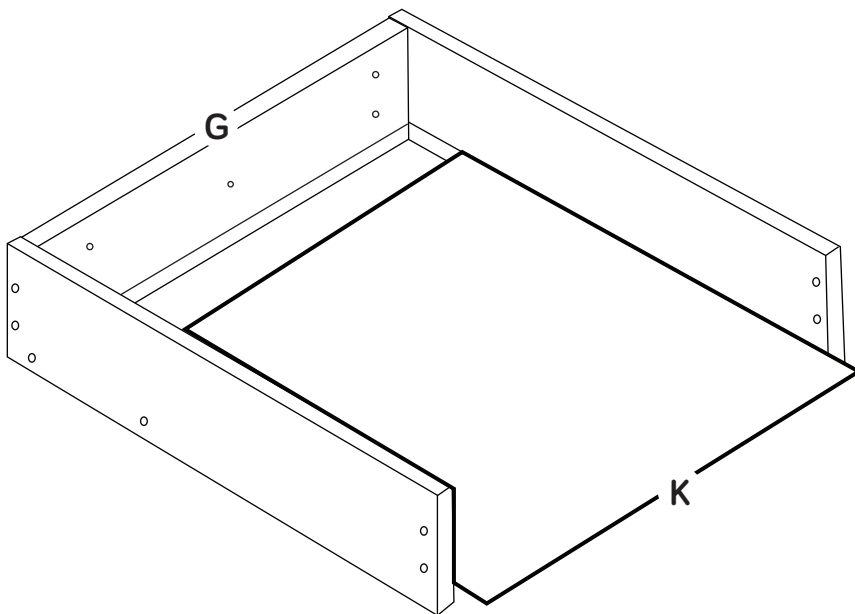

12c



H2
x4

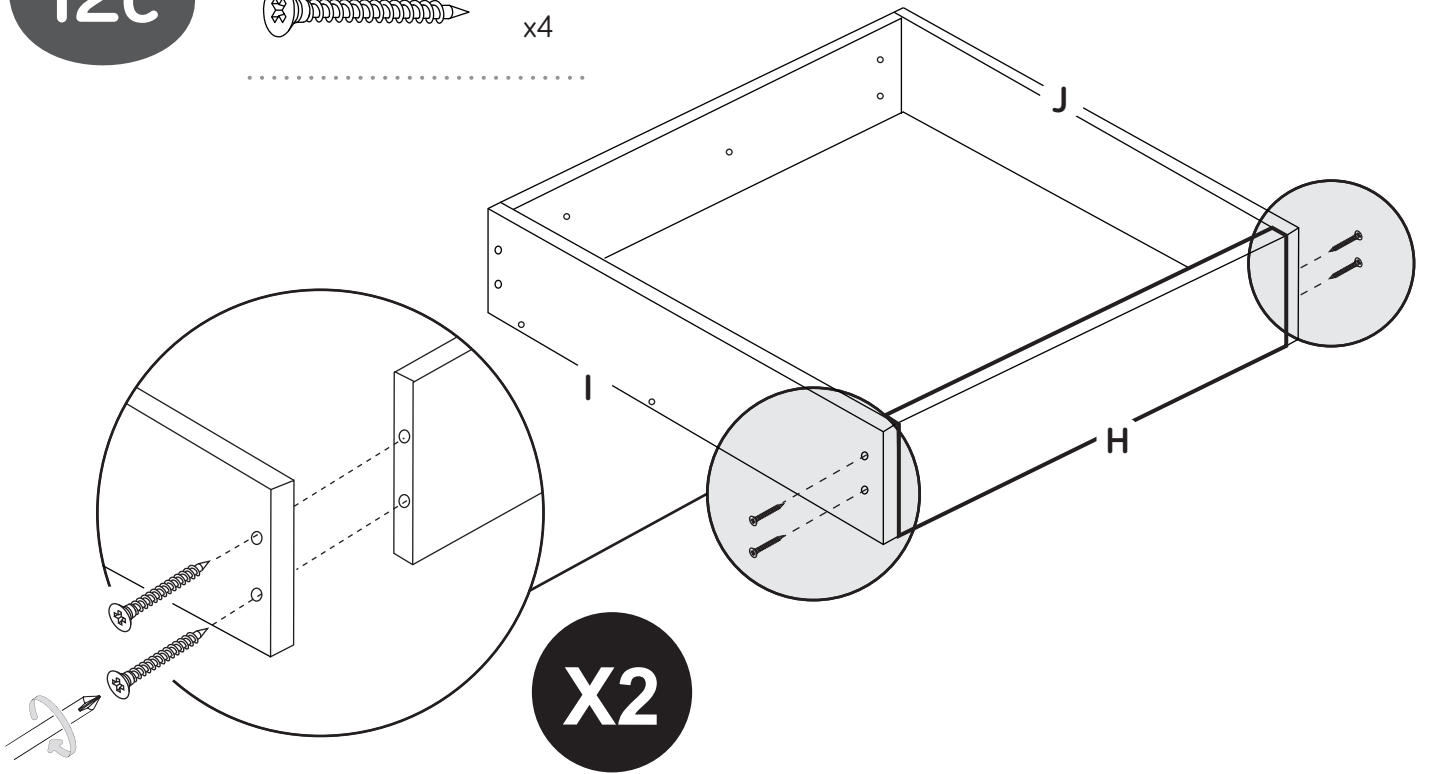

12d



H3
x4

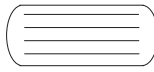

H9
x2

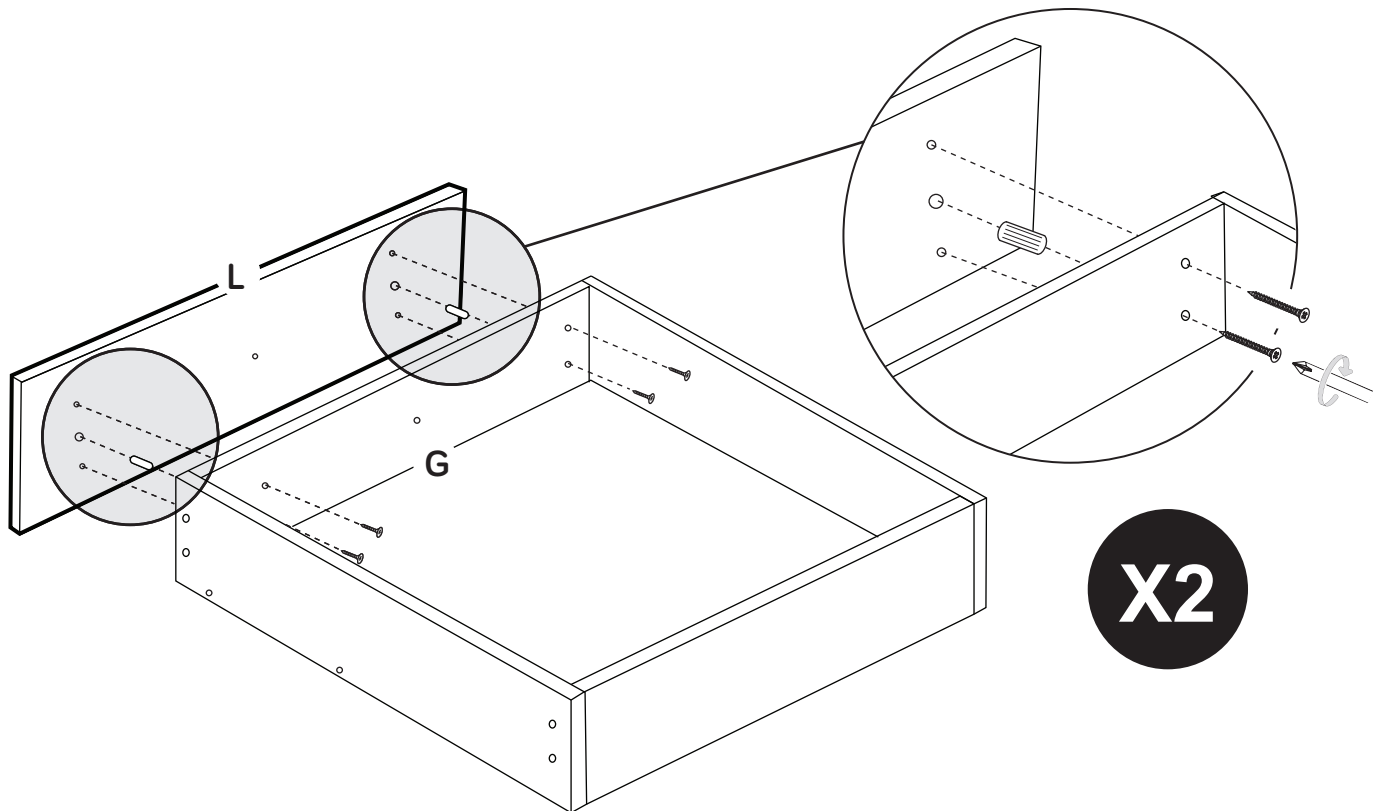

12e

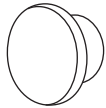

H10
x1



H11
x1

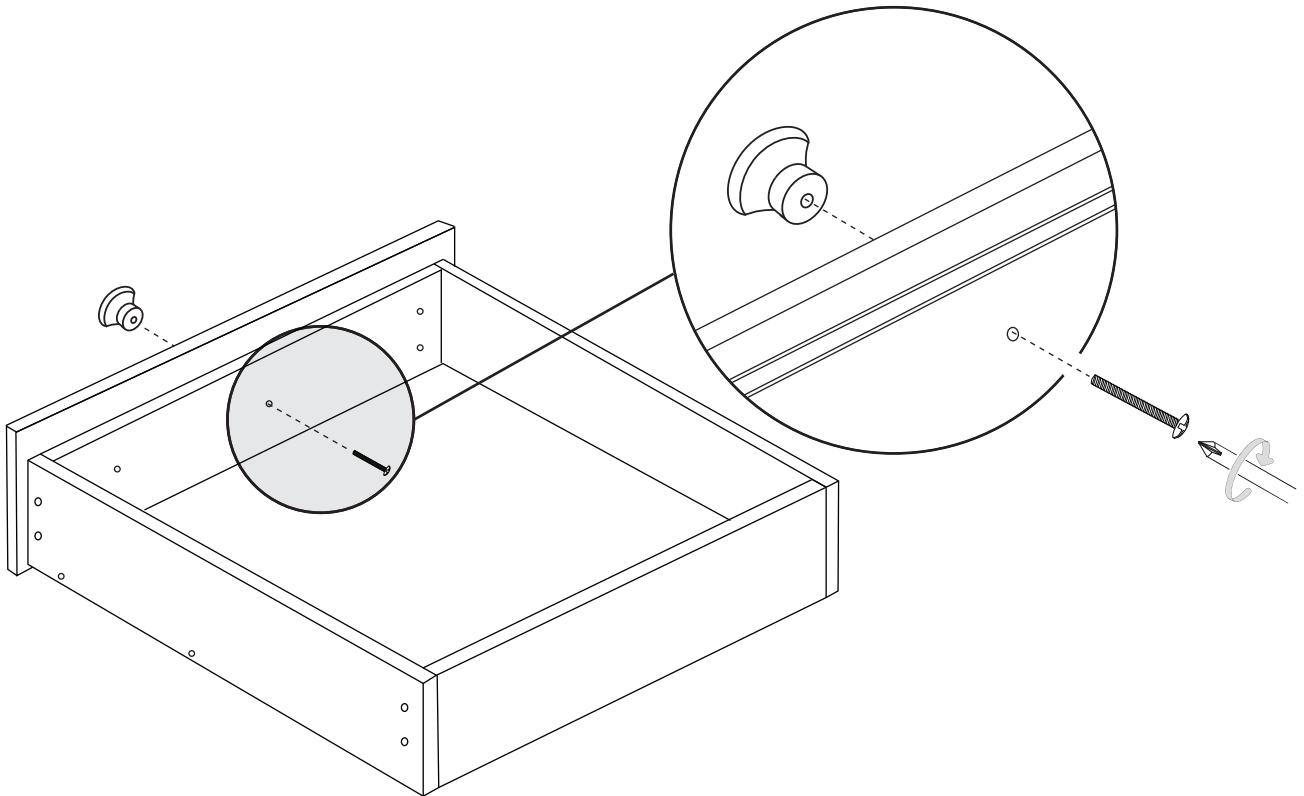

12f

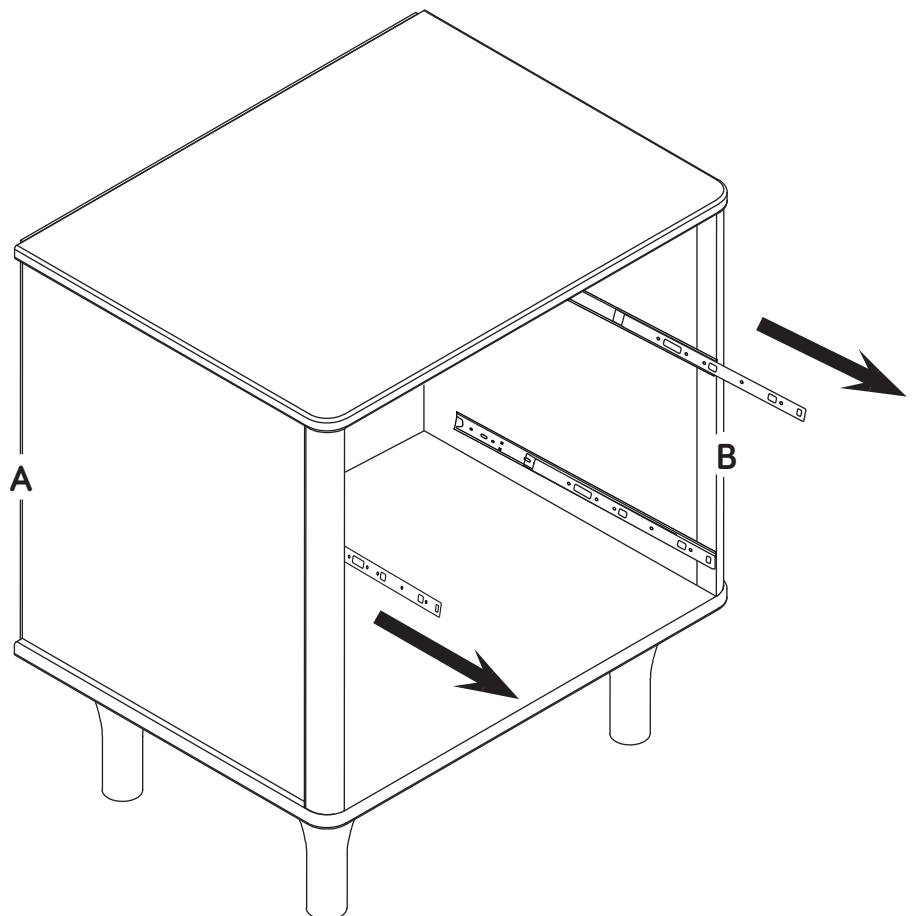

12g

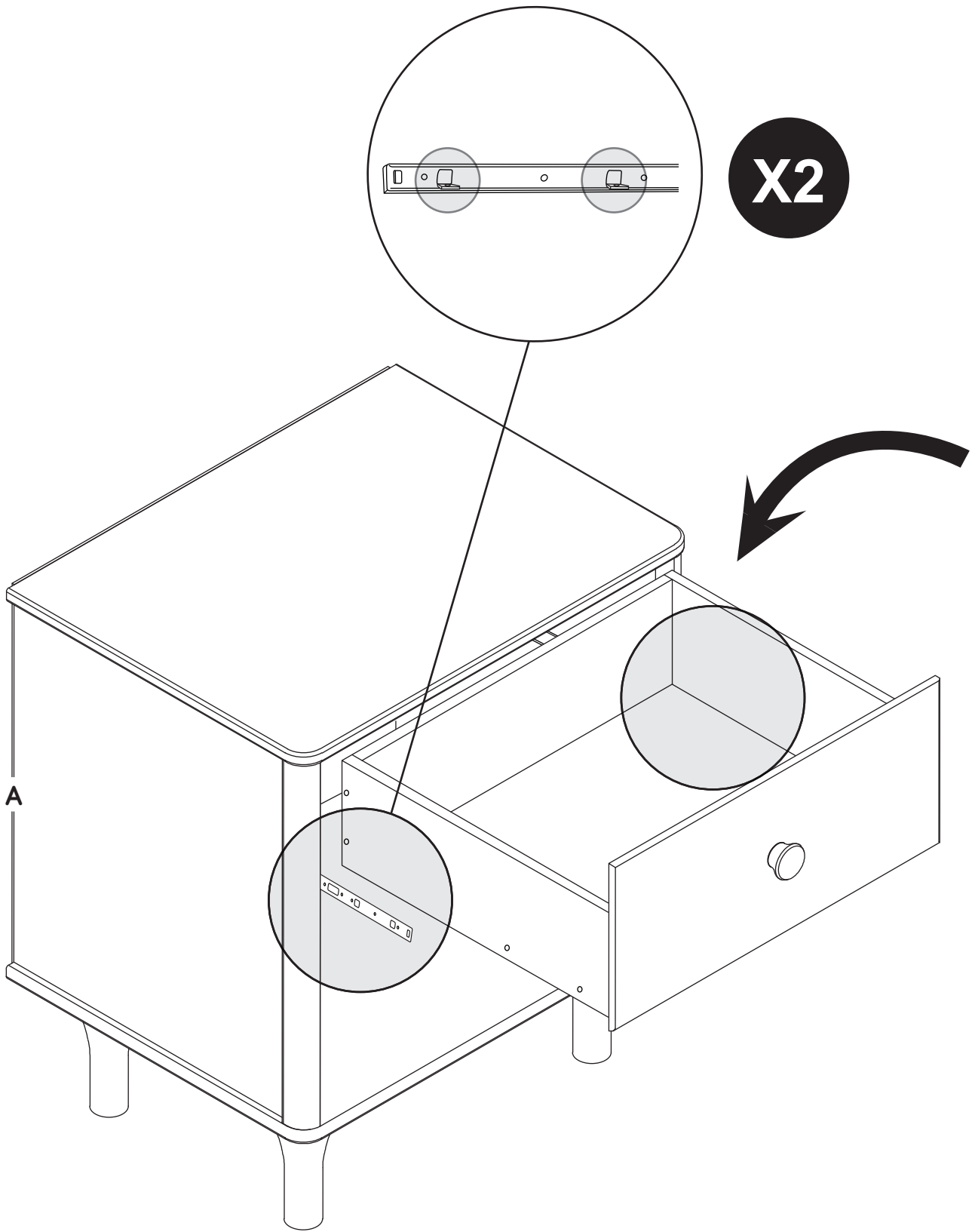

12h

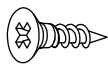

H4
x4

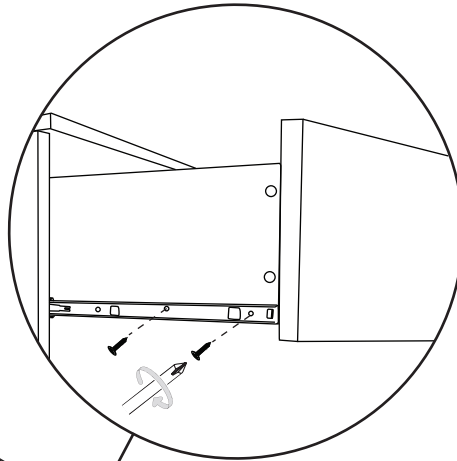

X2

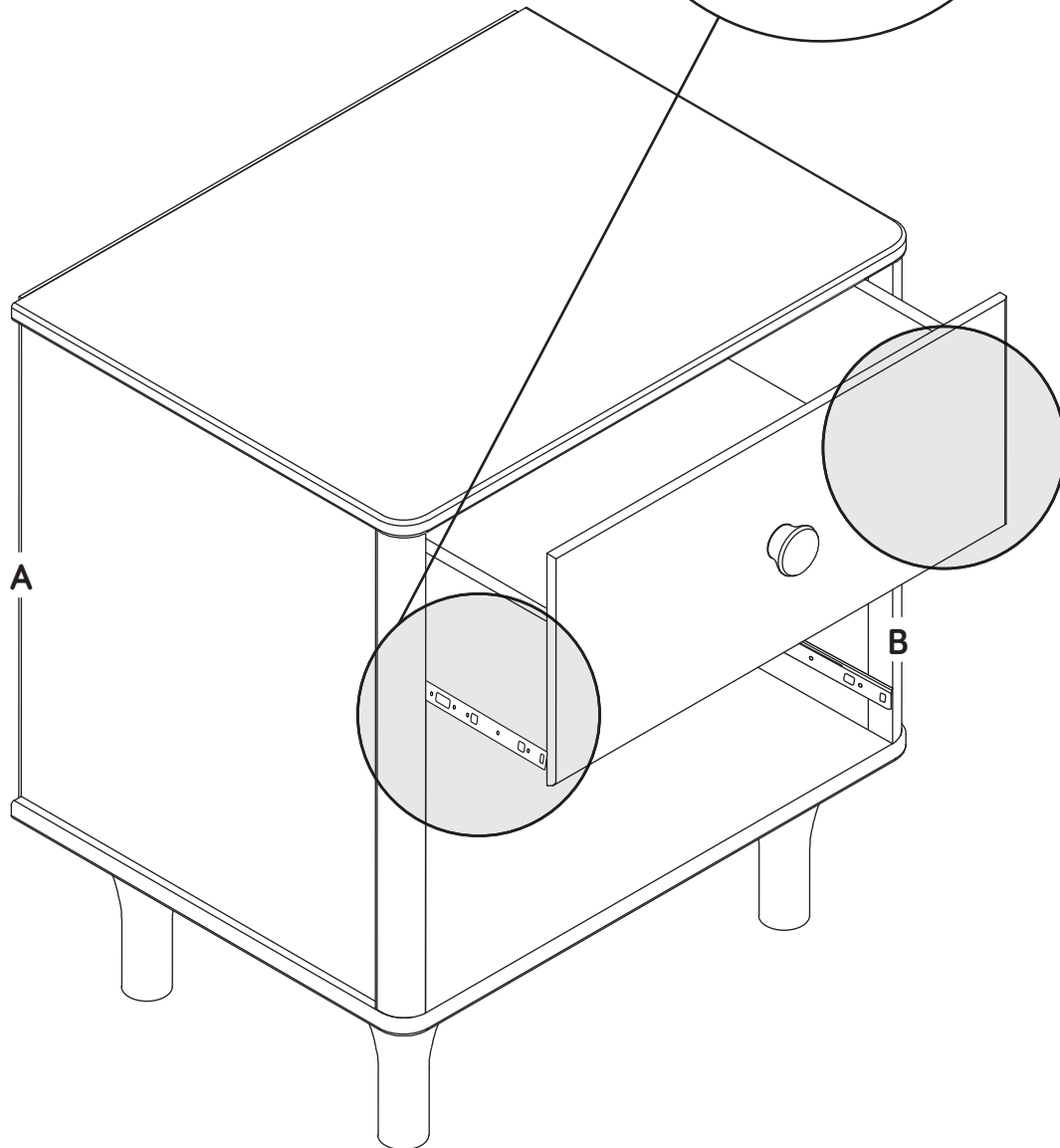

DO NOT OVERTIGHTEN THE SCREWS.
NO APRIETE LOS TORNILLOS EN EXCESO.
NE SERREZ PAS TROP LES VIS.

13



H2
x8



H3
x4

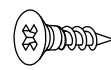

H4
x4

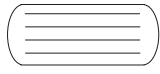

H9
x2

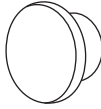

H10
x1

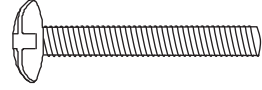

H11
x1

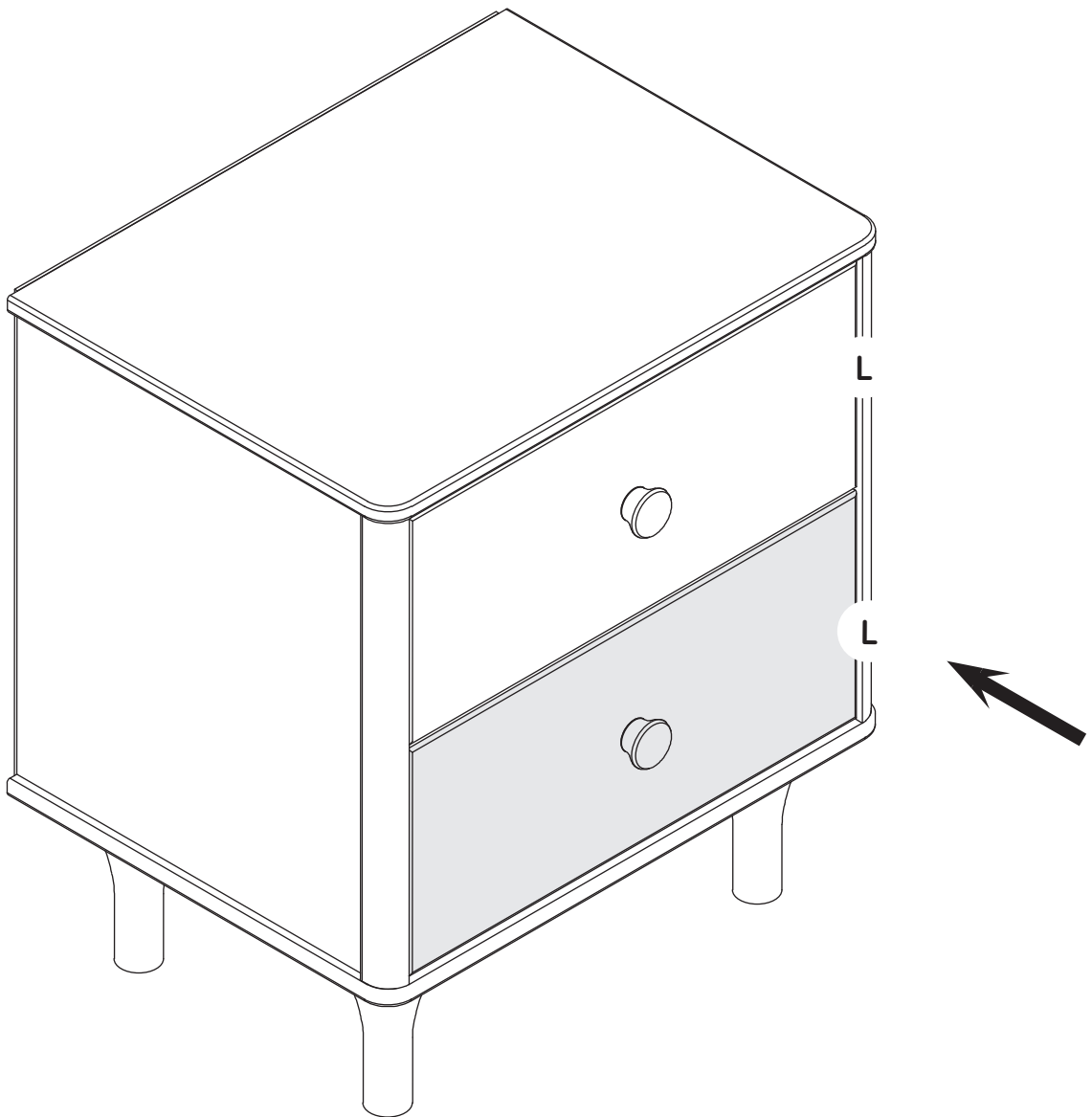

voila!

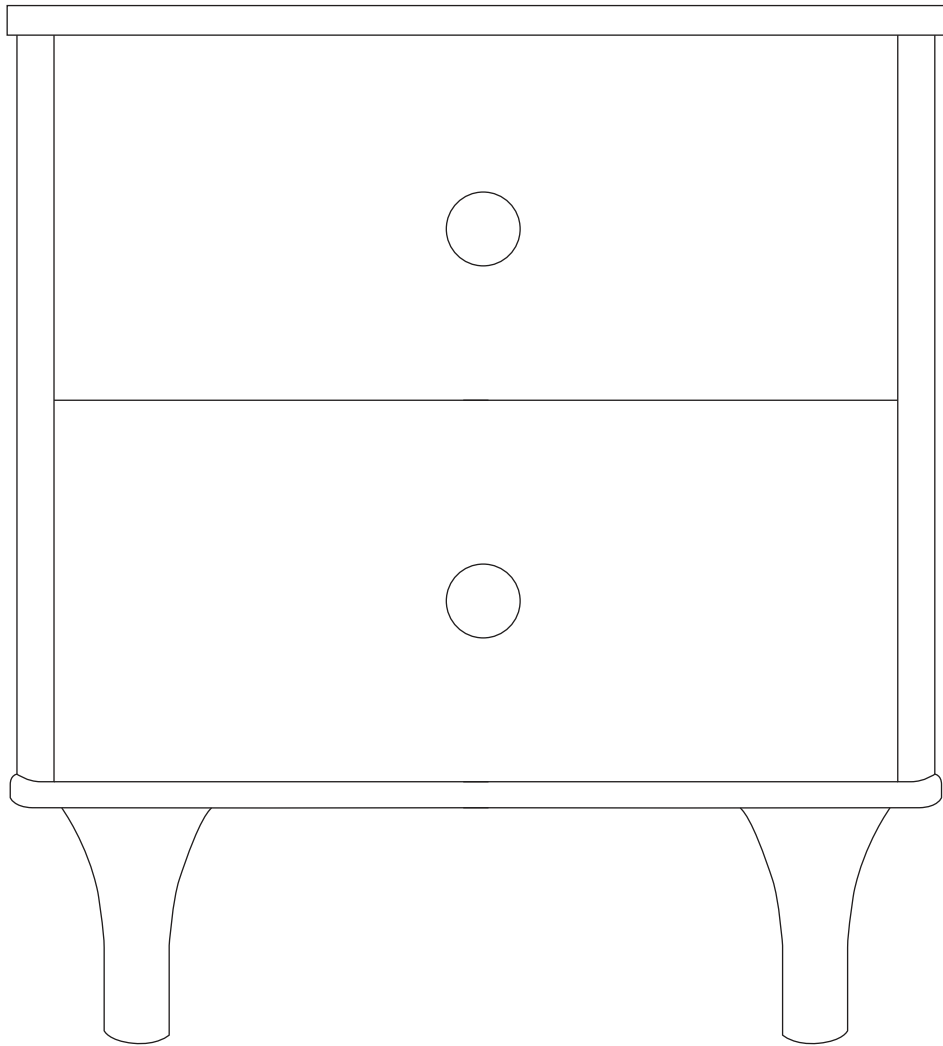

storage



Because materials respond to temperature and humidity, it is important to store furniture in controlled environments. Furniture should not be placed in direct sunlight or near air-conditioning outlets, radiators, heaters, or humidifiers. Any changes such as extreme heat or cold, dampness, or dryness, may cause noticeable shrinkage or swelling of wood. Direct sunlight may affect the coloring of materials over time.

care and cleaning



To clean wood or metal parts, use a lint-free, soft cloth with a non-toxic cleaner. Wipe dry immediately. To avoid scratches or other damages, do not use abrasive chemicals or materials. For fabrics, we recommend using a non-toxic foaming fabric cleaner or leather cleaner where appropriate. Touch up kits are available for purchase by contacting us at:

(323) 282-5163 or **INFO@MDBMAIL.COM**

registration



Registering your product is simple. You can do so at:

BABYLETTO.COM/REGISTRATIONS

part replacement



If you would like to order replacement or missing parts, please visit us at:

BABYLETTO.COM/PARTS

or you can contact us by mail at:

8700 REX RD. PICO RIVERA, CA 90660

one year limited warranty



Oops! Did we make a mistake? No worries, your Babyletto product is covered under warranty for one year after the date of purchase. For more details on our warranty policy, please visit:

BABYLETTO.COM/WARRANTY

almacenamiento



Dado que los materiales responden a la temperatura y la humedad, es importante guardar muebles en ambientes controlados. No deben ponerse los muebles a la luz solar directa ni cerca de salidas de aire acondicionado, radiadores, calefactores ni humidificadores. Cualquier cambio como los extremos de calor o frío, humedad o sequedad, pueden causar notoriamente encogimiento o hinchazón en la madera. La luz solar directa puede afectar la coloración de los materiales con el paso del tiempo.

cuidado y limpieza



Para limpiar piezas de madera o metal, use un paño suave sin pelusa con un limpiador no tóxico. Seque con un paño inmediatamente. Para evitar rayar o dañar la superficie, no use agentes químicos ni materiales abrasivos. En cuanto a las telas, recomendamos usar una espuma limpiadora no tóxica para telas o un limpiador para cuero según corresponda. Hay kits para retocar disponibles para la venta contactándonos en: **(323) 282-5163** o **INFO@MDBMAIL.COM**

registrarse



Es sencillo registrar su producto. Puede hacerlo en:

BABYLETTO.COM/REGISTRATIONS

recambio de piezas



Si quisiera pedir repuestos o piezas faltantes, visítenos en:

BABYLETTO.COM/PARTS

o puede contactarnos por correo en:

8700 REX RD. PICO RIVERA, CA 90660

garantía limitada de un año



¡Ups! ¿Cometimos un error? No se preocupe, este producto Babyletto está cubierto por una garantía de un año a partir de la fecha de compra. Para conocer más detalles sobre nuestra política de garantía, visite:

BABYLETTO.COM/WARRANTY

rangement



Compte tenu que les matériaux réagissent à la température et à l'humidité, il importe de ranger le mobilier dans des environnements contrôlés. Le mobilier ne doit pas être placé en plein soleil ni près des sorties d'air climatisé, des radiateurs, des appareils de chauffage ou des humidificateurs. Tout changement comme un froid ou une chaleur extrême, de l'humidité ou de la sécheresse pourrait causer la contraction ou le gonflement du bois. La lumière directe du soleil peut altérer la couleur des matériaux au fil du temps.

nettoyage et entretien



Pour nettoyer le bois ou les pièces métalliques, utilisez un chiffon doux sans peluche et un produit nettoyant non toxique. Essayez immédiatement. Pour éviter les égratignures ou autres dommages, veillez à ne pas utiliser des produits chimiques ou des matériaux abrasifs. Pour les tissus, il est recommandé d'utiliser un produit nettoyant pour tissus non toxique ou pour cuir le cas échéant. Il est possible de se procurer des nécessaires de retouches en nous contactant à :
(323) 282-5163 ou **INFO@MDBMAIL.COM**

enregistrement



L'enregistrement du produit est simple à réaliser. Il suffit d'aller sur la page :

BABYLETTO.COM/REGISTRATIONS

pièces de rechange



Pour commander des pièces de rechange ou manquantes, veuillez visiter :

BABYLETTO.COM/PARTS

ou communiquer avec nous par courriel à l'adresse :

8700 REX RD. PICO RIVERA, CA 90660

garantie limitée d'un an



Oops! Avons-nous fait un erreur? Ne vous inquiétez pas. Votre produit Babyletto est couvert par une garantie d'un an à compter de la date d'achat. Pour plus de détails sur la politique de garantie, veuillez visiter :

BABYLETTO.COM/WARRANTY

