



MODEL NO.

**B2251**

**GB54cs2.0**

**BASKETBALL SYSTEM**

## OWNER'S MANUAL

1. **Read this manual carefully before starting assembly.** Read each step completely before beginning each step.
2. **Some smaller parts may be shipped inside larger parts. Check inside all parts and cartons before assembling or ordering parts.**
3. **To make assembly of your basketball system easier, use the Hardware Identifier on page 4 to identify and sort all fasteners. Check all cartons for kits. All hardware may not be located in one kit.**
4. **Do not tighten hardware until instructed to do so.** If hardware is tightened too soon, mounting holes may not align and parts may not easily fit together. Leave locknuts slightly loose until you are instructed to tighten them.
5. An electric screwdriver is helpful in assembly. However, please **set at low torque and use caution** because you could overtighten the hardware and strip the screws.
6. **Save this instruction and your proof of purchase (receipt) in the event that the manufacturer has to be contacted for replacement parts.**

### Please Do Not Return This Product To The Store!

Contact Escalade® Sports customer service department at:

**Phone: 1-888-USA-GOAL Toll Free!**

**Fax: 1-866-873-3536 Toll Free!**

**E-mail: basketball@escaladesports.com**

**Mailing Address (correspondence only):**

**Escalade Sports**

**PO Box 889**

**Evansville, IN 47706**

#### ITEMS NEEDED (NOT INCLUDED)

9 - 80 lb. bags of concrete	1 - wheel barrow
1 - Post hole digger (optional)	1 - garden hose
1 - Concrete form (see note after step 2)	
1 - 15/16" Open end Wrench	1 - Phillips Screwdriver
1 - 15/16" Socket and Ratchet (optional)	1 - Level
1 - 9/16" Deep Well Socket & Ratchet	1 - Tape Measure
1 - 9/16" Open end Wrench	1 - Rubber Mallet
1 - 3/4" Socket & Ratchet	1 - Set of Padded Saw Horses
1 - 3/4" Open end Wrench	
1 - Cordless drill & 9/64" drill bit	1 - Safety glasses
1 - 5/16" socket driver (for cordless drill)	1 - Ladder

Please visit our World Wide Web site at: **www.escaladesports.com**

**ON-LINE TROUBLE SHOOTING**

**TECHNICAL ASSISTANCE**

**ON-LINE PARTS REQUESTS**

**FREQUENTLY ASKED QUESTIONS**

**ADDITIONAL ESCALADE® SPORTS PRODUCT INFORMATION**

**ESCALADE®**  
**S P O R T S**

2L-7539-00

Escalade® Sports products may be manufactured and/or licensed under the following patents:  
6419596, 6179733, 5919102, 5071120, 4798381, 4424968, D326128, 7244046

Additional patents may be pending. One or more of the listed patents and/or pending patents may cover specific product.

©2012 Escalade® Sports



# SAFETY INSTRUCTIONS



**FAILURE TO FOLLOW THESE WARNINGS MAY RESULT IN SERIOUS INJURY AND/OR PROPERTY DAMAGE.**

**Owner must ensure that all players know and follow these rules for safe operation of the system.**



## WARNING

**FAILURE TO FOLLOW THESE WARNINGS MAY RESULT IN SERIOUS INJURY AND/OR PROPERTY DAMAGE.**

Owner must ensure that all players know and follow these rules for safe operation of the system.

- Do not dunk on this unit
- Do not hang from any part of the unit, including the backboard, rim, support braces, or net.
- Do not slide, climb, or play on pole.
- Keep organic material away from pole base. Grass, litter, etc. could cause corrosion and/or deterioration.
- Check pole system for signs of corrosion (rust, pitting, chipping). Remove rust and/or loose paint completely and repaint with exterior enamel paint. If rust has penetrated through the steel anywhere, replace pole immediately.
- Check system before each use for proper ballast, loose hardware, excessive wear, and signs of corrosion and repair before using.
- During play, use extreme caution to keep players face away from the backboard, rim, and net. Serious injury could occur if teeth/face come in contact with backboard, rim, or net.
- Wear a mouth guard when playing to avoid dental injuries.
- When adjusting height, keep hands and fingers away from moving parts.
- During play, do not wear jewelry (rings, watches, necklaces, etc.). Objects may entangle in net.
- Do not allow children to adjust system.
- Check system before each use for instability.
- Never play on damaged equipment.

4L-7609-00



## SAFETY INSTRUCTIONS



**FAILURE TO FOLLOW THESE SAFETY INSTRUCTIONS MAY RESULT IN SERIOUS INJURY, PROPERTY DAMAGE AND WILL VOID WARRANTY.**

Owner must ensure that all players know and follow these rules for safe operation of the system.

To ensure safety, do not attempt to assemble this system without following the instructions carefully. Proper and complete assembly, use and supervision is essential for proper operation and to reduce the risk of accident or injury. A high probability of serious injury exists if this system is not installed, maintained, and operated properly.

- If using a ladder during assembly, use extreme caution.
- 4 people are recommended for this operation.
- Seat the pole sections properly (if applicable). Failure to do so could allow the pole sections to separate during play.
- Before digging contact utility company to locate underground power cables, gas and water lines. Ensure there are no overhead power lines within 20 ft. (7m) radius of pole location.
- Climate, corrosion or misuse could result in system failure.
- If technical assistance is required, contact the manufacturer.
- Minimum operational height is 6'6" (1.98m) to the bottom of backboard.

*Most injuries are caused by misuse and/or not following instructions.  
Use caution when using this system.*

## WARNING!



**Failure to observe this warning may cause property damage and/or serious injury.**

(Affixed to backboard)

This product is NOT designed to support a player hanging from any component of this basketball system. Rim height adjustments should be made under parental supervision. Wear a mouth guard when playing to avoid dental injuries. During play, do not wear jewelry (rings, watches, necklaces, etc). Objects may entangle in net.

 <h1 style="margin: 0;">WARNING</h1>
<p><b>DO NOT DUNK ON THIS UNIT . DO NOT HANG FROM ANY PART OF THIS UNIT , INCLUDING THE BACKBOARD, RIM, SUPPORT BRACES OR NET.</b></p> <p style="text-align: right; font-size: small;">4L-8152-00</p>

(Affixed to Top Post)

<p><b>Bottom of upper pole must cover the above orange portion of this sticker (6" mark).</b></p>
 <h1 style="margin: 0;">WARNING</h1>
<p><b>FAILURE TO FULLY ENGAGE THE BOTTOM OF THE UPPER POLE TO THE 6" MARK ON THIS BOTTOM POLE STICKER, COULD CAUSE YOUR UNIT TO COLLAPSE AND MAY RESULT IN SERIOUS INJURY OR PROPERTY DAMAGE.</b></p>
<h2 style="margin: 0;">BACKSIDE</h2> <p style="text-align: right; font-size: small;">4L-8151-00</p>

(Affixed to Bottom Post)

# BASKETBALL SYSTEM'S HARDWARE IDENTIFIER

Note: Check all cartons for hardware. All hardware is not packed in one kit.

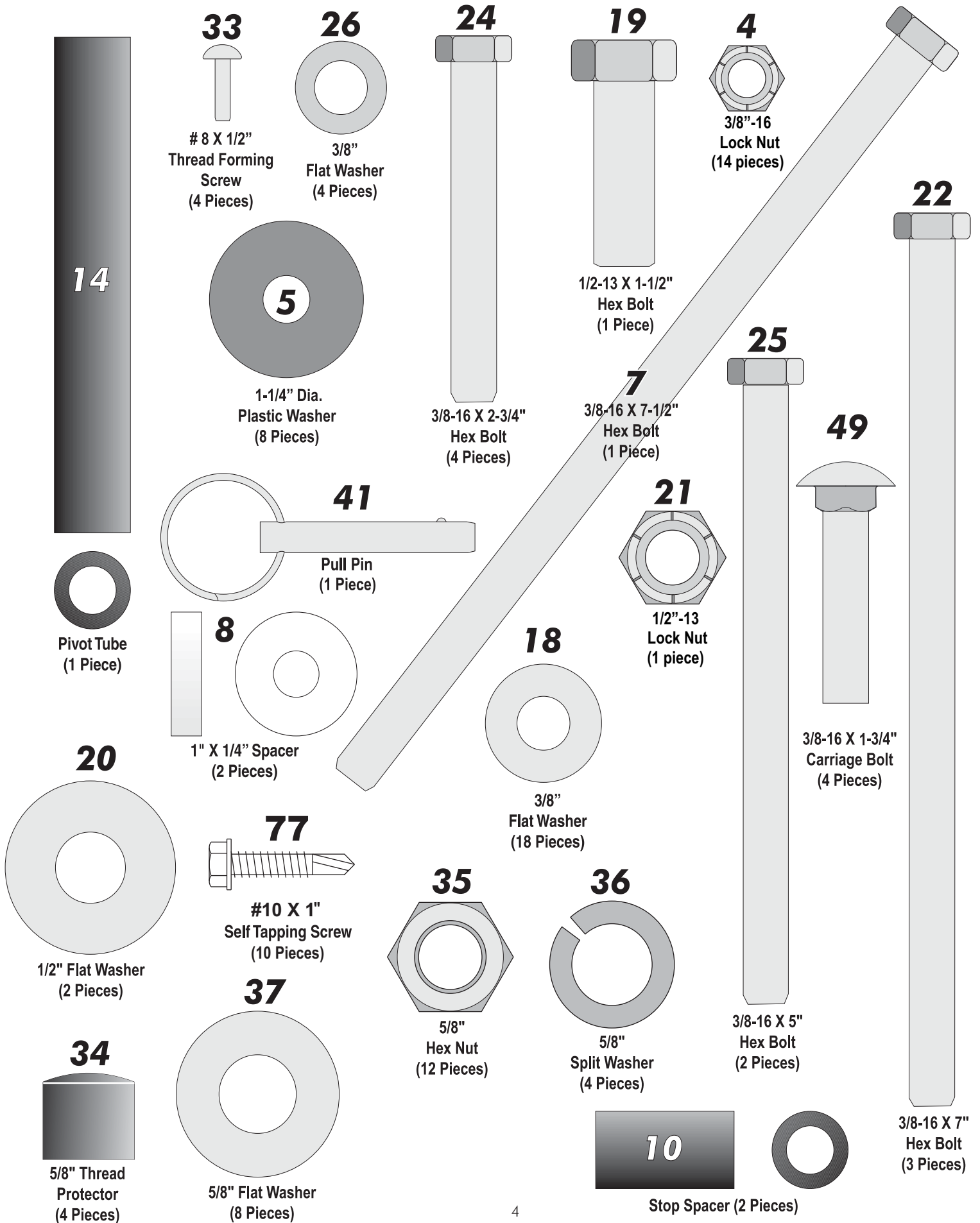

# INSTALLATION TIMELINE

1. Prior to anchor system and goal assembly, call utility services for location of underground utility lines before you dig.
2. Vertical main post assembly is a two part process.

## PART 1

**Day 1.** Complete Anchor System Installation Instructions. (Below)

**Day 2-4.** Allow concrete to cure.

## PART 2

**Day 5.** Complete Goliath® assembly instructions. (Requires four adults)

## ANCHOR SYSTEM INSTALLATION INSTRUCTIONS (Day 1)



**Before digging hole for anchor system, check for buried power, gas, water, and telecommunication lines! Failure to do so could result in serious or fatal injury! Contact your local utility company if unsure.**

### Items needed for Anchor Installation (not included)

- |   |                  |
|---|------------------|
| 9 - 80 lb. bags of concrete               | 1 - wheel barrow |
| 1 - post hole digger (optional)           | 1 - garden hose  |
| 1 - 15/16" open end wrench                | 1 - level        |
| 1 - 15/16" socket and ratchet (optional)  | 1 - tape measure |
| 1 - concrete form (see note after step 2) |                  |

**Note: For best results with less vibration, anchor system should be independent of court. If pouring concrete for both at same time, add an expansion joint in between.**

**Note: When digging hole, if you hit rock and cannot dig through contact a contractor.**

1. Determine the location of the anchor system. The proper location is as close to the court without making contact, as shown in Figure 1. This, however, is a general rule. If you need to locate the anchor system in a location other than this, use the following dimensions as a guide.

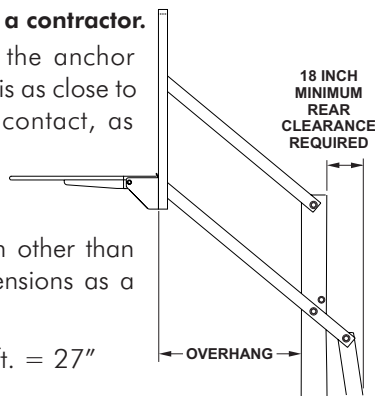

Overhang when adjusted to 10 ft. = 27"

**Note: Minimum of 18" rear clearance is required behind pole.**

2. Assemble anchor system as follows: Thread nut (#35) to bottom of threads on anchor bolt (#39) insert threads of anchor bolt (#39) through hole on anchor plate (#38) and secure with nut (#35). Repeat this step for the remaining anchor bolts. See Figure 2. Note: Each leg of anchor bolts should face the anchor bolt to the right. See Detail A.

**Detail A  
Bottom View**

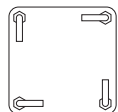

**Figure 2**

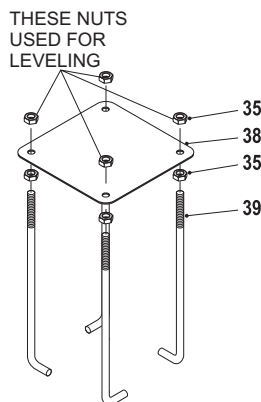

**Figure 1**

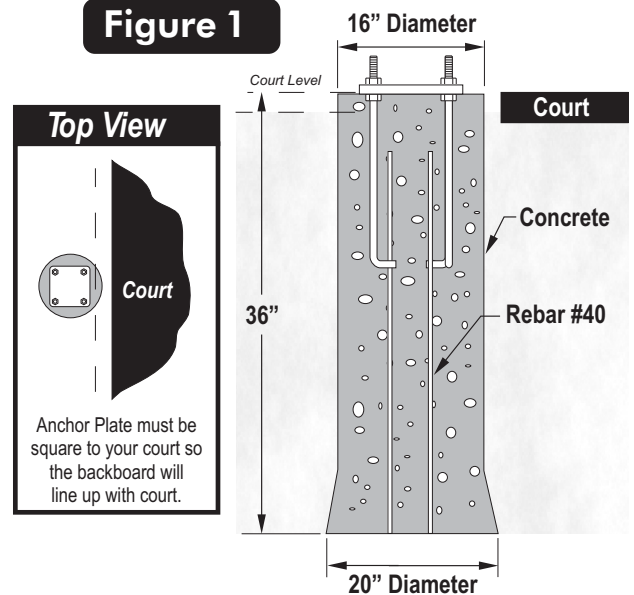

**Note: It is recommended that you use some sort of concrete form for the top 4" of the concrete. Cardboard forms can be purchased at some hardware and home stores or a wooden form can be constructed out of 2 x 4's.**

**Note: Failure to dig and fill hole as instructed will result in increased system vibration.**

3. Mix and pour concrete into hole. Follow instructions on concrete bag. Stop about 18" below court level.
4. Insert four reinforcement bars (#40) into concrete 8" apart creating a square in center on hole.
5. Finish pouring concrete up to court level.
6. Push anchor system into concrete and agitate to work out voids in concrete. Immediately use a level to level and square anchor plate to playing surface. Clean off any concrete that may be on exposed threads.

**Note: The bottom four nuts will be forever embedded in concrete. The top four nuts remain on bolts and are used for leveling. (See Step 15 on page 9).**

Let concrete stand for a MINIMUM of 72 hours.

# ASSEMBLY INSTRUCTIONS (Day 5)

## TOOLS REQUIRED FOR THE FOLLOWING STEPS

- |  |                              |
|--|------------------------------|
| 1 - 15/16" Open end Wrench                   | 1 - Phillips Screwdriver     |
| 1 - 15/16" Socket and Ratchet (optional)     | 1 - Level                    |
| 1 - 9/16" Deep Well Socket & Ratchet         | 1 - Tape Measure             |
| 1 - 9/16" Open end Wrench                    | 1 - Rubber Mallet            |
| 1 - 3/4" Socket & Ratchet                    | 1 - Set of Padded Saw Horses |
| 1 - 3/4" Open end Wrench                     |                              |
| 1 - Cordless drill & 9/64" drill bit         | 1 - Safety glasses           |
| 1 - 5/16" socket driver (for cordless drill) | 1 - Ladder                   |

- Before putting any of the poles tubes together, make sure that the orange area of the Warning Sticker on Pole (#2) is 6 inches from the top end. **Be sure that the "Back Side" stickers are at the back of the pole.** See Figure 3.

**WARNING: This pole assembly is heavy. Step 2 may require two adults. Make sure you can control the pole when slamming it together. If you are unsure if you can safely control the pole ask another adult to help you. This helper can stand on the opposite side of the pole. Attention should be paid to one's feet and toes during entire slamming process.**

- Align the upper pole (#3) with the bottom pole (#2) as shown in Figure 3 and slide them together. While maintaining control of the pole assembly stand poles up **STRAIGHT** on a piece of cardboard from your box, **lift poles up by bottom pole** below the 6" mark shown on sticker and slam down the bottom pole as many times as needed on the cardboard **until the bottom of the upper pole reaches the 6" mark** (on Sticker) on the bottom pole. **See Figure 3.** Should any concerns exist about damaging your driveway, use a 12" X 12" piece of Plywood or mdf board.

**IMPORTANT! DO NOT hit poles with hammer or sledge hammer to attach poles together.**

**NOTE:** When slamming poles together make sure to keep the poles **straight**. Slamming the poles down crooked will damage the bottom of the pole and base plate. Top Pole must cover upper orange area of sticker. If Pole goes slightly past the 6" mark, it is OK.

If you want to see a video on how to put the poles together go to:

<http://www.escaladesports.com/customer-service/instruction-videos/basketball>

Or Scan with your smart phone:



**NOTE:** Self Drilling screws (#77) are used. Holes are only on outside Pole. User must insert screws through BOTH POLES.

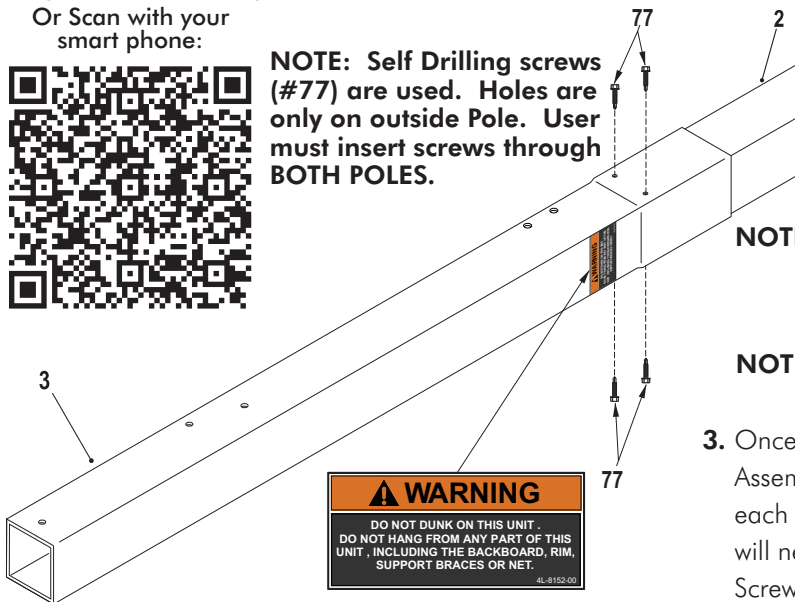

**Figure 4**

**WARNING**  
DO NOT DUNK ON THIS UNIT.  
DO NOT HANG FROM ANY PART OF THIS UNIT, INCLUDING THE BACKBOARD, RIM, SUPPORT BRACES OR NET.

Be sure that the "Back Side" stickers are at the back of the poles.

**Figure 3**

**NOTE:** Top Pole must cover upper orange area of sticker. If Pole goes slightly past the 6" mark, it is OK.

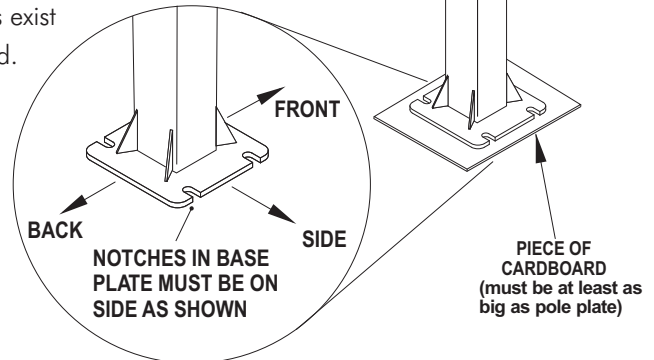
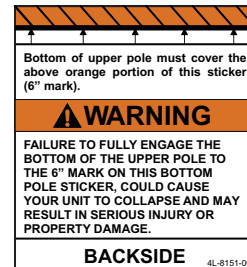

**CAUTION**  
SCREWS (#77) MUST BE INSTALLED TO POLE AS DESCRIBED IN STEP 3. FAILURE TO INSTALL SCREWS COULD RESULT IN SERIOUS INJURY OR PROPERTY DAMAGE.

**NOTE:** Cordless drill required for screw installation. Do not over tighten screws causing screws to strip. Once Screw heads touch pole, STOP! Overtightening will cause Pole to Warp and damage system.

**NOTE:** To install screws, it will be easier if you use a cordless drill with 5/16" socket (instead of Phillips head).

- Once the Top pole is to the 6" Mark on the Warning Sticker, lay Pole Assembly on its side on two padded saw horses. Insert a (#77) Screw into each 3/16" hole in top Pole, two on each side of the Post Assembly. You will need someone to hold the Pole assembly while inserting screws. Screw must go through both Top and Bottom (Inner) Poles. Make sure to not strip screws once they are all the way through. See Figure 4.

**NOTE:** Screws #77, used in step 3, are Self Drilling screws and can be installed without drilling pilot holes. However, it will be easier to install screws if you drill 9/64" pilot holes in bottom pole. **WEAR SAFETY GLASSES** if drilling holes.

- Attach Post Ears (#30) to holes near the bottom of Top Post (#3) using two Hex Bolts (#25) four Washers (#18) and two Lock Nuts (#4). Do not tighten nuts (#4) completely until instructed to do so. See **Figure 5**.
- If not already pre-assembled, slide Plastic Actuator Sleeve (#15) over Steel Actuator (#16) and place Actuator Cap (#13) on top. Align holes in all 3 parts and slide Pivot Tube (#14) through holes in Actuator Cap (#13), Plastic Actuator Sleeve (#15) and Steel Actuator (#16) until equal amounts stick out through both sides of actuator. See **Figure 6**.

**Note: If necessary, use a rubber mallet to tap in Pivot Tube (#14)**

- While still on the two padded saw horses, Slide tab on Actuator (#16) between Post Ears (#30) and secure using one bolt (#19), two washers (#20) and one lock nut (#21). Tighten Lock Nut (#21) snug but **do not over tighten**. See **Figure 6**. At this time **also tighten nuts (#4) from Step 4**.
- Place Pole Cap (#1) onto top of Top Pole (#3). Note: Pole Cap may be pre-installed by the factory.
- Secure two stop spacers (#10) to pole, as shown in Figure 6, using one hex bolt (#22) and one lock nut (#4). Tighten Lock Nut (#4) but **do not over tighten**.

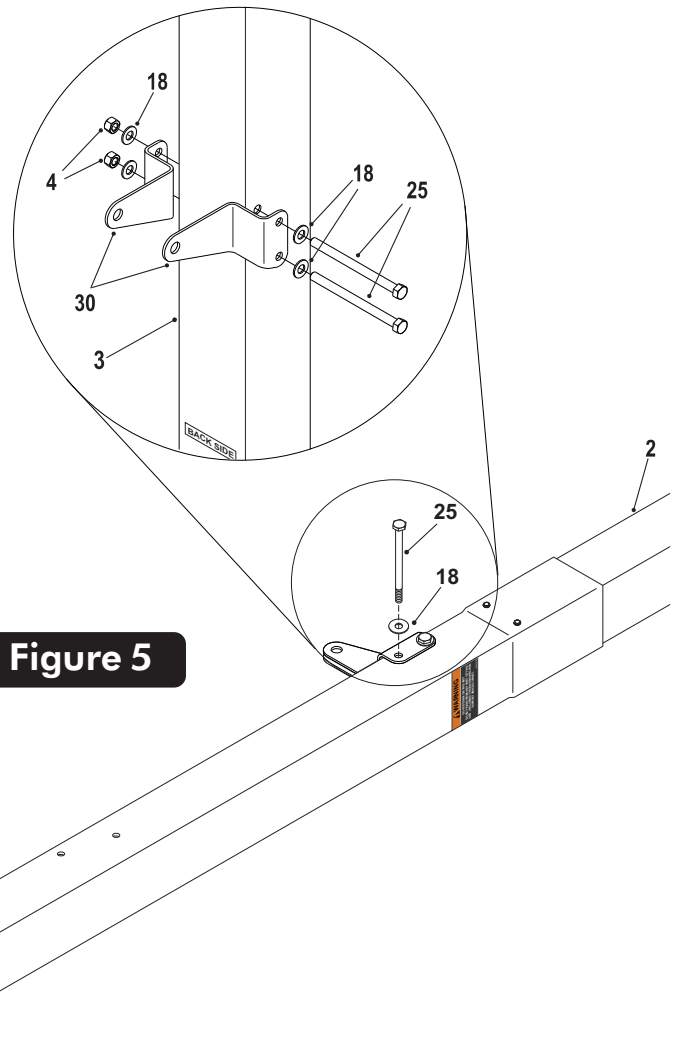

**Figure 5**

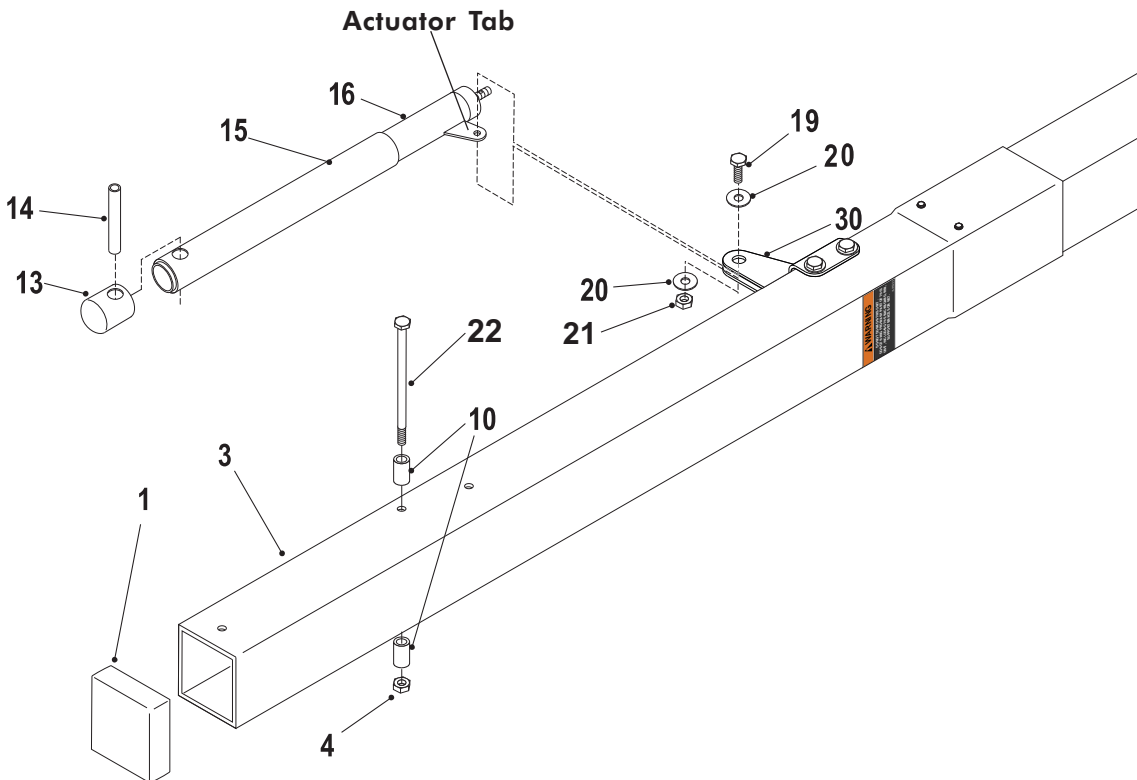

**Figure 6**

**IMPORTANT! Nylon washers (#5) adequately space painted parts at all pivot points. Neglecting the use of these washers will result in rusted parts.**

**NOTE: All board arms are made of rectangular tubing. Tightening hardware too tight may damage tubing and make adjustment of system difficult.**

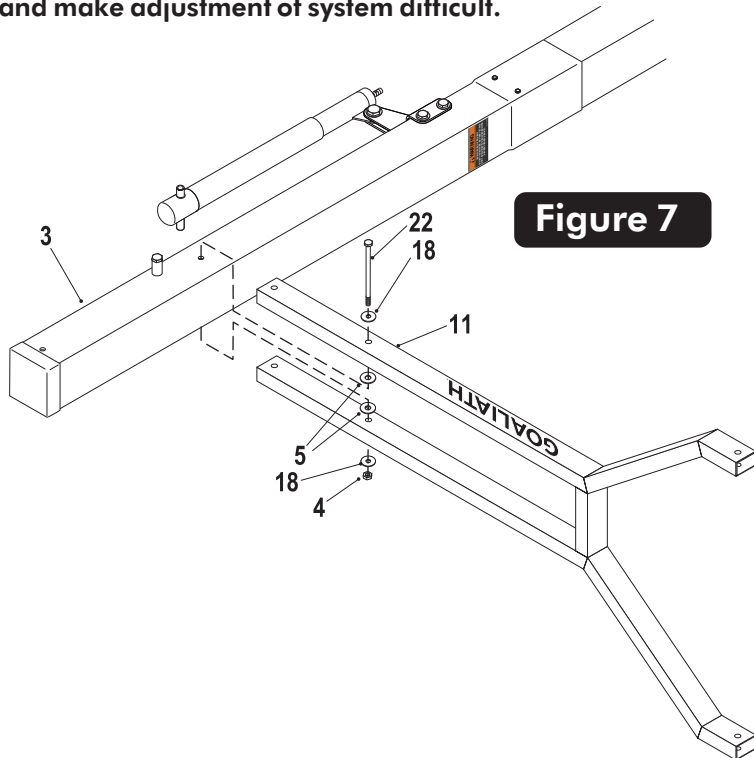
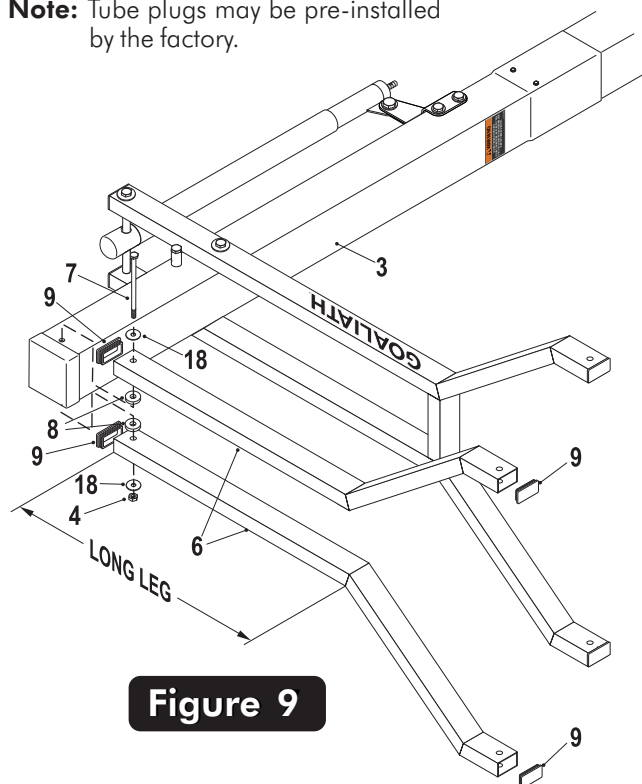

**Figure 7**

**10.** Secure Actuator (#16) to Lower Arms (#11) using one bolt (#22), two flat washers (#18), two plastic washers (#5) and one lock nut (#4). See **Figure 8**. Tighten both bolts (#22) **snug but, do not over tighten. Board Arms must pivot freely.**

**11.** Insert four Tube Plugs (#9) into open ends of Lower Arms (#11). It may be necessary to use a rubber mallet to tap them in.

**Note:** Tube plugs may be pre-installed by the factory.

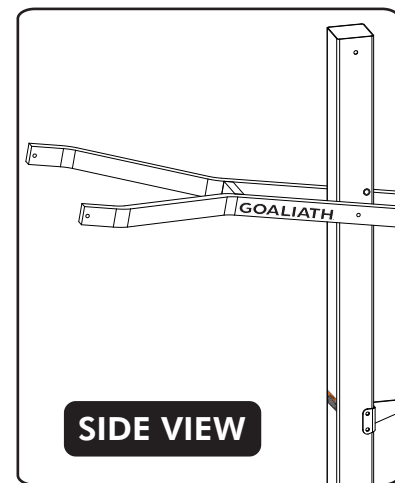

**Figure 9**

**9.** Attach lower arms (#11) to Top Pole (#3), as shown in **Figure 7**, using a hex bolt (#22), two flat washers (#18), two plastic washers (#5) and lock nut (#4).

**Note: Small amounts of clear tape can be used to adhere Plastic Washers (#5) to Pole. This will make assembly easier.**

**Note: make sure lettering is right side up. (See Side View). DO NOT tighten bolt (#22) at this time. (See Figure 7.)**



**SIDE VIEW**

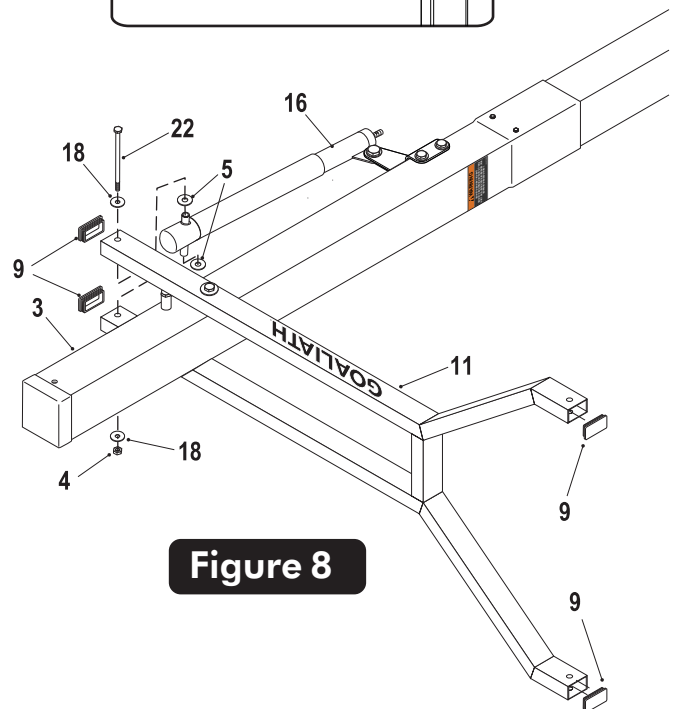

**Figure 8**

**12.** Attach long leg of Upper Arms (#6) to Top Pole (#3), as shown in Figure 9, using a bolt (#7), two flat washers (#18), two spacers (#8) and one lock nut (#4).

**Note: Tighten bolts snug but, do not over tighten. Board Arms must pivot freely.**

**13.** Insert four Tube Plugs (#9) into open ends of Upper Arms (#6). It may be necessary to use a rubber mallet to tap plug in. See **Figure 9**. **Note:** Tube plugs may be pre-installed by the factory.





**PLACING THE POST ON THE ANCHOR SYSTEM REQUIRES AT LEAST FOUR CAPABLE ADULTS. POLE WILL WANT TO LEAN WHILE ATTEMPTING TO STAND IT UP ON ANCHOR BOLTS.**

14. Locate hardware needed to mount pole to anchor bolts. You will need, eight flat washers (#37), four lock washers (#36), four hex nuts (#35) and four thread protectors (#34).

**Note: Do not remove the nuts you installed in step 2 (pg. 5).**

15. Put a flat washer (#37) on each anchor bolt. Lift post onto anchor system and secure with one flatwasher (#37), one lock washer (#36) and one hex nut (#35) for each anchor bolt. Tighten Fasteners finger tight, leave loose enough to level pole. Place a level on pole and adjust bottom nuts #35 until pole is level (left to right and front to back). **Tighten top four hex nuts #35 tight.** Place a thread protector (#34) on each anchor bolt. See **Figure 10.**

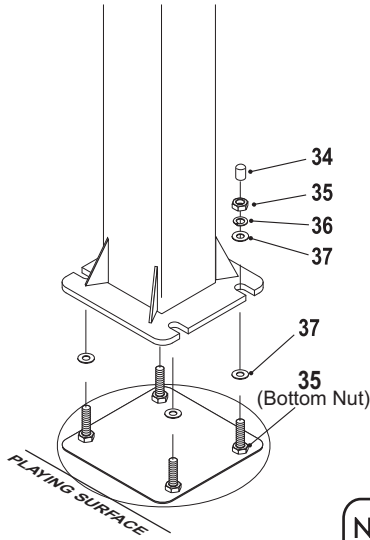

**Figure 10**

**BE SURE CONCRETE HAS BEEN ALLOWED TO CURE FOR AT LEAST 3 DAYS**

**Note: Bottom nuts #35 can be used for leveling system. See Step 14.**

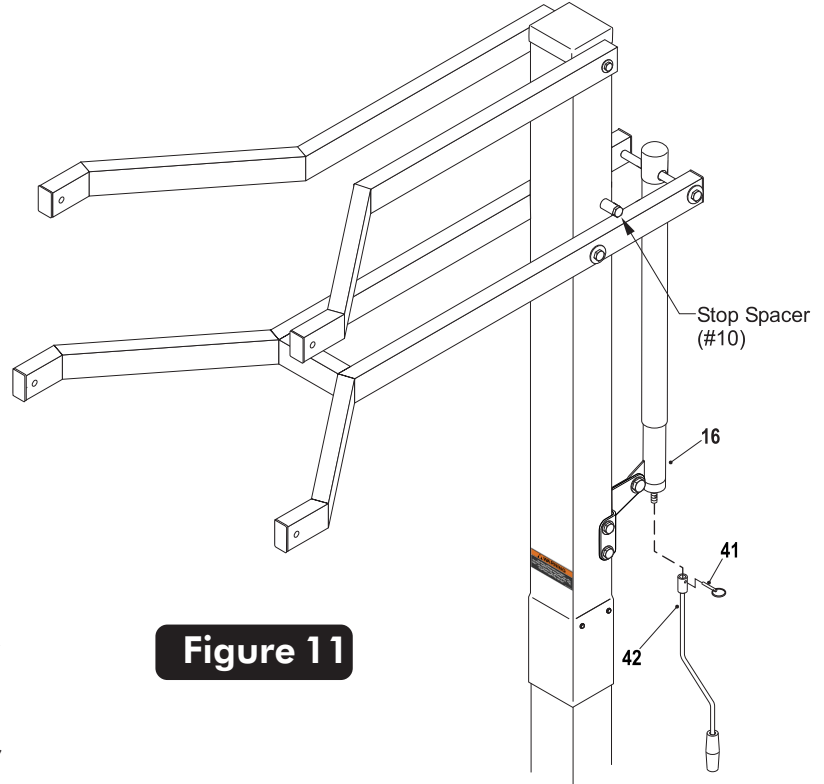

**Figure 11**

16. Slide Actuator Crank (#42) onto shaft on the bottom of Actuator (#16). Line up hole in shaft with hole in Actuator Crank and insert Pin (#41) to secure. See Figure 11.

17. To aid in the assembly of the backboard, lower the backboard, by turning the Actuator Crank, until the lower arm makes contact with Stop Spacer (#10).

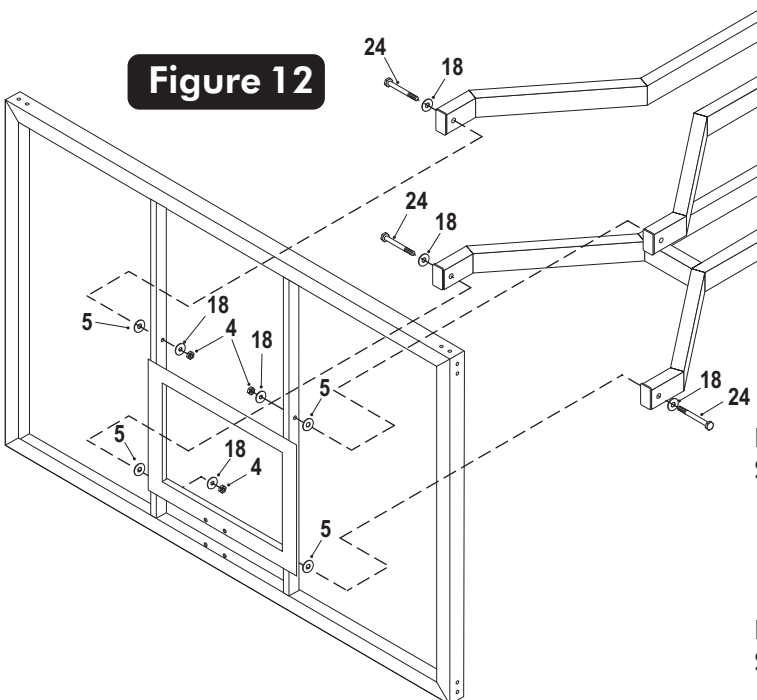

**Figure 12**



**ATTACHING BACKBOARD TO BOARD ARMS REQUIRES AT LEAST FOUR CAPABLE ADULTS.**

18. With at least three capable people, raise the backboard assembly up and have the fourth attach Lower Board Arms to lower mounting tubes on backboard using two bolts (#24), two plastic washers (#5), four washers (#18) and two lock nuts (#4). See Figure 12.

**NOTE: DO NOT over tighten these bolts. This is a pivot point. Snug is tight enough.**

19. Attach Upper Board Arms to upper mounting tubes on backboard using two bolts (#24), two plastic washers (#5), four washers (#18) and two lock nuts (#4). See Figure 12.

**NOTE: DO NOT over tighten these bolts. This is a pivot point. Snug is tight enough.**

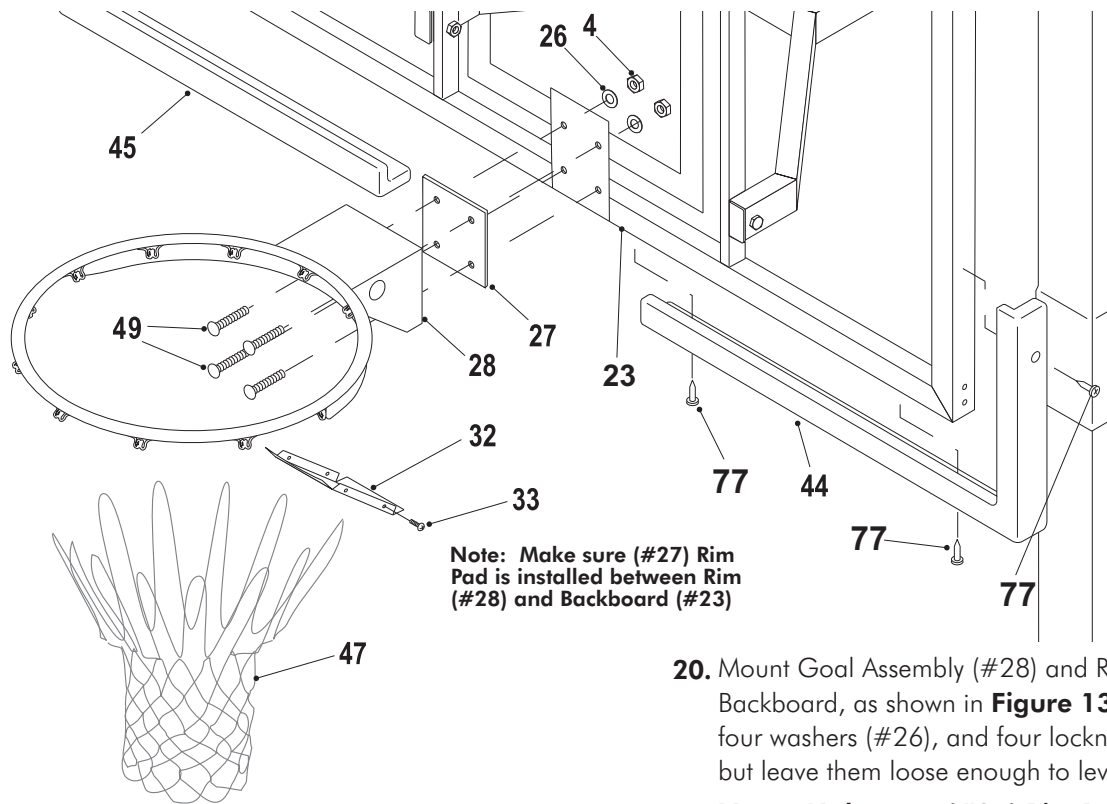
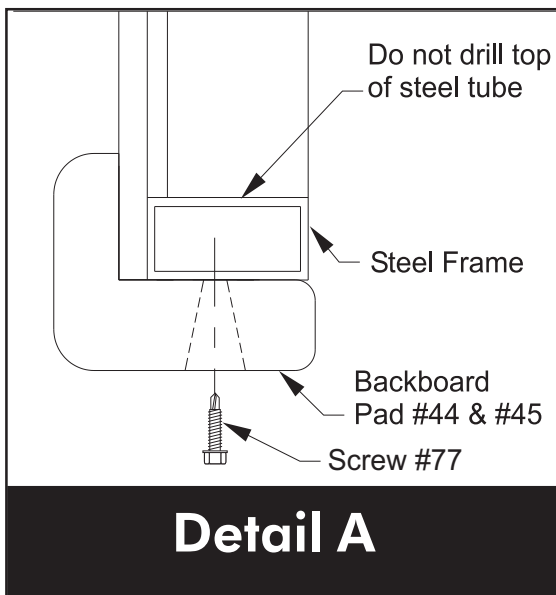

**Figure 13**

20. Mount Goal Assembly (#28) and Rim Pad (#27) to Backboard, as shown in **Figure 13**, using four bolts (#49), four washers (#26), and four locknuts (#4). Tighten fasteners, but leave them loose enough to level rim.

**Note: Make sure (#27) Rim Pad is installed between Rim (#28) and Backboard (#23)**

21. Place a level across rim assembly and adjust rim until it is level. Finish tightening the four nuts.



**⚠ CAUTION ⚠**

**NEVER USE RIM WITH COVERPLATE REMOVED!**

22. Attach Rim Cover Plate (#32) using four screws (#33). See Figure 13.

23. Check all nuts and bolts and make sure everything is tightened properly. **DO NOT over tighten** pivot points, snug is tight enough.

24. Use the Backboard Pads (#44) and (#45) as a template and mark the hole locations on the backboard frame. See Figure 13 and Detail A.

**Note: Screws (#42), used in step 25, are Self Drilling screws and can be installed without drilling pilot holes. However, it will be easier to install screws if you drill 9/64" pilot holes. WEAR SAFETY GLASSES if drilling holes.**

25. Drill 9/64" pilot holes into steel backboard frame. See **Detail A. Do not drill through both sides of tube.**

**Note: Cordless drill recommended for screw installation. Do not over tighten screws causing screws to strip.**

**Note: To install screws, it will be easier if you use a cordless drill with 5/16" socket (instead of Phillips head).**

26. Secure Backboard Pads (#44) and (#45), as shown, using screws (#77). Note: Tighten screws tight but, **do not over tighten.**

27. Raise Backboard to 10 FT. regulation playing height. Measure from top of rim straight down to the playing surface.

28. Using tape - mark the **side** of the steel actuator (#16) just under the plastic actuator sleeve (#15) at this 10 ft rim height. See **Figure 14**.

29. Lower backboard all the way down. Do not force actuator once backboard is in it's lowest position. See **Figure 15**.

30. **Do not** remove adhesive backing from height decal (#17) yet. Carefully place height decal on backside of steel actuator (#16) and line up the 10 ft mark on the tape with the 10 ft mark on the height decal. Decal should fit correctly onto the backside of the steel actuator. ( If not , simply trim to fit the top of the actuator decal).

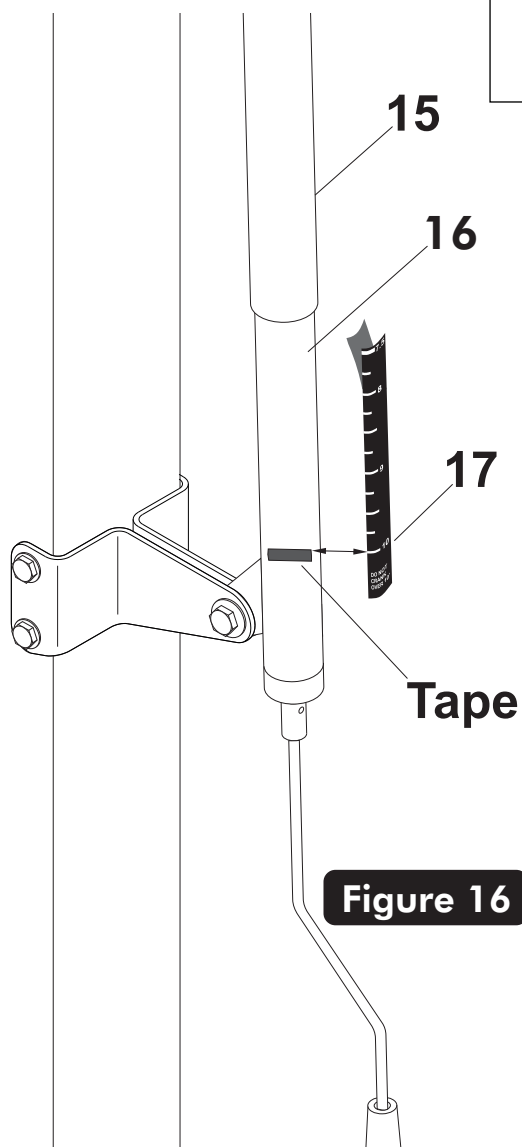
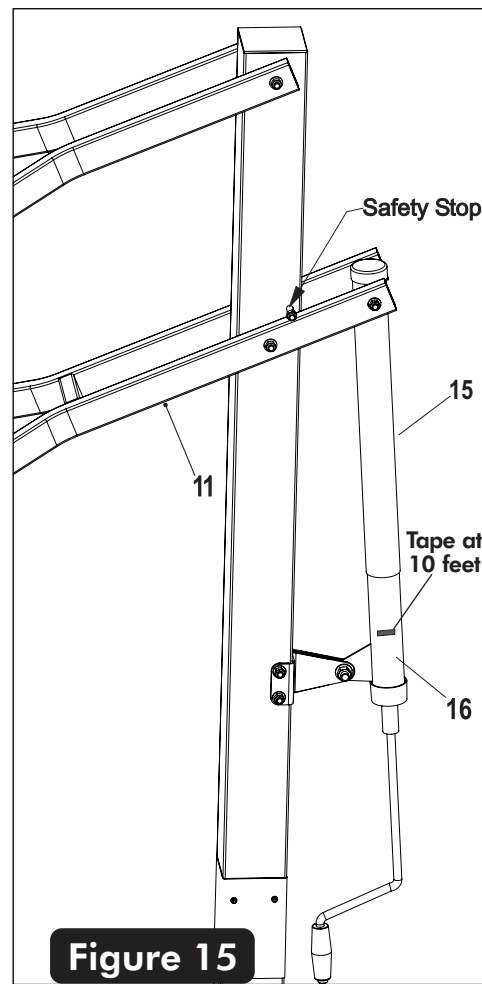
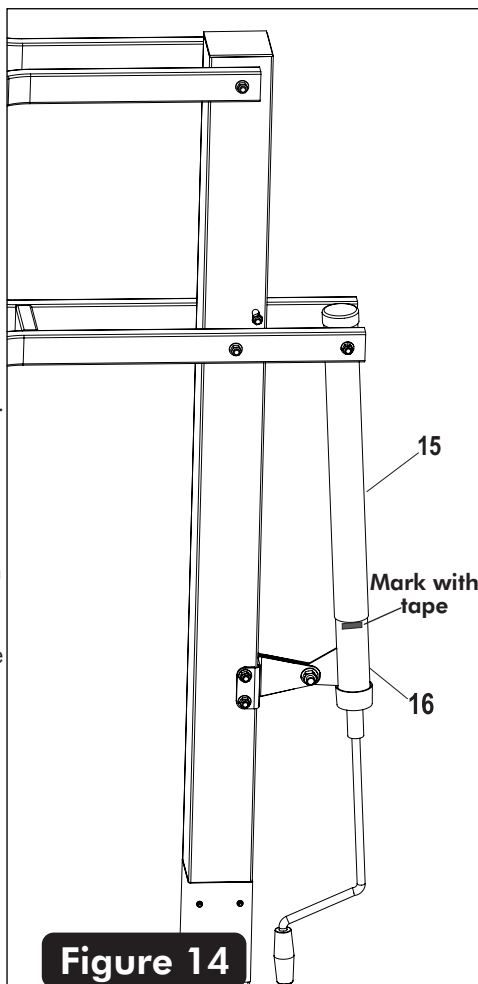

31. Remove the adhesive backing from the Height Decal (#17). Next, carefully align and stick decal to backside of steel actuator (#16) starting at the **10 ft mark first**. Be sure to keep the height decal straight and rub out all air bubbles. See **Figure 16**.

**Two adults are recommended for this step, one to level and one to adjust the bottom #35 nuts.**

- 32.** If further leveling is required loosen top #35 nuts but do not loosen past the top of #39 "J" Bolt. **DO NOT REMOVE NUTS #35.** Place a level on pole and adjust bottom nuts #35 with a 15/16" open end wrench until pole is level. Tighten top #35 hex nuts. See Detail B.

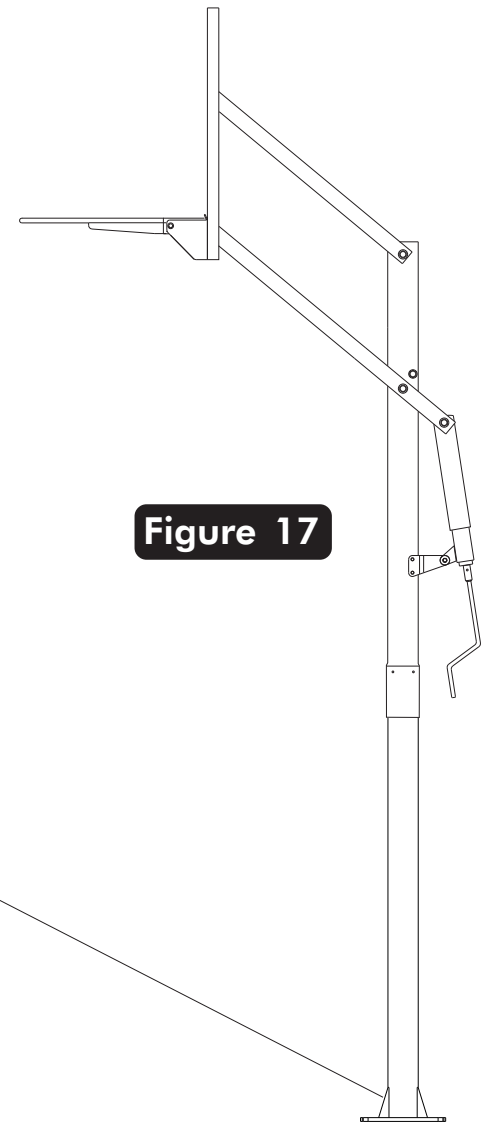
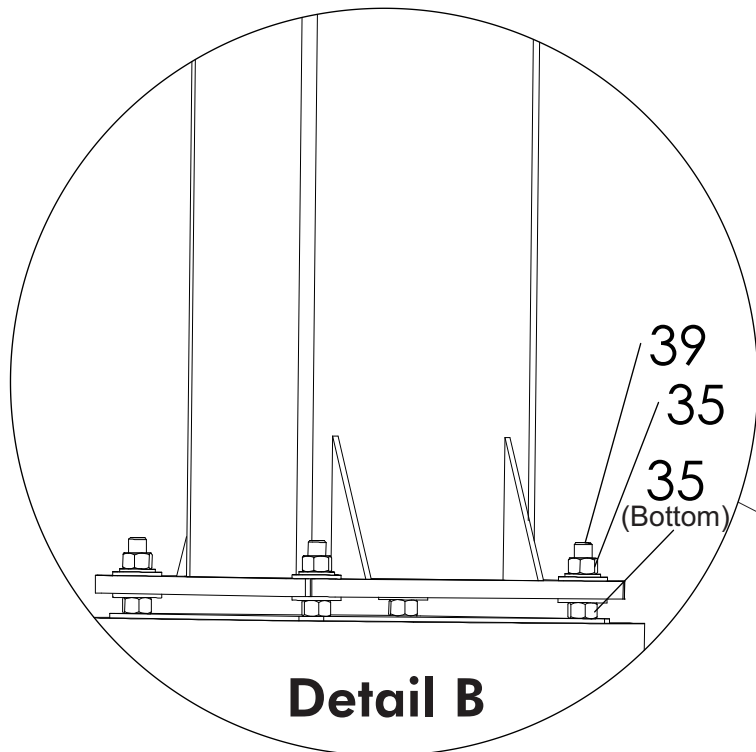

## LIMITED 5 YEAR WARRANTY

This consumer warranty extends to the original consumer purchase of any Escalade® Sports Product (hereinafter referred to as the "Product").

**WARRANTY COVERAGE:** Escalade® Sports warrants to the original Consumer Purchaser that any Product of its manufacture is free from defects in material and workmanship. THIS WARRANTY IS VOID IF THE PRODUCT HAS BEEN DAMAGED BY ACCIDENT, UNREASONABLE USE, NEGLIGENCE, IMPROPER SERVICE, FAILURE TO FOLLOW INSTRUCTIONS PROVIDED WITH THE PRODUCT OR OTHER CAUSES NOT ARISING OUT OF DEFECTS IN MATERIAL OR WORKMANSHIP.

Subject to proper installation and normal Residential use, Escalade® Sports warrants, subject to the limitations below, to the original retail purchaser all structural components of the Goaliath® System to be free of defects in material and workmanship for a period of five (5) years from the original purchase.

Merchandise must be shipped prepaid with a copy of proof of purchase to Escalade® Sports factory for examination to determine if the basketball system needs to be repaired or replaced. Any labor costs, travel expenses and any other changes involved in the removal, installation or replacement of the defective/repaired parts from/to your Goaliath® System will be the purchaser's responsibility. Shipping charges for replaced or warranted merchandise sent back to the customer from Escalade® Sports factory must be prepaid by the customer in advance. If not, the replacement shipment will be sent out collect.

Escalade® Sports reserves the right to examine photographs or physical evidence of merchandise claimed to be defective, and to recover said merchandise, prior to authorization of warranty claims. A "Returned Goods Authorization" number may be required, please call for details prior to the return of any photographs or merchandise.

This limited 5 year warranty is expressly in lieu of all warranties, expressed or implied, including warranties of merchantability or fitness for use. Escalade® Sports does not assume or authorize any person or representative to assume for us, any other liability in connection with the sale of our products.

The remedy of repair or replacement stated above is Escalade® Sports exclusive remedy. Escalade® Sports will not be liable for any other damages or expenses which may incur, including but not limited to incidental or consequential damages. Escalade® Sports assumes no other obligations or liability on the part of the purchaser, and Escalade® Sports neither assumes nor authorizes any other person to assume for it any other liability in connection with the goods sold.

This warranty shall not apply in any manner to parts or accessories not manufactured by Escalade® Sports.

### NOT COVERED BY THIS WARRANTY

- Merchandise not intended to be in places of public assembly, such as, but not limited to, schools, parks, public or private recreational facilities.
- Any merchandise subjected to Non-residential abuse, negligence, improper installation, vandalism, acts of God, alteration of product, or any other events beyond the control of Escalade® Sports.
- Paint or rusted parts. If rust should appear, remove loose paint, sand lightly, primer and paint with exterior flat matte finish enamel paint.
- HANGING ON RIM WILL VOID THE WARRANTY: Rims are not warranted for any defects other than workmanship. Torn back plates, damaged springs, bent rings, damaged eyebolts, and torn or distorted rim supports result from hanging on the rim and are not warranted.
- Shipping charges both ways. Note: Any merchandise shipped to Escalade® Sports collect will be refused.
- Dealer service charges, labor charges and travel expenses associated with replacement of repair of warranty item.

**WARRANTY DISCLAIMERS:** ANY IMPLIED WARRANTIES ARISING OUT OF THIS SALE, INCLUDING BUT NOT LIMITED TO THE IMPLIED WARRANTIES OF MERCHANTABILITY AND FITNESS FOR A PARTICULAR PURPOSE, ARE LIMITED IN DURATION. ESCALADE® SPORTS SHALL NOT BE LIABLE FOR LOSS OF USE OF THE PRODUCT OR OTHER CONSEQUENTIAL OR INCIDENTAL COSTS. EXPENSES OR DAMAGES INCURRED BY THE CONSUMER OF ANY OTHER USE.

Some states do not allow the exclusion or limitation of implied warranties or consequential or incidental damages, so the above limitations or exclusions may not apply to you.

LEGAL REMEDIES: This warranty gives you specific legal rights, and you may also have other rights which may vary from state to state.

### WARRANTY GUIDELINES IS REQUIRED FOR ALL WARRANTY CLAIMS

1. Proof of Purchase (original retail purchaser) is required for all warranty claims.
2. Call or write Escalade® Sports to receive a Return Authorization # and determine specific needs.

Phone: 1-888-USA-GOAL / Warranty Dept.

Or Write Escalade® Sports at: Escalade® Sports - P.O. Box 889, Evansville, IN 47706 - Attn: Warranty Dept.

Or E-mail us at: [basketball@escaladesports.com](mailto:basketball@escaladesports.com)

## GOALIATH CARE INFORMATION

### - BACKBOARD -

**Items needed to clean backboard:**

- 100% cotton soft cloth, (only)
- Glass Cleaner

Clean backboard using a **100% Cotton** soft cloth and glass cleaner. Clean glass as you would household windows. Strong cleansers will damage backboard and void warranty.

### - RIM -

**HANGING ON THE RIM WILL VOID YOUR WARRANTY.** Rims are not warranted for any defects other than workmanship. Torn back plates, damaged springs, bent rings, damaged eye bolts, and torn or distorted rim supports result from hanging on the rim and are not warranted.

The goal should not be cranked under 7-1/2' or over 10'. Adjustments of the goal should be done under adult supervision.

When attempting slam dunk activity you should always wear a mouth guard to avoid dental injury.

### - MAINTENANCE -

To ensure ease of operation, lubricate all pivot points at least every 6 months or as needed with a good lubricant such as WD-40.

### - RUST -

Inspect your pole periodically, if rust should appear, remove loose paint, sand lightly, primer and paint with exterior flat matte finish enamel paint.

## B2251 REPLACEMENT PARTS LIST

Key#	Part #	Description	Qty.
1	3M-6850-00	4" Square Tube Plug	1
2	1A-7686-01	Bottom Post	1
3	8S-6898-00	Top Post	1
4	901-28	3/8-16 Nylon Lock Nut	14
5	3M-6883-00	1-1/4" OD Plastic Washer	8
6	8S-6630-02	Upper Board Arm	2
7	1B-6483-10	3/8-16 X 7.5" Hex Bolt-Grade 5	1
8	3M-6269-00	1/4" Spacer	2
9	3M-6548-00	1 X 2 Tube Plug	8
10	8S-6657-00	Stop Spacer	2
11	1A-6331-02	Lower Board Arm	1
12	Not Used		
13	3M-6467-00	Actuator Cap	1
14	8S-6658-00	Pivot Tube	1
15	3M-6542-00	Actuator Sleeve	1
16	4A-6605-00	Actuator	1
17	4L-7501-00	Height Decal	1
18	701-50	3/8 STD Washer	18
19	1B-6486-10	1/2-13 X 1-1/2" Hex Bolt	1
20	2B-6093-00	1/2 Flat Washer	2
21	2B-6095-00	1/2-13 Nylon Lock Nut	1
22	1B-6484-10	3/8-16 X 7" Hex Bolt-Grade 5	3
23	6A-7548-00	Backboard Assembly-33x54" Glass	1
24	1B-6195-00	3/8-16 X 2.75" Hex Bolt	4

Key#	Part #	Description	Qty.
25	1B-6485-10	3/8-16 X 5" Hex Bolt	2
26	2B-6114-00	3/8 Flat Washer	4
27	3M-6473-00	3X4 Rim Pad	1
28	6A-6374-01	Goal Assembly	1
29	3M-6835-00	Goal Spacer Plate (Pre-Installed)	1
30	2S-6795-02	Post Ear	2
31	NOT USED		
32	2S-6427-01	Rim Cover Plate	1
33	1B-6788-00	#8 x 1/2 Thread Forming Scr.	4
34	3M-6469-00	5/8 Thread Protector	4
35	2B-6097-00	5/8-11 Hex Nut	12
36	2B-6099-00	5/8 Split Lockwasher	4
37	2B-6098-01	5/8 SAE FLAT WSHR ZNC	8
38	2S-6453-00	Anchor Template	1
39	2B-6112-00	5/8-11 X 14 "J" Bolt	4
40	1S-6167-00	#3 X 30" Rebar	4
41	7B-6255-00	Pull Pin	1
42	4A-6606-00	Actuator Handle	1
43	2L-7539-00	This Manual	1
44	3M-6580-00	48" Board Pad Right	1
45	3M-6581-00	48" Board Pad Left	1
46	Not Used		
47	3F-6010-00	Net	1
48	Not Used		
49	1B-6782-00	3/8-16 x 1 3/4" Carriage Bolt	4
50	Not Used		
77	1B-7039-00	Self Tapping Screw-#10 x 1"	10

