

BLACK DIAMOND[®]

Project Name: _____

Location: _____

Item #: _____

Qty: _____

Black Diamond Refrigerated Pizza Prep Table, 3 Doors, 26.6 Cu. Ft., in Stainless Steel

GRPZ-3D



Boost your commercial kitchen's productivity with the Black Diamond Refrigerated Pizza Prep Table. Featuring a robust stainless steel exterior and a painted aluminum interior, this unit ensures durability and effortless cleaning. The 26.6 Cu. Ft. capacity provides generous storage for ingredients, while precise digital controls and an eco-friendly R290 cooling system maintain reliable temperatures between 33° and 40°F. Equipped with three adjustable shelves and self-closing doors, it streamlines organization and workflow. Auto defrost simplifies maintenance. Designed for demanding foodservice environments, this pizza prep table includes a two-year parts and labor warranty and a five-year compressor warranty.

FEATURES AND CONSTRUCTION

- Provides 26.6 Cu. Ft. of refrigerated capacity for storing large quantities of pizza ingredients
- Equipped with a 0.75 horsepower side-mounted compressor for fast, efficient cooling
- Features a durable stainless steel exterior and painted aluminum interior for lasting performance and easy sanitation
- Maintains a precise temperature range of 33° to 40°F for safe storage of perishable items
- Operates on eco-friendly R290 refrigerant
- Includes three solid self-closing doors with recessed handles for secure cold retention and convenient operation
- Comes with three adjustable, plastic-coated steel shelves for versatile ingredient organization
- Mounted on four heavy-duty 4-inch casters, including two locking, for maximum mobility and stability
- Polyethylene cutting board included for convenient prep work

ELECTRIC

115VV / 60Hz / 1Ph

Cord Length (Inches): 98.40"

Plug Type: NEMA 5-15P

Cord set included

NEMA 5-15P



3RD PARTY APPROVALS



WARRANTY (USA / CANADA)

Two (2) Year Limited Warranty on Parts and Labor, Five (5) Year Warranty on Compressor and Evaporator

Contact us for details at 1.877.368.2797



STORAGE CAPACITY

- Cubic Feet: 26.6 Cu. Ft.

TEMPERATURE

- Holding Temperature (Fahrenheit): 33° - 40°
These models are designed to operate in an environment where temperature and humidity do not exceed 75°F (24°C) and 55% relative humidity



Black Diamond Refrigerated Pizza Prep Table

GRPZ-3D

FRONT

SIDE

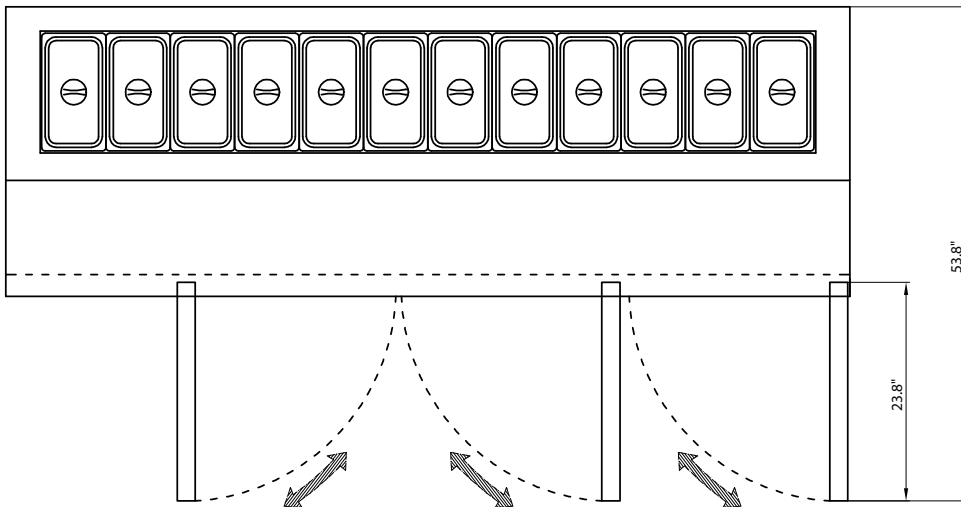
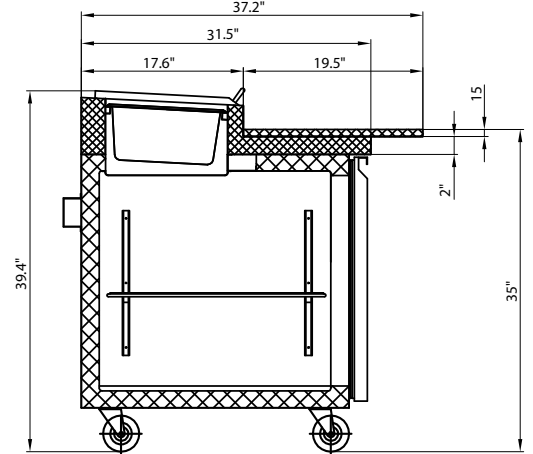
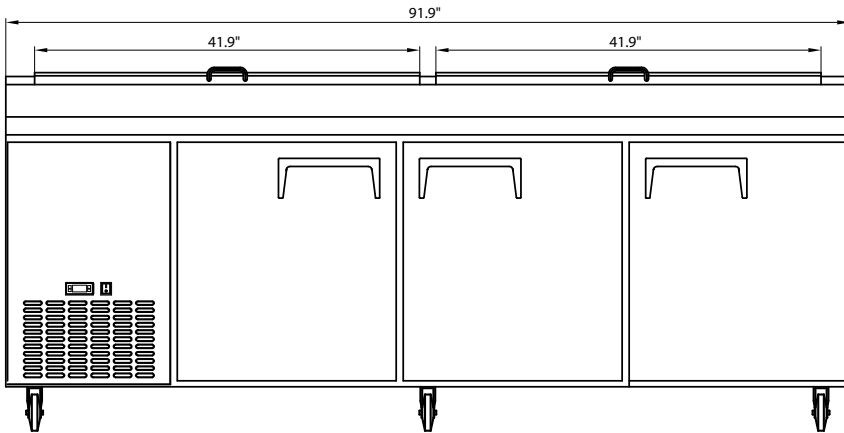

TOP

Prep Table

Doors	Shelves	Amps	HP	Refrigerant	Capacity	Assembled Dimensions (in)	Item Weight (lbs)	Shipping Weight (lbs)
3	3	6.6A	1/4	R290 3.883	26.6 Cu. Ft.	91.90" x 31.50" x 39.40"	440.0	609.0

Due to periodic changes in designs, methods, procedures, policies and regulations, the specifications contained in this document are subject to change without notice. While we exercise good faith efforts to provide information that is accurate, we are not responsible for errors or omissions in information provided or conclusions reached as a result of using the specifications. By using the information provided, the user assumes all risks in connection with such use.