

ASSEMBLY INSTRUCTION

KITCHEN ISLAND

A TOP

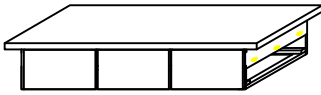

1 PC

B BOTTOM BOARD



1 PC

C LEFT LEG FRAME

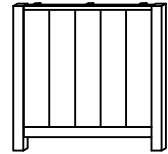

1 PC

D MIDDLE LEG FRAME

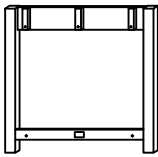

1 PC

E MIDDLE SUPPORT



1 PC

F MOVABLE SHELF

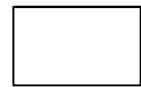

1 PC

G RIGHT PANEL

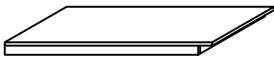

1 PC

H RIGHT LEG FRAME

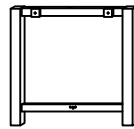

1 PC

I RAIL



1 PC

J BOLT
Ø1/4x5/8"



4 PCS

K BOLT
Ø1/4x1-1/4"



5 PCS

L SPRING WASHER
Ø1/4"



8 PCS

M FLAT WASHER
Ø1/4"



4 PCS

N ALLEN WRENCH
Ø1/4"



5 PCS

O SHELF SUPPORT
29x17x13mm



8 PCS

P CONNECTING METAL
32X22X18X1.5mm



8 PCS

Q BOLT
Ø5/16"x1-1/2"

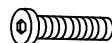

1 PC

R BOLT
Ø5/16"x2"

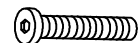

4 PCS

2 PCS

13 PCS

3 PCS

S SPRING WASHER
Ø5/16"



16 PCS

T FLAT WASHER
Ø5/16"



16 PCS

U ALLEN WRENCH
Ø5/16"



1 PC

V BOLT
Ø5/16"x3-1/4"



1 PC

W HALF MOON SCREW
NUT
Ø5/16"



1 PC

X SCREW NUT
Ø5/16"



1 PC

Y SPANNER
Ø5/16"



1 PC

Z METAL HANDLE
185x11x34mm

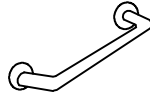

3 PCS

A1 SCREW
#8x1"



6 PCS

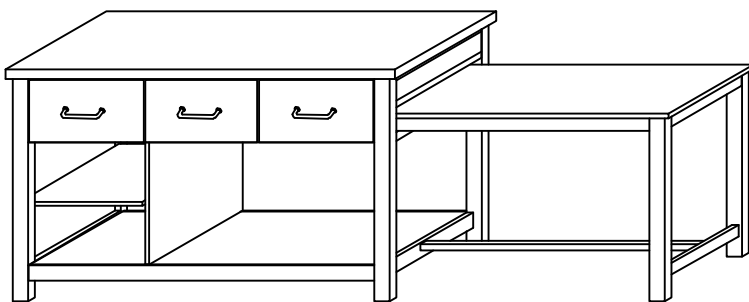

This page lists all the contents included in the box.

Please take the time to identify the hardware as well as the individual components to this product.

As you unpack and prepare for assembly, place the contents on a carpeted or padded area to protect them from damage.

*** Do not tighten screws & bolts until the entire unit is completely assembled.

1 Attach left leg frame(C) and middle leg frame(D) to top(A) by using bolt(Q), spring washer(S), flat washer(T) and allen wrench(U) as shown.

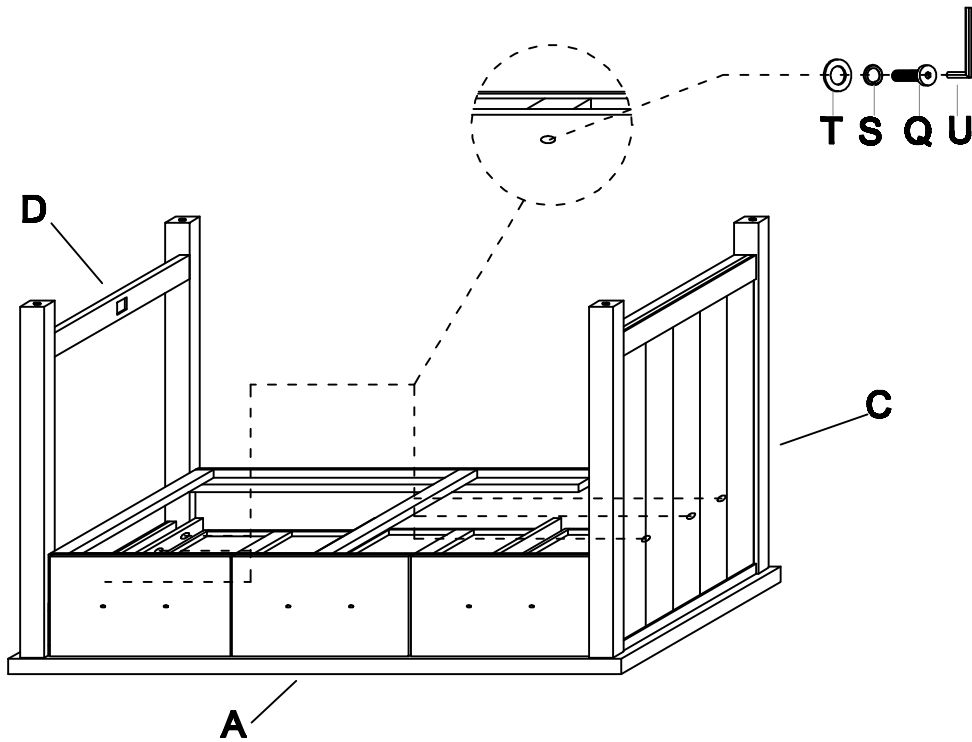

2 Attach middle support(E) to top(A) by using connecting metal(P), bolt(J), spring washer(L), flat washer(M) and allen wrench(N) as shown.

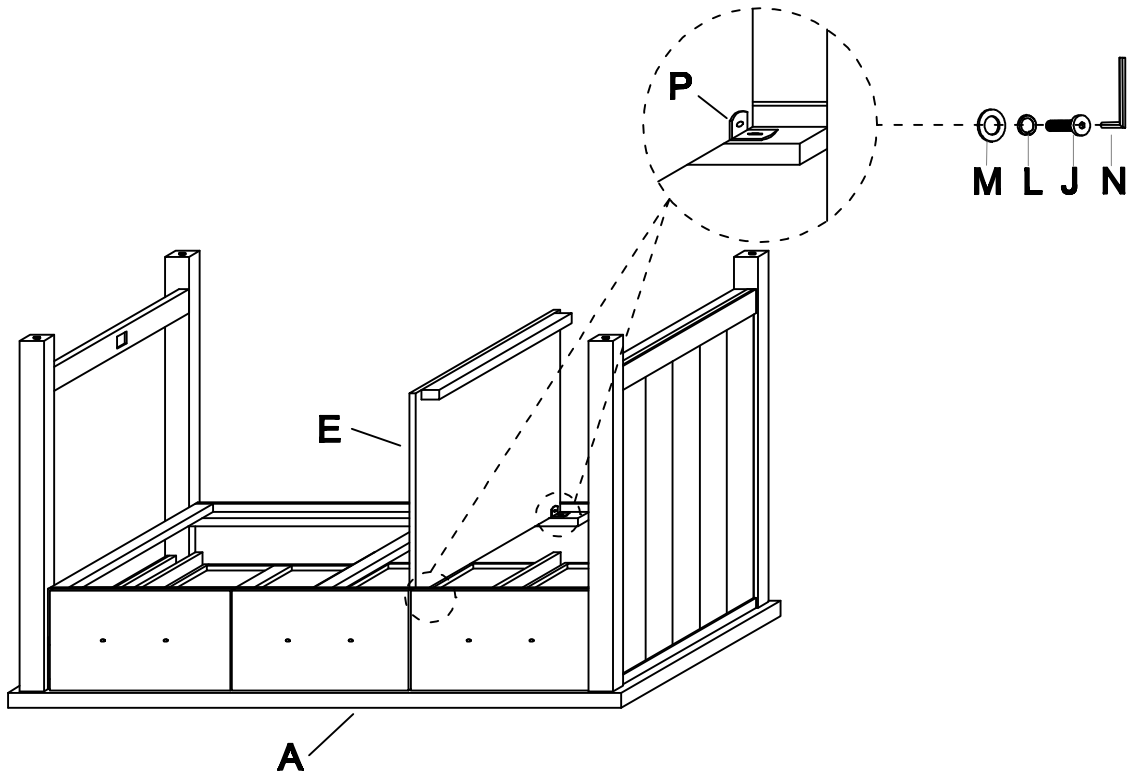

*** Do not tighten screws & bolts until the entire unit is completely assembled.

3 Attach bottom board(B) to left leg frame(C), and middle leg frame(D) by using bolt(Q), spring washer(S), flat washer(T), and allen wrench(U) as shown. Attach bottom board(B) to middle support(E) by using bolt(K), spring washer(L), flat washer(M), and allen wrench(N) as shown.

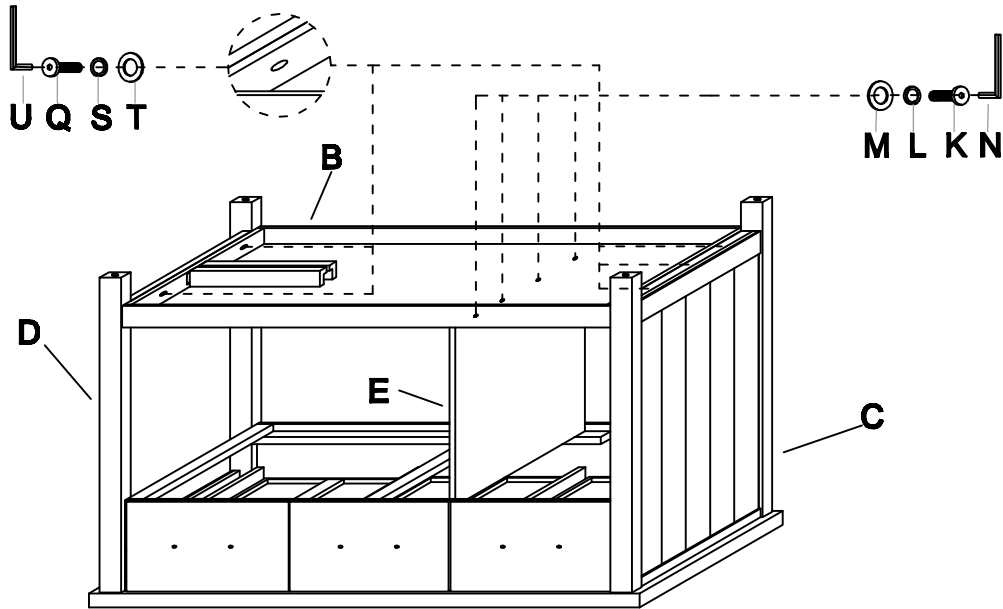

4 Attach movable shelf(F) to left leg frame(C) and middle support(E) by using shelf support(O) as shown.

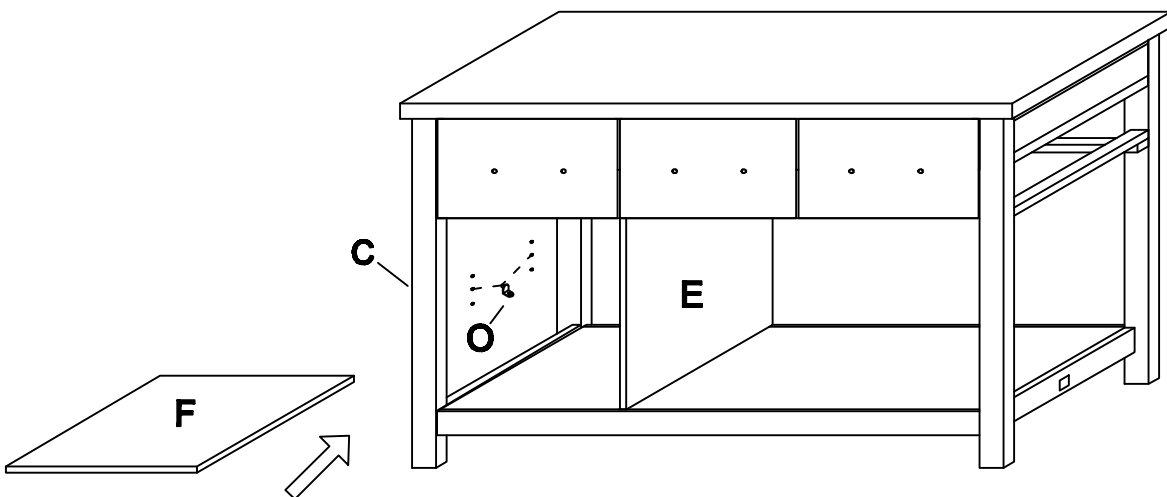

*** Do not tighten screws & bolts until the entire unit is completely assembled.

5 Attach right leg frame(H) to right panel(G) by using bolt(Q), bolt(R), spring washer(S), flat washer(T) and allen wrench(U) as shown.

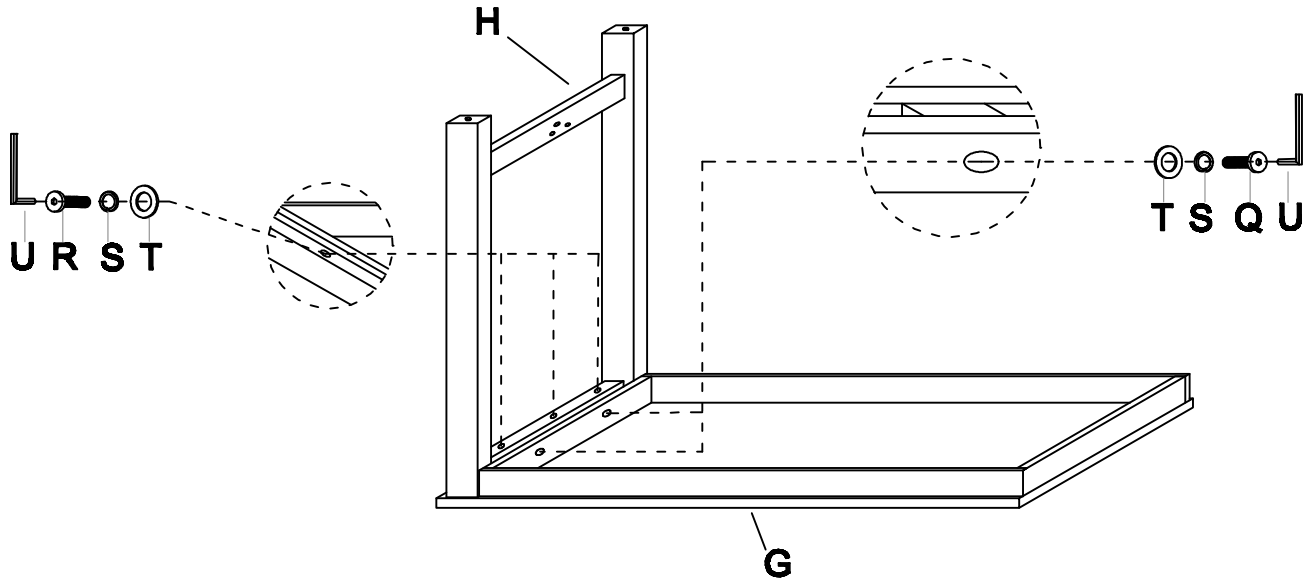

6 Attach rail(I) to right leg frame(H) by using bolt(V), half moon screw nut(W), screw nut(X) and spanner(Y) as shown.

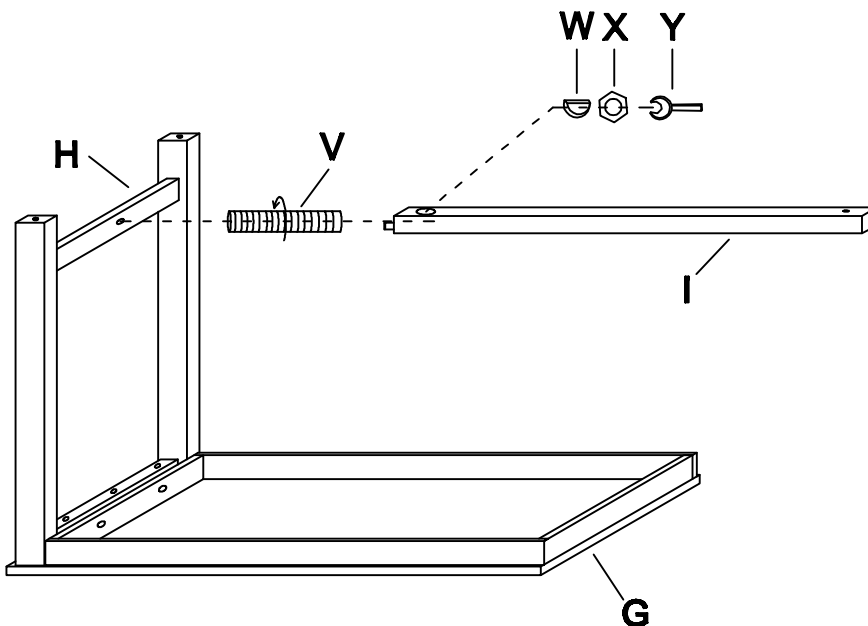

*** Do not tighten screws & bolts until the entire unit is completely assembled.

7 Attach right panel(G) and rail(I) to middle leg frame(D) as shown. Attach bolt(K) to rail(I) by using allen wrench(N) as shown.

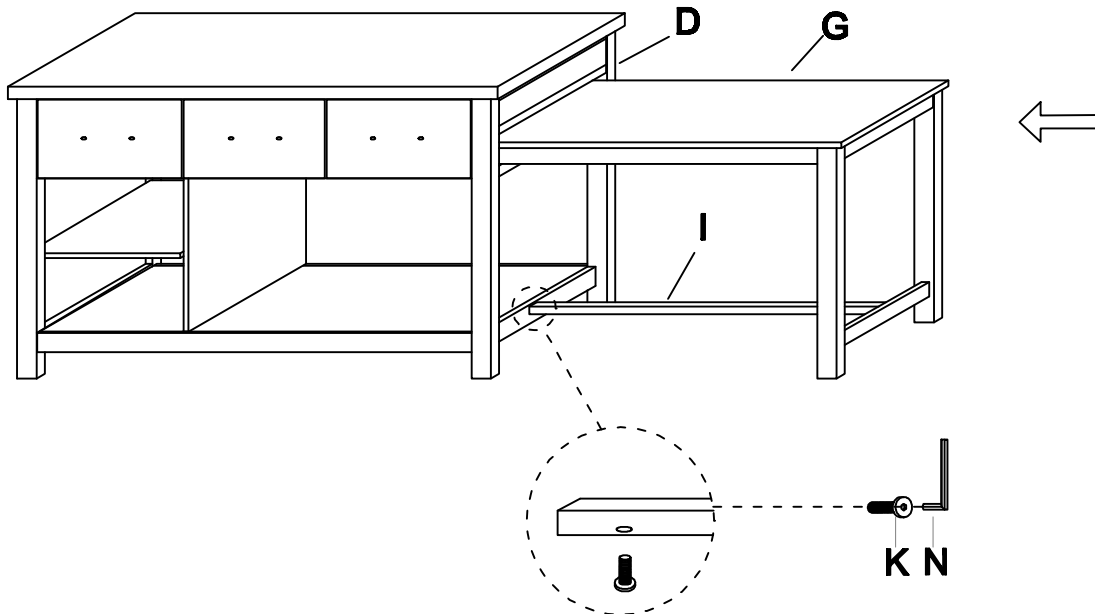

8 Attach metal handle(Z) to top(A) by using screw(A1) as shown.

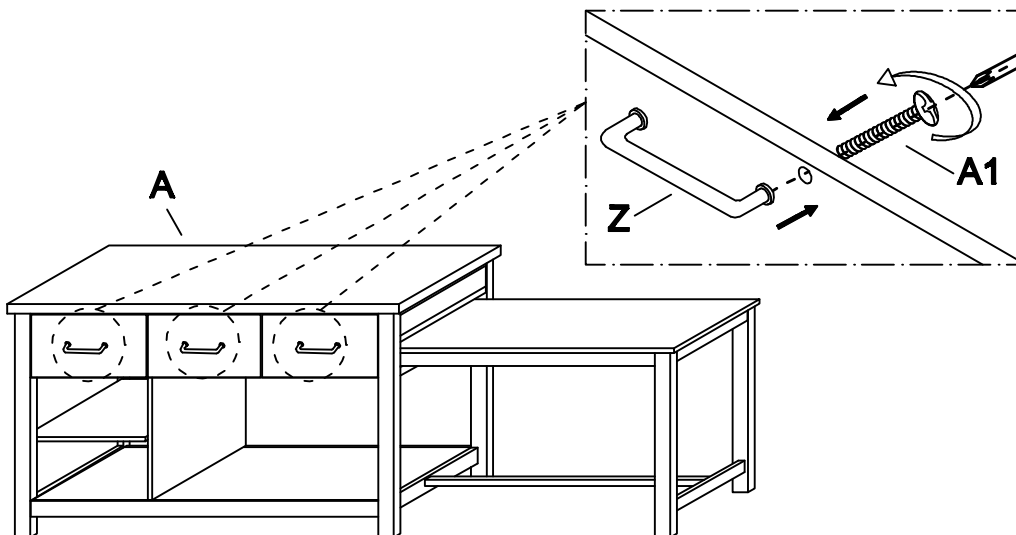

Cleaning & Care

Treat surface with care. Surface is resistant to scratches but is not scratch resistant. Clean surfaces with a dry or damp soft cloth. Do not use abrasive cleaners. Hardware may loosen over time. Periodically check that all connections are tight.