

① 020-0405-R495
FINISH HEIGHT=.547 [13.89]

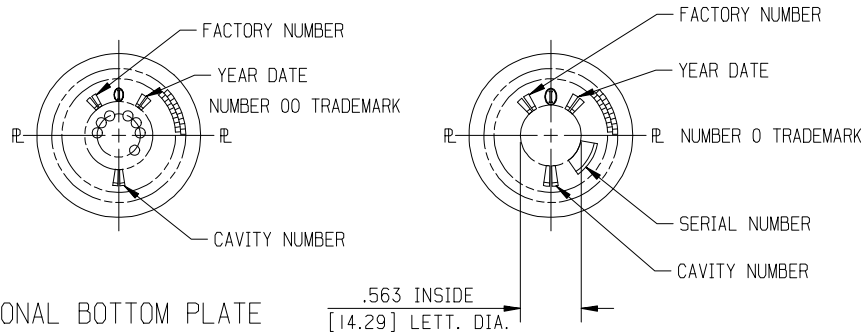
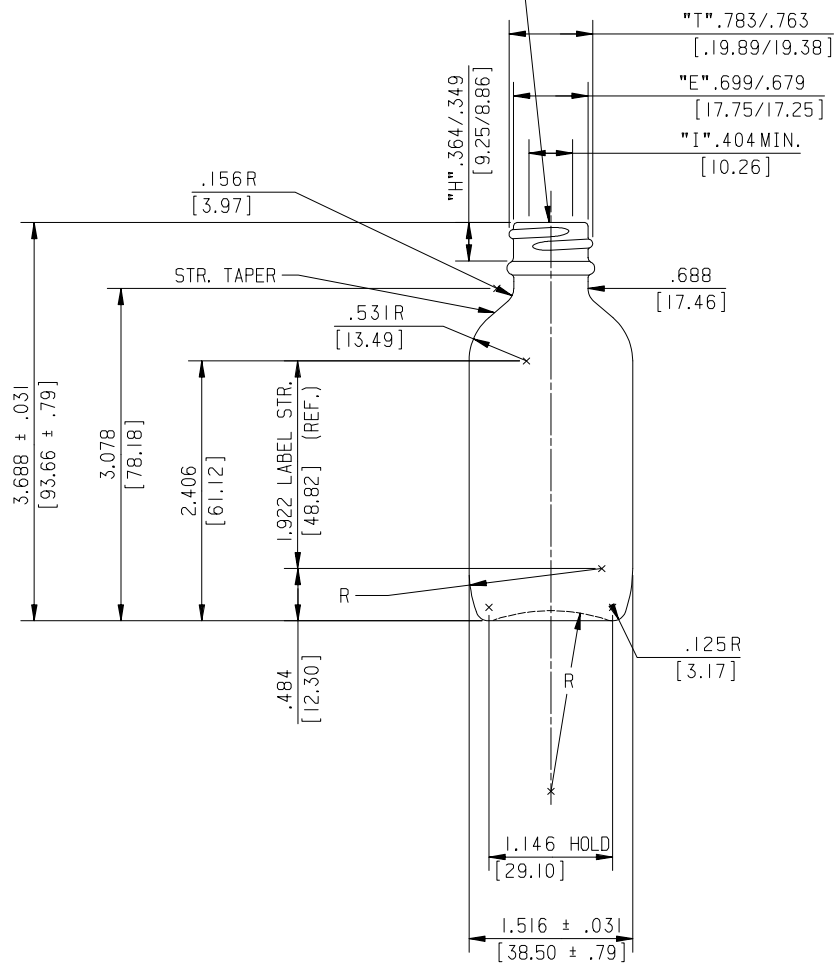

OPTIONAL BOTTOM PLATE
FOR INSERTED MOLDS

① THESE FINISH DIMENSIONS ARE BASED ON THE CURRENT FINISH SPECIFICATIONS AS OF THE ISSUE DATE OF THIS DRAWING.

BOTTOM PLATE LETTERING TO BE .156 [3.97] TALL EXCEPT CAVITY NUMBER TO BE .188 [4.76] TALL.

OPTIONAL BOTTOM PLATE LETTERING TO BE .125 [3.18] TALL EXCEPT CAVITY NUMBER TO BE .156 [3.97] TALL.

OPTIONAL A.G.R. C.I.D. DOT CODE TO APPEAR ON BOTTOM PER GS-324

BPK-160 TO APPEAR ON BEARING SURFACE.

O'FLOW CAPACITY 2.172 FL. OZ. ± 0.063 FL. OZ. [64.23 ml ± 1.85 ml]

FILL POINT OVERFLOW

WEIGHT 2.000 oz. ± 0.125 oz. [56.70 g ± 3.54g]

DISCLAIMER

THIS INFORMATION IS PROVIDED AS A GENERAL GUIDE, INCLUDING DIMENSIONS. IT IS THE CUSTOMER'S RESPONSIBILITIES TO SELECT THE PROPER CONTAINER FOR PRODUCT AND APPLICATION COMPATIBILITY.

DISTRIBUTED BY:



REF NO.:

DWG 31273

DESCRIPTION:

2 oz Amber Boston Round, 20-400