

ASSEMBLY AND INSTALLATION INSTRUCTIONS

C0311 / C0312 / C0351

WARNING: TO AVOID RISK OF ELECTRICAL SHOCK, BE SURE TO SHUT OFF POWER WHILE INSTALLING OR SERVICING THIS FIXTURE.

NOTE: 1. Before installing, consult local electrical codes for wiring and grounding requirements.
2. Read and save this instructions.

Hardware Package (included):

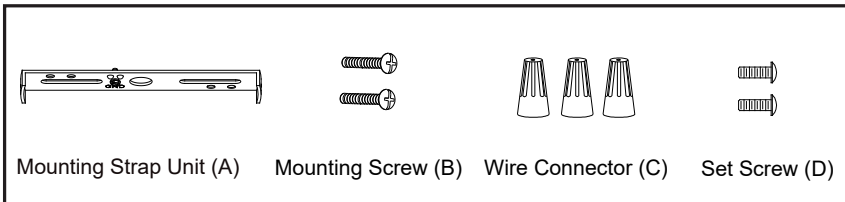

Installation Steps

Turn off the power at fuse or circuit box

1. Unscrew the two set screws (D) and separate the mounting strap unit (A) from the fixture.
2. Attach the mounting strap unit (A) to the outlet box by using two mounting screws (B).
3. Pull out the source wires from the outlet box. Make wire connections using wire connectors (C) as follows:
 - Connect the hot wire (black insulation) from the fixture to the black wire from the power source.
 - Connect the neutral wire (white insulation) from the fixture to the white wire from the power source.
 - Attach the fixture ground wire (green insulation or bare wire) to the mounting strap unit (A) with the green ground screw, then connect it to the house ground wire with the wire connector (C).Carefully put the wires back into the outlet box.
4. Attach the fixture to the mounting strap unit (A), and then secure it with two set screws (D).
5. Install 1 x 60W Max. medium base bulb (not included). See relamping label at socket area or packaging for maximum wattage allowed.
6. Attach the glass shade to the fixture, and then secure it with three fixture screws.

Turn on the power at fuse or circuit box

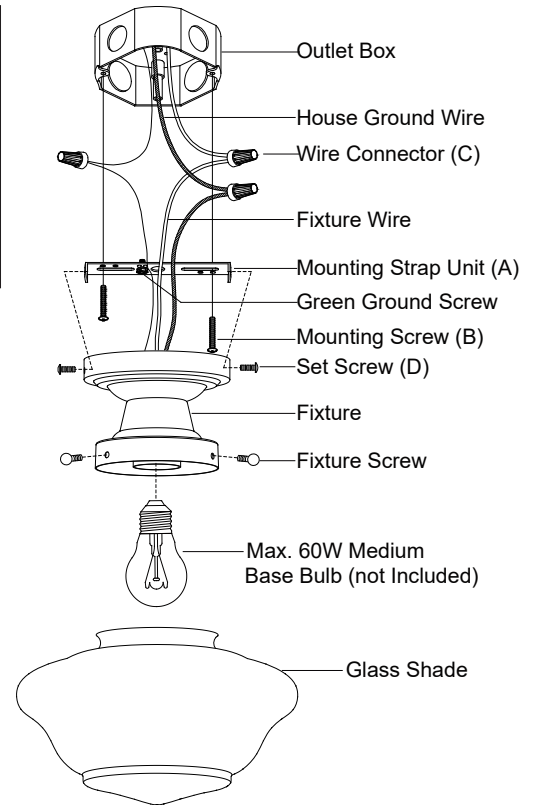

The following parts are available for reorder if damaged or missing.

Spare Parts List:



Mounting plate Unit (A)



Mounting Screw (B)

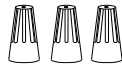

Wire Connector (C)



Set Screw (D)



Mounting Hardware
6836MM (1SET) for C0311
6837MM (1SET) for C0312
7174MM (1SET) for C0351

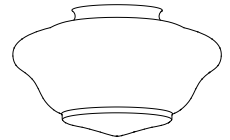

Glass Shade
10425OG

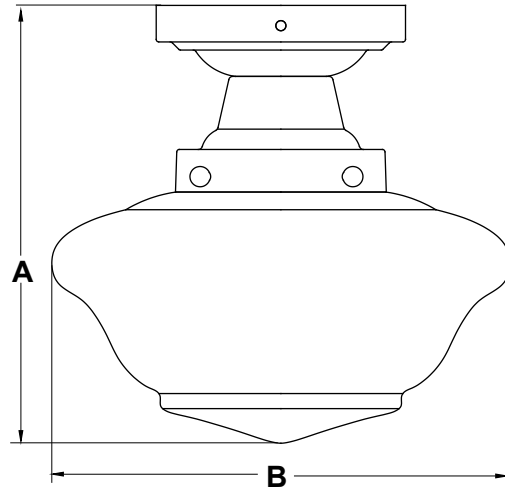

A: 8-1/2"

B: 8-3/4"

1 Year Warranty

Vaxcel warrants all of our products against defects in workmanship and finishes for one year following the date of shipment.

Exclusions: This warranty does not include the failure of products from extreme acts of nature; environmental conditions not suited for the products intended use; operation in temperatures outside of the range specified in the instruction manual; usage with improper power supply, power surges or dips. For coastal locations, some corrosion is considered normal for the environment.

Vaxcel reserves the right to repair, replace or issue a credit for any properly installed product, provided it is returned per RMA instruction. This warranty is limited to the cost of the product only and does not extend to transportation, installation or replacement costs.

How can warranty service be obtained?

info@vaxcel.com
1-800-482-9235