

4

3

2

1

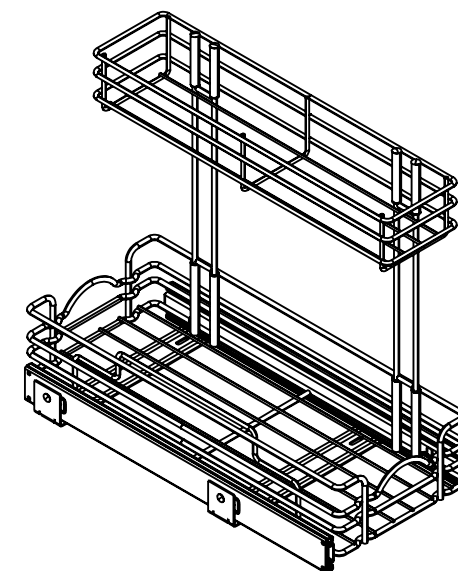
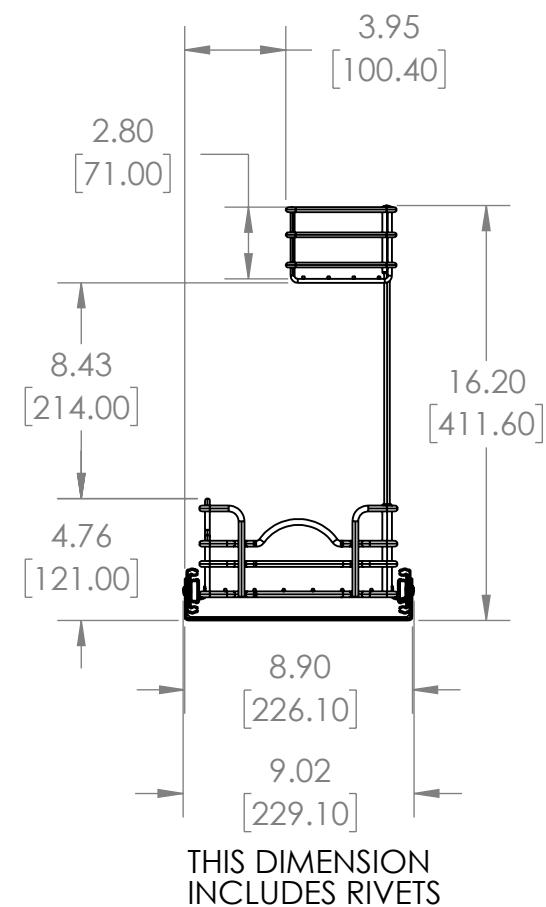
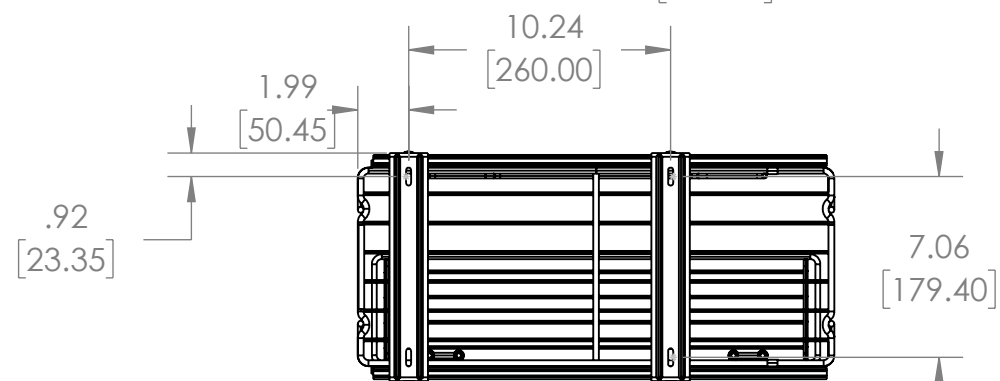
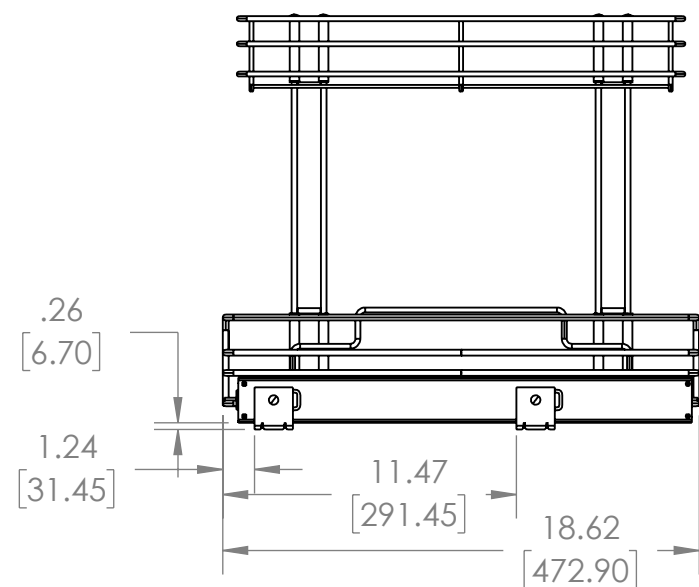
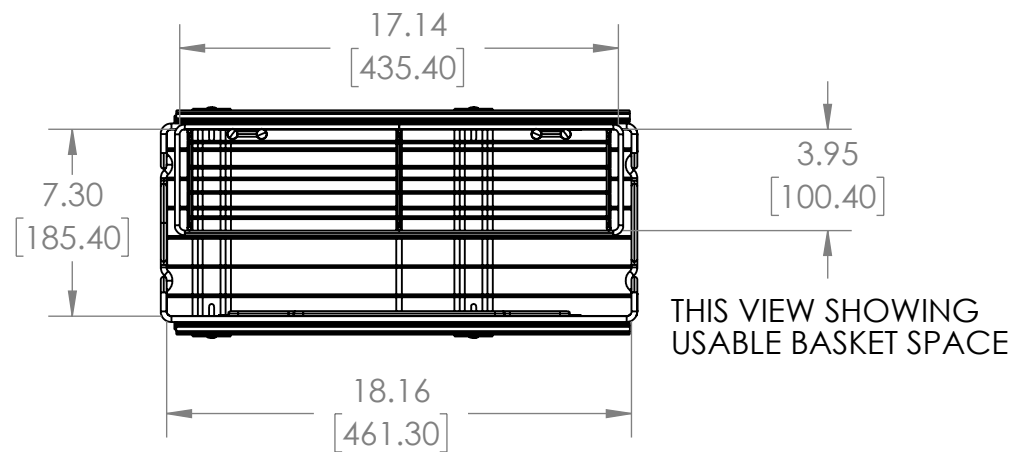

- NOTE:
1. SLIDES: 100LB FULL EXTENSION BALL BEARING SLIDES
 2. FINISH: POWDER COAT CHROME
 3. MATERIAL: COLD ROLLED STEEL



PROPRIETARY AND CONFIDENTIAL
 This drawing is the property of Rev-A-Shelf LLC (RAS) and is disclosed in confidence to the extent its subject matter is original to RAS. Any vendor receiving this drawing from RAS shall hold and use this drawing for the sole benefit of RAS and shall not disclose it to, or use or reproduce it for any third party, or perform any act adverse to the interest of RAS with respect to this drawing without the express written permission of RAS. Vendors shall not revise any physical, dimensional or performance characteristic unless authorized by Rev-A-Shelf Engineering.

UNCONTROLLED IF PRINTED

REV	DATE	BY	DESCRIPTION OF CHANGE

UNLESS OTHERWISE SPECIFIED:		Description:	
TOLERANCES = INCH/(MM) MAT. DEC. (WOOD) .XX +/--.03 [.8mm] (OTHER) .XX +/--.02 [.5mm] (ALL) .XXX +/--.005 [.13 mm] FRACTIONS +/-1/32 [.8 mm] ANGLES +/-1/2°		Bottom Mount Undersink Basket	
First Angle Projection		PART NO. 548WB-0919CR-1	
MATERIAL	FINISH	SIZE	DWG. NO.
DO NOT SCALE DRAWING	NAME	DATE	REV
DRAWN			
SCALE: 1:7.5		WEIGHT:	
		SHEET 1 OF 1	

4

3

2

1