

SM1202/2002

Series High Speed Servo Motor



PUSHCORP
Manual

**Do NOT overheat the servo motor.
Maintain a temperature below
176 °F (80 °C).**

**Do NOT start or stop the servo motor
instantaneously. Doing so will damage
the motor and power amplifier.**

**All *PushCorp* electrical cables are rated for high twist
and flex robotic applications with a minimum cable
bending radius specification of 125mm (5 in). Cable
damage resulting from failure to abide by this
specification will not be covered under warranty.**

Table of Contents

1.0 Limited Warranty	1
2.0 GENERAL OVERVIEW	3
3.0 INSTALLATION & OPERATION	4
3.1 Mounting to a PushCorp AFD Compliant Tool	4
3.1.1 Mounting to PushCorp AFD Compliant Tool.....	4
3.1.2 Mounting Directly to a Robot	5
3.2 Dust Collection	8
3.2.1 Dust Collection Hoses.....	10
3.3 Tool and Media Specification	11
3.3.1 SM Toolholder Specification	11
3.4 SM Collet Operation	12
3.4.1 SM Collet Assembly and Removal	12
3.5 SM1202/2002 Random Orbital Sanding Shafts	13
3.5.1 Sander Orbit Assembly	13
3.5.1 Sander Orbit Removal.....	13
3.5.3 Sander-Orbit Installation	14
3.6 Electrical Connections	16
3.6.1 AKD2G Servo Amplifier – Default Electrical Connections.....	17
3.6.2 Resolver Motor Timing Chart	18
3.7 Motor Cooling	19
3.8 Monitor Motor Temperature	20
4.0 TECHNICAL SPECIFICATIONS	21
4.1 SM1202	21
4.2 SM2002	22
5.0 PREVENTATIVE MAINTENANCE SCHEDULE	24

1.0 Limited Warranty

Duration:

One year from date of delivery to the original purchaser.

Who gives this warranty:

PushCorp
Telephone: (972) 840-0208

Corporate Address:
P.O. Box 181915
Dallas, Texas 75218

Shipping Address:
3001 W Kingsley Rd
Garland, Texas 75041

Who gives this warranty (purchaser):

The original purchaser (other than for purposes of resale) of the *PushCorp* product

What products are covered by this warranty:

Any *PushCorp* industrial equipment or accessory supplied or manufactured by the Warrantor.

What is covered under this warranty:

Defects in material and/or workmanship which occur within the duration of the warranty period

What is not covered in this warranty:

- a) IMPLIED WARRANTIES, INCLUDING THOSE OF MERCHANT-ABILITY AND FITNESS FOR A PARTICULAR PURPOSE ARE LIMITED TO ONE YEAR FROM THE DATE OF ORIGINAL PURCHASE. Some states do not allow limitations on how long an implied warranty lasts, so the above limitations may not apply to you.
- b) ANY INCIDENTAL, INDIRECT, OR CONSEQUENTIAL LOSS, DAMAGE or EXPENSE THAT MAY RESULT FROM ANY DEFECT, FAILURE, MALFUNCTION OF THE *PUSHCORP, INC.* PRODUCT. Some states do not allow the exclusion or limitation of incidental or consequential damages so the above limitation or exclusion may not apply to you.
- c) Any failure that results from an accident, purchaser's abuse, neglect, unauthorized repair or failure to operate the products in accordance with the instructions provided in the owner's manual(s) supplied with the product.

Responsibilities of the Warrantor under this warranty:

Repair or replace, at Warrantor's option, products or components which have failed within the duration of the warranty period.

Responsibilities of the purchaser under this warranty:

- a) Deliver or ship the *PushCorp* product or component to PushCorp Service Center, Dallas, TX. Freight and insurance costs, if any, must be borne by the purchaser.
- b) Use reasonable care in the operation and maintenance of the product as described in the owner's manual(s).

When warrantor will perform repair or replacement under this warranty:

Repair or replacement will be scheduled and serviced according to the normal workflow at the service center and depending on the availability of replacement parts. Purchasers requiring quicker repair may receive such with payment of a *PushCorp* predetermined expediting fee.

This Limited Warranty gives you specific legal rights and you may also have other rights which vary from state to state.

2.0 GENERAL OVERVIEW

This manual will cover the PushCorp SM1202 & SM2002. The SM1202 is capable of 2 horsepower and spinning up to 12000 RPM; the SM2002 is capable of 2 horsepower and spinning up to 20000 RPM. The motors come in two variations; a manual ER-20 collet, and a random orbital sander version. These versions utilize identical motor windings, and power amplifiers, differing only in a few physical dimensions and how they secure the media.

The Servo Manual (SM) model has a manually tightened collet. The “SM” models use the same motor winding and housing as the sander, differing only in orbit capabilities and media attachment. The manual Collet is a standard ER-20 series collet designed to clamp a ½ inch (12.7 mm) diameter Toolholder. The user may choose different sized collets in the ER-20 series, ranging from .031-.500 inch (1mm – 13mm).

The sander model consists of a universal motor housing and orbit shaft assembly. PushCorp can provide 9 different orbit shaft assemblies consisting of pad sizes of 3-3.5”, 5”, and 6”, and orbit of 3/8”, 3/16”, and 3/32”. The backup pad attachment is mounted via an orbit shaft with a 1/4-20 thread for the 3-3.5” pad, and 5/16-24 thread for the 5” and 6” pad. Each of these orbit shaft assemblies are compatible with the SM1202/2002 Sanders. PushCorp provides a dust shield for the SM1202/2002 Sander with dust collection capabilities aiding to provide a clean workcell; there is a respective dust shield for each size of back up pad.

All PushCorp motors use sealed bearings to ensure a long life. The bearings have additional contamination protection from a shaft seal. This seal eliminates the need for constant purge air.

During operation the motor generates considerable heat due to the high torque and compact size of the motor. Excessive operating temperatures will significantly reduce the life of the motor. Water Cooling is recommended for high duty cycle applications at higher toques to keep the unit within the internal temperature operating range. The motor should never be allowed to exceed a temperature of 176 °F (80 °C). Continuously operating the unit above 176 °F (80 °C) will cause the rotor to de-magnetize and the bearings to fail. High temperatures will also cause the gaskets that seal the cooling water channels to fail, possibly filling the motor with water. PushCorp has provided flow through water cooling on the motor to allow high duty cycles without overheating, and air cooling on the motor for lower duty cycles.

Simple reliable construction combined with high torque and precision speed controlled servo technology make the *PushCorp* SM1202/2002 Servo Motor line a rugged, state-of-the-art tool capable of providing flexible, cost-effective operations.

3.0 INSTALLATION & OPERATION

3.1 Mounting to a PushCorp AFD Compliant Tool

3.1.1 Mounting to PushCorp AFD Compliant Tool

The motors are designed to attach to the Carriage of any *PushCorp* AFD310/70 Force Device & AFD120/60 Force Device. There are two standard attachment options: parallel and perpendicular.

The parallel-axis configuration is shown in Figure 1, where the motor attaches to the AFD Carriage with a hoop bracket and foot bracket. The hoop bracket is positioned on the carriage and attached using the two (2) supplied M6x1x20mm socket head cap screws. The motor is then attached to the foot bracket, as shown, with two (2) M4x1x55mm socket head cap screws mounted at the front of the motor housing. The foot bracket is then mounted to the carriage via two (2) M6x1x20mm socket head cap screws. Finally, tighten the M5x.8x20 cap head screw at the top of the hoop bracket. The fasteners must be tightened to the torque specified in Section 4.0.

To attach the motor to an AFD in a perpendicular-axis configuration, position the motor and the required perpendicular mounting plate over the carriage as shown in Figure 2. Then mount the adapter plate to the carriage with four (4) M6x1x20 cap head screws. The motor can then be mounted to the adapter plate with four (4) M4x.7x55 cap head screws. Tighten the fasteners to the torque specified in Section 4.0.

CAUTION: Make sure that the M6x1 fasteners do not exceed a depth of 0.40" (10 mm) into the AFD Carriage Helicoils or damage will occur.

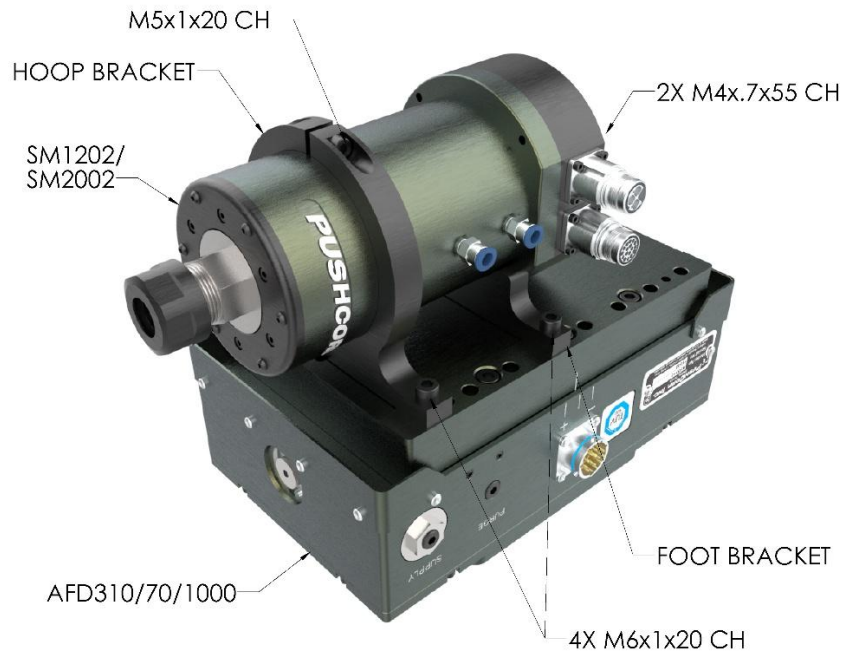

FIGURE 1: PARALLEL MOUNT

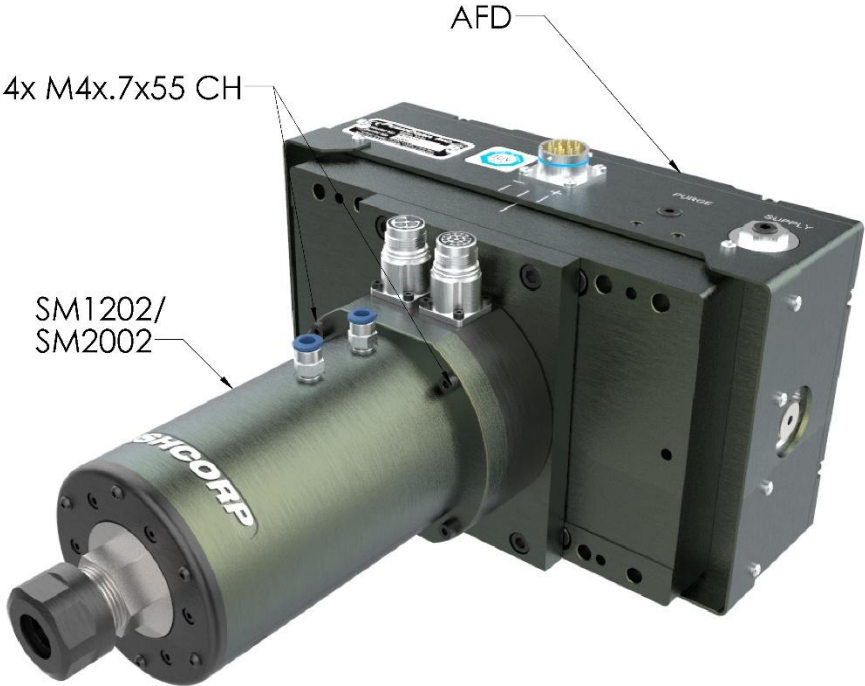

FIGURE 2: PERPENDICULAR MOUNT

3.1.2 Mounting Directly to a Robot

For some processes, compliance and force control are not required. The motor can be mounted directly to the robot. A few example applications utilizing this configuration are routing plastic and wood, as well as deflashing.

The motor can be attached to the robot mounting flange using a customer supplied mounting plate. For direct mounting, it is recommended that a breakaway clutch is installed. The breakaway clutch will help protect the motor in the event of a robot crash.

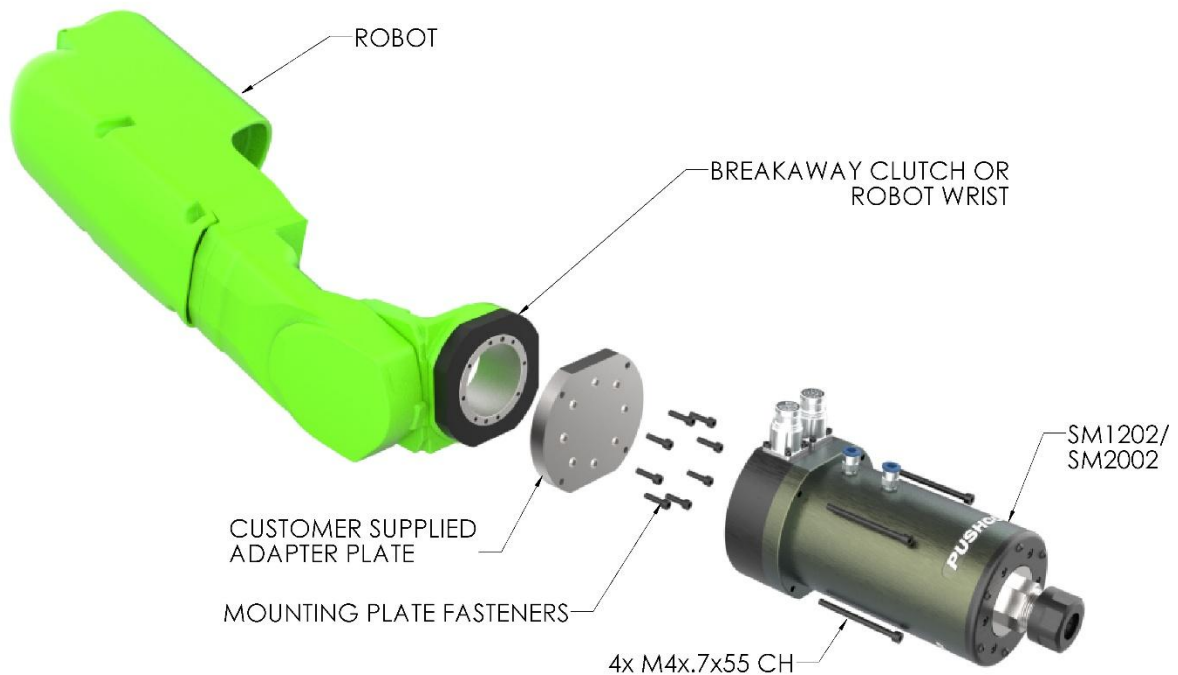
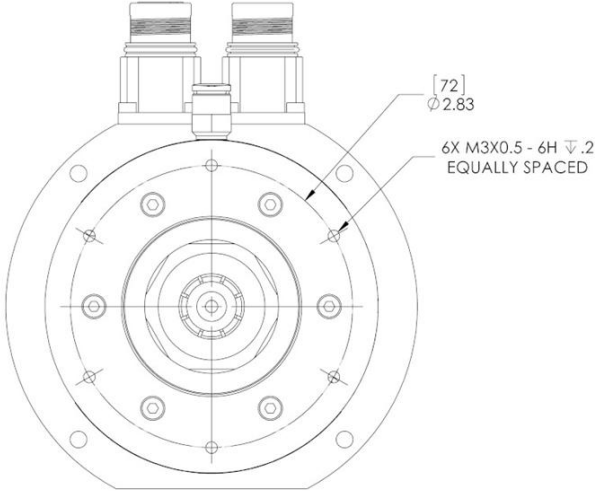

FIGURE 3: RIGID MOUNT

To mount the motor, first attach the customer supplied Mounting Plate to the Robot Mounting Flange or to the Breakaway Clutch, per the manufacturer’s specifications. Once the Mounting Plate is secured, place the motor against the Mounting Plate and install (4) four, M4x.7, Socket Head Cap Screws (See Figure 3). Tighten the fasteners to the torque specified in Section 4.0.

To assist with designing the adapter plate, refer to Figure 4.



Front Mounting Pattern

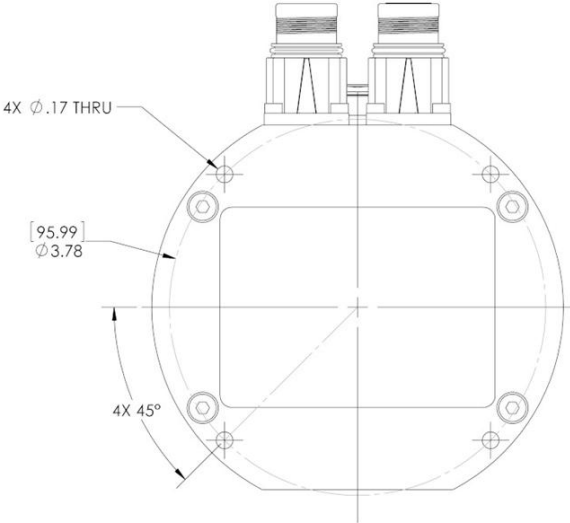

Rear Mounting Pattern

FIGURE 4: FRONT & REAR MOUNTING PATTERNS

3.2 Dust Collection

The SM1202/2002 has the option to be used with or without a dust collection system. To mount the dust shroud to the front of the SM1202/2002, begin by removing the six (6) button head cap screws with a hex key (See Figure 5).



FIGURE 5: DUST SHROUD INSTALLATION STEP 1

Next, slide the dust shroud over the lobes of the orbit shaft mounted on the SM1202/2002; if necessary, it is acceptable to remove the orbit shaft, mount the dust cover shroud, and then remount the orbit shaft. Secure the shroud to the front end cap of the SM1202, via the 6 tapped holes, with six (6) M3x0.5x8 cap heads.

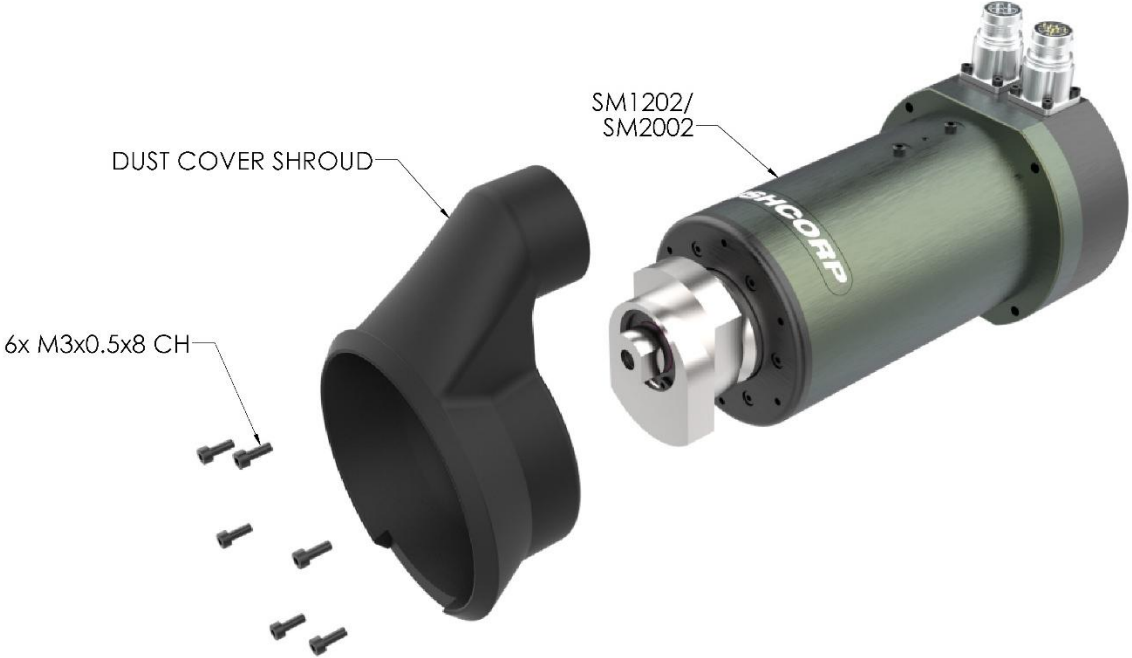

FIGURE 6: DUST SHROUD INSTALLATION STEP 2

The shroud is designed to mount to the spindle in 6 positions depending on the most efficient cable management scenario; the shroud can be clocked in increments of 60 degrees.



FIGURE 7: DUST SHROUD CLOCKING

Please refer to the following table to determine which PushCorp shroud is appropriate for your disk.

Table 1: Dust Collection Disk-Shroud P/N

Disk Size	PushCorp Shroud P/N
3.5"	ASM03514
5"	ASM03515
6"	ASM03516

3.2.1 Dust Collection Hoses

Once the SM1202/2002 is assembled for dust collection, it can be used with the following 3M tubing:

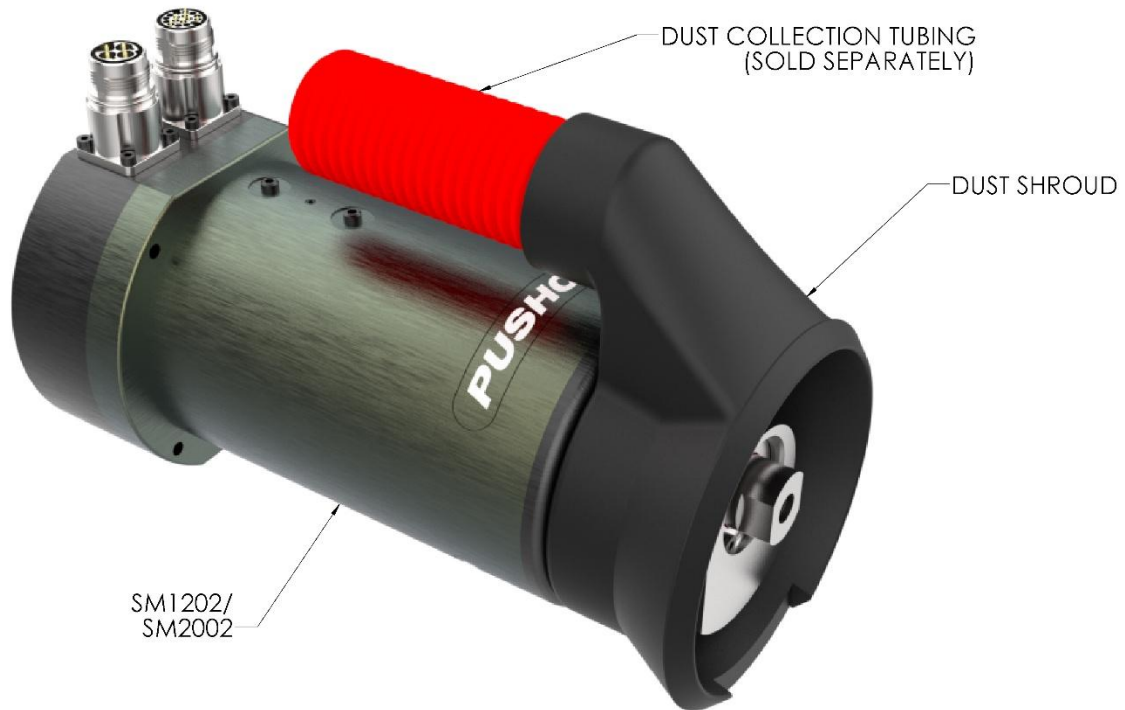

FIGURE 8: DUST COLLECTION SETUP

3.3 Tool and Media Specification

3.3.1 SM Toolholder Specification

The motors are designed to grasp a ½ inch (12.7mm) diameter steel shaft. Figure 9 shows the Toolholder dimensions required for the motor to operate properly. Notice that the end of the Toolholder can be tailored to any needed configuration to attach to various disk back-up pads, drill bits, router bits, grinding stones, etc. If desired, *PushCorp, Inc.* can fabricate custom Toolholders, at an additional cost, based on customer supplied drawings and specifications. To prevent interference between the Toolholder and the Collet, an 11° taper must be included in all Toolholder designs.

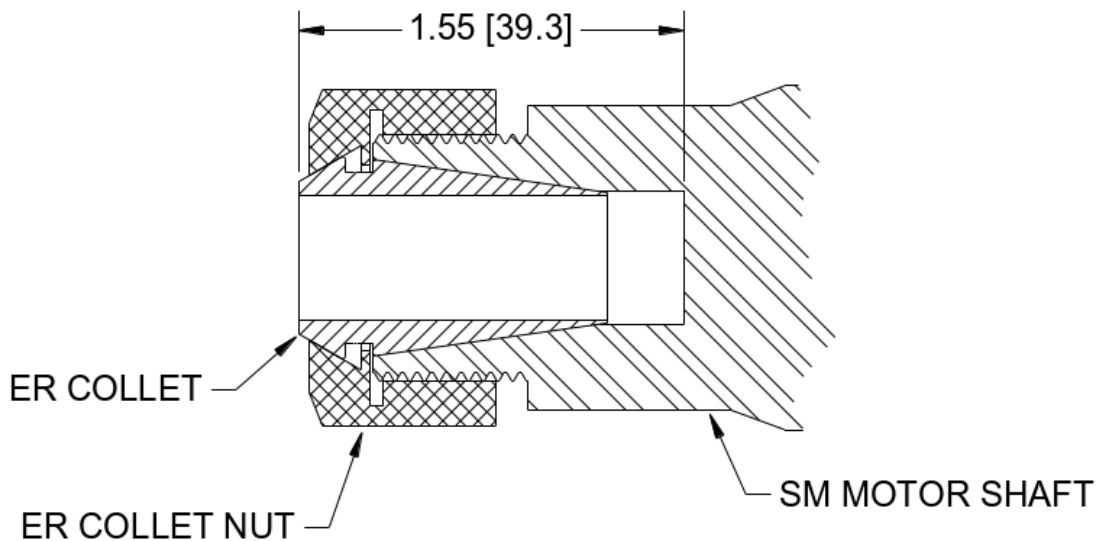

FIGURE 9: SM COLLET DRAWING

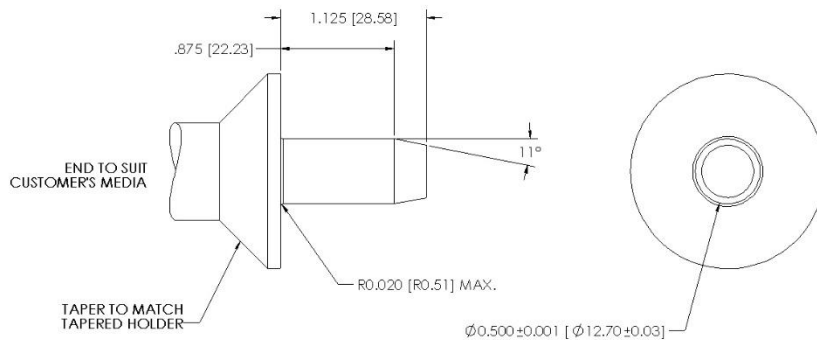

FIGURE 10: SM TOOLHOLDER DRAWING

3.4 SM Collet Operation

The Collet for the SM motor is tightened and loosened manually. The Motor Shaft must be held using the Motor Shaft Flats, while the Collet Nut is turned, see Figure 9. Turning the Collet Nut clockwise forces the Collet into the Motor Shaft causing it to clamp around the Toolholder. To loosen the Collet, rotate the Collet Nut counter-clockwise. If the Collet is to be removed, continue rotating the Collet Nut counter-clockwise and the Collet Nut and Collet will come off together. The Collet is an ER Series (DIN 6499 Form B) Size 20. The recommended tightening torque for the Collet Nut depends on the bore diameter of the Collet. For Collet bore diameters 0.276-0.512in (7.0-13.0mm) the recommended tightening torque is 60 lb-ft (80 N-m) and not to exceed 75 lb-ft (100 N-m). For Collet bore diameters 0.039-0.256in (1.0-6.5mm) the recommended tightening torque is 24 lb-ft (32 N-m) and not to exceed 30 lb-ft (40 N-m).

CAUTION: Tightening torques greater than recommended will permanently deform the collet cavity of the toolholder.

3.4.1 SM Collet Assembly and Removal

To assemble the Collet insert the Collet Groove into the Eccentric Ring of the Collet Nut at the mark on the bottom of the Collet Nut. Push the Collet in while rotating the Collet up, until it clicks in. See Figure 10.

Improper assembly or removal of the Collet can permanently destroy the concentricity of the Collet and may also result in a damaged Collet Nut.

NOTE: Only attach Collet Nuts with correctly assembled Collets, to the Motor Shaft! Never place the Collet into the Motor Shaft without first assembling the Collet into the Collet Nut.

NOTE: Never clamp oversized, or undersized, Toolholders! E.g. never use a Ø11-12mm Collet to clamp a Ø12.2mm Toolholder. Always use the corresponding Collet for the Toolholder being used.

Note: Insert the Toolholder the full length of the Collet for best results, if possible. However, never insert the Toolholder less than 2/3 of the Collet bore length. Improper tool insertion can permanently deform the Collet and will result in excessive run-out.

3.5 SM1202/2002 Random Orbital Sanding Shafts

The SM1202/2002 Sander is composed of a universal base that can be used with various orbits and pad sizes, and an orbit assembly. The pad can be attached and removed by using the threaded bearing shaft; the 3-3.5" pad is designed for a 1/4-20 thread, and the 5" and 6" pad are designed for 5/16-24 thread. The sander also has an optional dust removal system with a respective dust cover designed for each disk size. The dust cover is equipped with a tubing port to assist keep a clean workcell. The fitting kit for each variation of SM1202/2002 Sander includes collection components.

The dust cover is mounted via six (6) M3 tapped holes on the circular front cover as seen in Figure 4. When not being utilized, the tapped holes should have place holder button head fasteners; this is meant to protect the internal components. The tapped holes are capable of being used for the dust cover shroud and other external hardware.

3.5.1 Sander Orbit Assembly

The SM1202/2002 uses the same motor housing across all orbits and pad sizes. This allows the user to swap orbit assemblies to meet their application needs. The table below lists the corresponding PushCorp P/N to the particular disk size and orbit diameter:

Orbit Diameter	3.5" Disk	5" Disk	6" Disk
3/8"	ASM03520	ASM03523	ASM03526
3/16"	ASM03521	ASM03524	ASM03527
3/32"	ASM03522	ASM03525	ASM03528

3.5.1 Sander Orbit Removal

The SM1202/2002 Sander uses a universal motor housing that is capable of being used across all orbits and pad sizes. To remove the orbit assembly, begin by removing the snap ring shown in Figure . Next, pull the bearing, four (4) disc springs, and threaded bearing shaft out from the counter bore using the T-6 Lock Ring Wrench (P/N: PAR05009). There are two different threads available on the Lock Ring Wrench tool; the 1/4-20 thread is used to remove the orbit shaft used with the 3IN pads, and the 5/16-24 thread is used to remove the orbit shaft used with the 5IN & 6IN pads.

Thread the lock-wrench onto the bearing shaft using the appropriate thread, position the cylinder on the lock-ring wrench until it is bottomed out closest to the motor housing, and then accelerate the cylinder away from the motor to provide an axial force. Repeat this process as necessary until the bearing is removed from the orbit shaft.

Finally, use a hex key to remove the M5 fastener at the bottom of the orbit shaft.

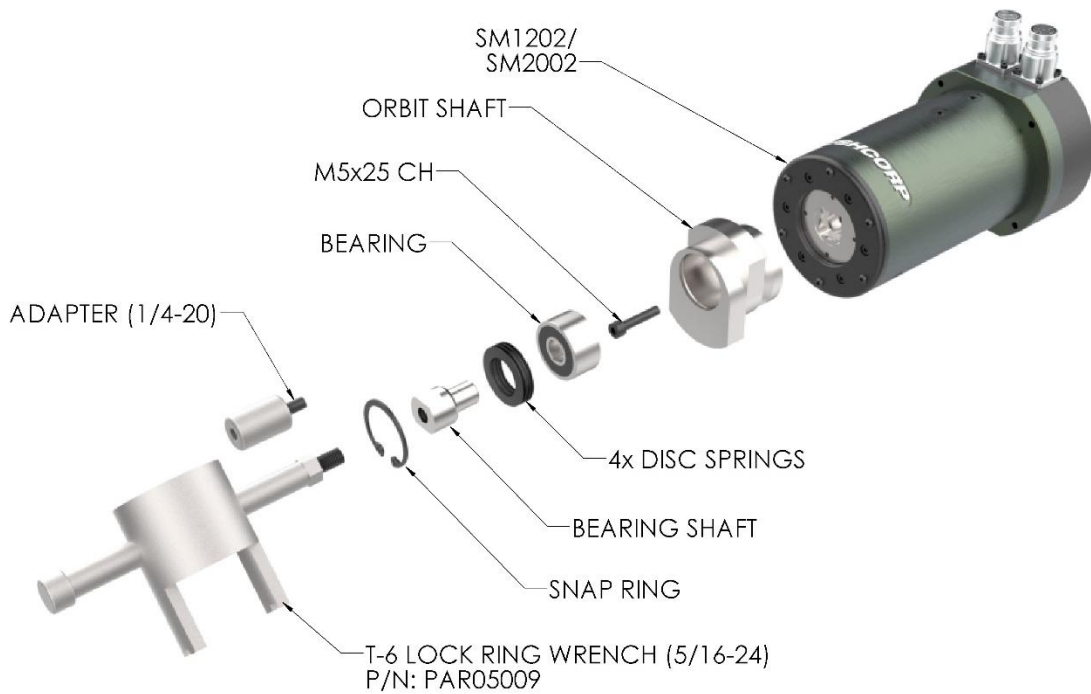

FIGURE 11: SANDER ORBIT COMPONENT STACK UP

3.5.3 Sander-Orbit Installation

To install a new orbit shaft begin by applying Loctite 266 to the M5x.8x25 CH to prevent the fastener from backing out and tighten to a torque of 90 in-lbs.



FIGURE 12: ORBIT ASM ASSMEBLY STEP 1

Then press the bearing/bearing shaft ASM into the counterbore located on the orbit shaft as shown in Figure 14.



FIGURE 13: ORBIT ASM ASSEMBLY STEP 2

The next step is to install the disc springs followed by the snap ring. Align the disc springs in the orientation seen in Figure 14, and then use a pair of snap ring pliers to position the snap ring within the internal diameter of the counterbore. Finally, use an arbor press and PAR05235 to compress the disc springs and position the snap ring into the snap ring groove.

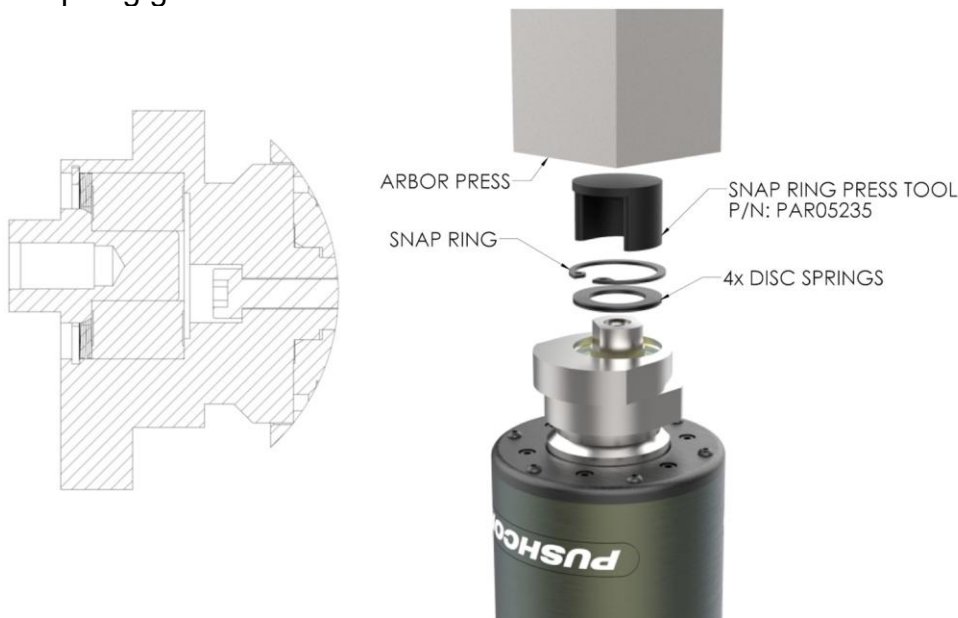

FIGURE 14: ORBIT ASM ASSEMBLY STEP 3

The opening in PAR05235 allows you to maintain the downward force while accessing the snap ring with pliers. For any questions regarding this procedure, you can reach out to techsupport@pushcorp.com

3.6 Electrical Connections

The SM1202/2002 servo motor has two electrical connections, the Motor Power and Motor Feedback (See Figure 16).

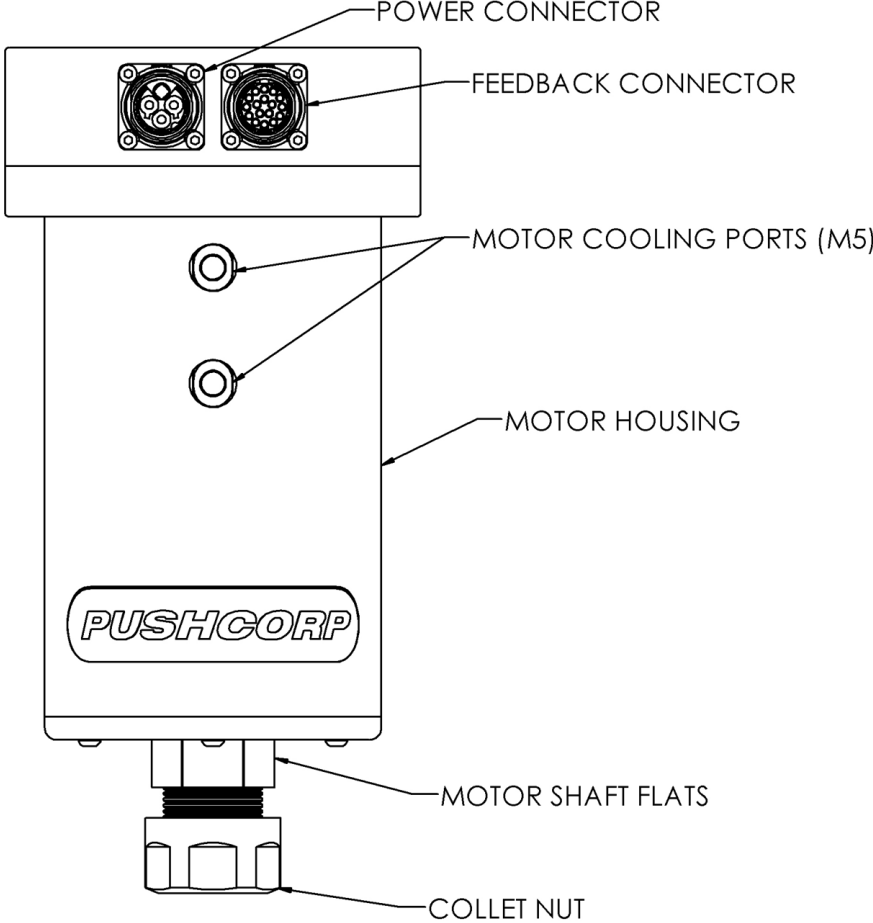

FIGURE 15: SM1202/2002 EXTERNAL FEATURES

3.6.1 AKD2G Servo Amplifier – Default Electrical Connections

This amplifier is already properly configured for a PushCorp spindle. No further configuration is required if the below settings will work for your application.

Analog Interface

Connector	Pin	Function
X21	A1	Analog-In 1+ : +/-10VDC Command Velocity
X21	A2	Analog-In 1- : +/-10VDC Command Velocity
X21	B1	Analog-Out 1 : 0 - 10VDC Velocity Monitor
X21	B2	AGND : Analog GND
CASE		Shield

Digital Interface

Connector	Pin	Function
X21	A3	Digital-In 1 : Fault Reset Input
X21	A4	Digital-In 2 : Run Input
X21	A5	Enable : Enable Drive Input
X21	B3	+24VDC : Digital Output Supply
X21	B4	DGND : Digital I/O Common
X21	B5	BTB/RTO : Ready To Operation (Dry Contact)
X21	B6	BTB/RTO : Ready To Operation (Dry Contact)
X21	B7	Digital-Out 1 : Motor Overload Warning
X21	A11	STO-A-A1 : Safety Torque Off A Input
X21	B11	STO-B-A1 : Safety Torque Off B Input

For more information an instruction manual is available at:

[AKD2G-instruction-manual.pdf](#)

For all other questions please contact:

PushCorp Tech Support: 1.972.840.0208, 8am – 5pm Central Time

Kollmorgen Tech Support: 1.540.633.3545, 8am – 5pm Eastern Time

3.6.2 Resolver Motor Timing Chart

S724 – Hall Motors
Error Reset and Servo ON/OFF

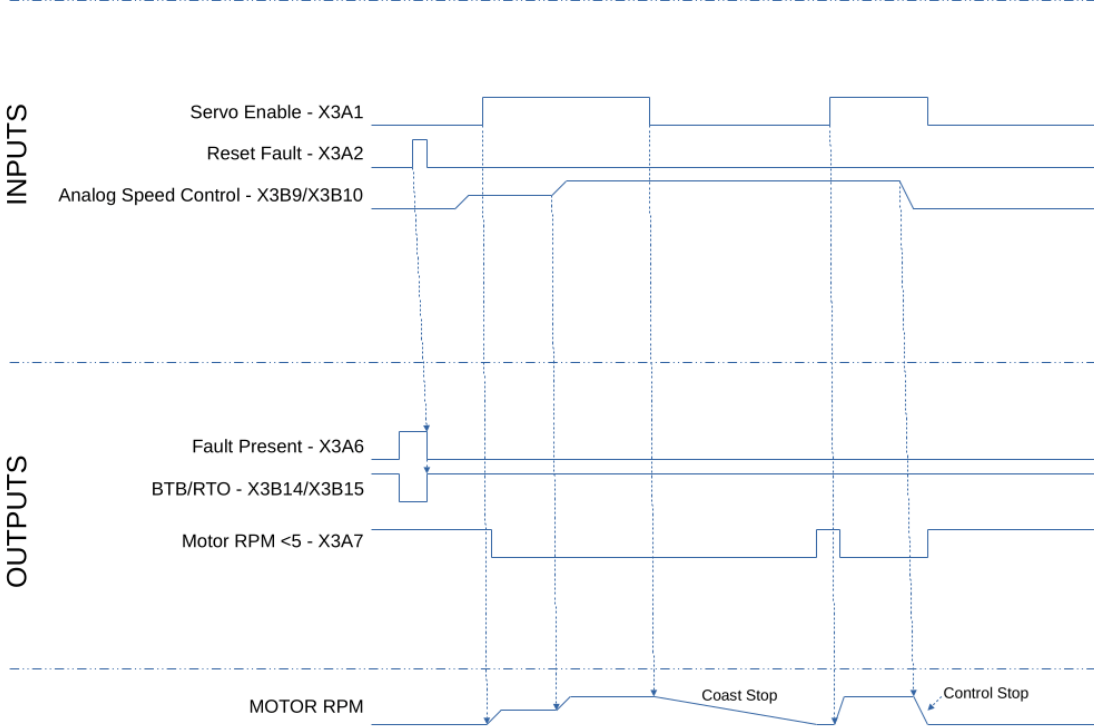

3.7 Motor Cooling

The SM1202/2002 is designed to operate below a temperature of 176 °F (80 °C). The optimal motor temperature range is 122 – 140 °F (50 – 60 °C). The motor contains cooling channels in the Motor Housing surrounding the motor stator. These channels allow liquid cooling to efficiently remove heat. The coolant enters and exits the Motor Housing through two Motor Cooling Ports. Either of these motor cooling ports can be used as an input, the other would then become an output.

A closed-loop water cooling system must be used and requires a separate cooling unit per spindle that circulates water through the Motor Housing to remove the heat. Typical cooling units are comprised of a pump, liquid to air heat exchange, and a fan. These units are commercially available from several manufacturers (e.g. Miller Coolmate 3, www.millerwelds.com). The cooling unit should be sized based on the motor power output of the motor being used with an overall motor efficiency of 90% and the motor load conditions. See section 4.0 of this manual for motor output ratings for the motor being used. In the case of a closed-loop water cooling system, all of the coolant is recirculated in the system, and no continuous supply of discharge is required. Our standard offering is the Miller Coolmate 3, PCI PN PAR03962. In this case the return line is the bottom connection; it is recommended that a flow sensor is installed inline with this port and wired back as part of the control circuit. PushCorp recommends the IFM flow sensor (PN SBG12IF0FRKG). This will ensure the coolant is circulating completely through the motor and back to the cooler. Domestically, PushCorp provides Miller's pre-mixed glycol base aluminum protecting coolant (Miller PN 043-809 – PCI PN PAR04028). Any coolant which matches the parameters of this coolant may be used.

NOTE: Connecting two motors to a single Coolmate could yield inadequate cooling and reduce the life of the servo unit. The life of the motor is directly related to the operational temperature, so proper cooling is critical.

Again, it is recommended to constantly monitor the motor temperature during operation to ensure that it does not overheat. In addition, PushCorp recommends that one Miller Coolmate 3 (or equivalent) should be used per motor.

3.8 Monitor Motor Temperature

As previously stated, the motor is designed to operate below a temperature of 176 °F (80 °C) and within an optimal range of 122-140 °F (50-60 °C). In many situations it is desirable to monitor the internal motor temperature to ensure that the maximum temperature rating is not exceeded, and that the optimal temperature range is maintained. To facilitate this, the motor has a thermistor that is embedded in the motor windings. The thermistor connection is provided on the Motor Feedback Connector. The thermistor temperature signal is a logarithmic function of the output resistance.

The motor also contains a thermal cutoff switch. If the temperature exceeds 212 °F (100 °C) the motor will stop running until it has cooled off. **This feature should not be used to control the motor temperature.** The thermal cutoff is designed to operate only when all other precautions have failed.

The following equation can be used to calculate the motor temperature based on the measured thermistor resistance:

$$T = \frac{14.362 + \ln\left(\frac{R}{20}\right)}{4282} - 273.15$$

T = temperature (°C)

R = resistance of thermistor (kΩ)

ln(x) = natural logarithmic function (Base e)

Given Values:

R₀ = 20kΩ – The R₂₅ value from the thermistor data sheet

β = 4282 (B Value from the thermistor data sheet)

T₀ = 298.15 K (reference temperature in Kelvins from the thermistor data sheet)

NOTE: Thermistor type – Semitec 203GT-2

4.0 TECHNICAL SPECIFICATIONS

4.1 SM1202

Category	Specification
Power	2.0 hp (1.5 kW)
Continuous Stall Torque	Air Cooled: 0.74 lb-ft (1.0 N-m) Liquid Cooled: 1.33 lb-ft (1.8 N-m)
Speed Range	0-12,000 RPM
Speed Regulation	5% (Reversible)
Weight	SM1202: 10.5 lb (4.8 kg) SM1202 Sander: 9 lbs (4.1 kg)
Operating Temperature	Optimal: 122-140F (50-60C) Max: 176F (80C)
Max Coolant Pressure	60 psi (4.1 bar)

POWER

Supply Voltage	Max Speed
480 VAC, 3-Phase	12,000 RPM

COLLET

Parameter	Value
Holding Torque	10 lb-ft (20.3 N-m) minimum
Toolholder	ER Ø0.5in (12.7 mm) standard

CABLE AND TUBING

Cable Diameter	1193 – 9.1 mm (.36 in) 811, A8, & A4 – 7.6 mm (.30 in) 4684 & X8- 6.6 mm (.26 in) 4936 – 7.7 mm (.30 in)
Cable Bending Radii	1193, 811, A8, & A4 flexing ~ 7.5x cable ø fixed installation ~ 4x cable ø 4936, 4684, & X8 flexing ~ 10x cable ø fixed installation ~ 5x cable ø
Max Temperature	Flexing: - 4° to 176 °F (20 °C to +80 °C) fixed: - 40° to 176 °F (40 °C to +80 °C)
Certifications	RoHS
Airline OD	6mm
Airline ID	4mm

4.2 SM2002

Category	Specification
Power	2.0 hp (1.5 kW)
Continuous Stall Torque	Air Cooled: 0.74 lb-ft (1.0 N-m) Liquid Cooled: 1.33 lb-ft (1.8 N-m)
Speed Range	0-12,000 RPM
Speed Regulation	5% (Reversible)
Weight	SM2002: 9 lb (4.1 kg) SM2002 Sander: 9 lbs (4.1 kg)
Operating Temperature	Optimal: 122-140F (50-60C) Max: 176F (80C)
Max Coolant Pressure	60 psi (4.1 bar)

POWER

Supply Voltage	Max Speed
208 VAC, 3-Phase	20,000 RPM
110 VAC, 1-Phase	10,000 RPM

COLLET

Parameter	Value
Holding Torque	10 lb-ft (20.3 N-m) minimum
Toolholder	ER Ø0.5in (12.7 mm) standard

CABLE AND TUBING

Cable Diameter	1193 – 9.1 mm (.36 in) 811, A8, & A4 – 7.6 mm (.30 in) 4684 & X8- 6.6 mm (.26 in) 4936 – 7.7 mm (.30 in)
Cable Bending Radii	1193, 811, A8, & A4 flexing ~ 7.5x cable ø fixed installation ~ 4x cable ø 4936, 4684, & X8 flexing ~ 10x cable ø fixed installation ~ 5x cable ø
Max Temperature	Flexing: - 4° to 176 °F (20 °C to +80 °C) fixed: - 40° to 176 °F (40 °C to +80 °C)
Certifications	RoHS
Airline OD	6mm
Airline ID	4mm

TORQUE SPECIFICATIONS:

Fastener Tightening Torque Specs					
Fastener Size	Torque			Minimum Depth	
	in.-lbs.	ft.-lbs.	N·m	in.	mm
M4 x .7	50	4.2	5.6	0.17	4.3
M5 x .8	85	7.1	9.6	0.21	5.3
M6 x 1	140	11.7	15.8	0.25	6.3
M8 x 1.25	348	29.0	39.3	0.33	8.4
M10 x 1.5	600	50.0	67.8	0.41	10.5

5.0 PREVENTATIVE MAINTENANCE SCHEDULE

It is highly recommended to adhere to the preventative maintenance schedule in order help extend the longevity of the specified PushCorp, Inc. equipment. Failing to do so could cause a loss in functionality as well as a decrease in product life.

PUSHCORP SPINDLES			
Maintenance	Weekly	Monthly	3 Months
Wipe shaft (inside and out) and tool holders with a lint free cloth until clean and no debris remains. Use denatured alcohol if there is any grime or coatings.	X		
Remove debris from spindle/spindle housing.	X		
Check that the connectors are not bent/damaged.	X		
Check for flow in the motor cooling ports.		X	

Agency/Organization: _____

Date Completed: _____