

	MIN	MAX
A	17.50	19.58
B	21.75	24.00

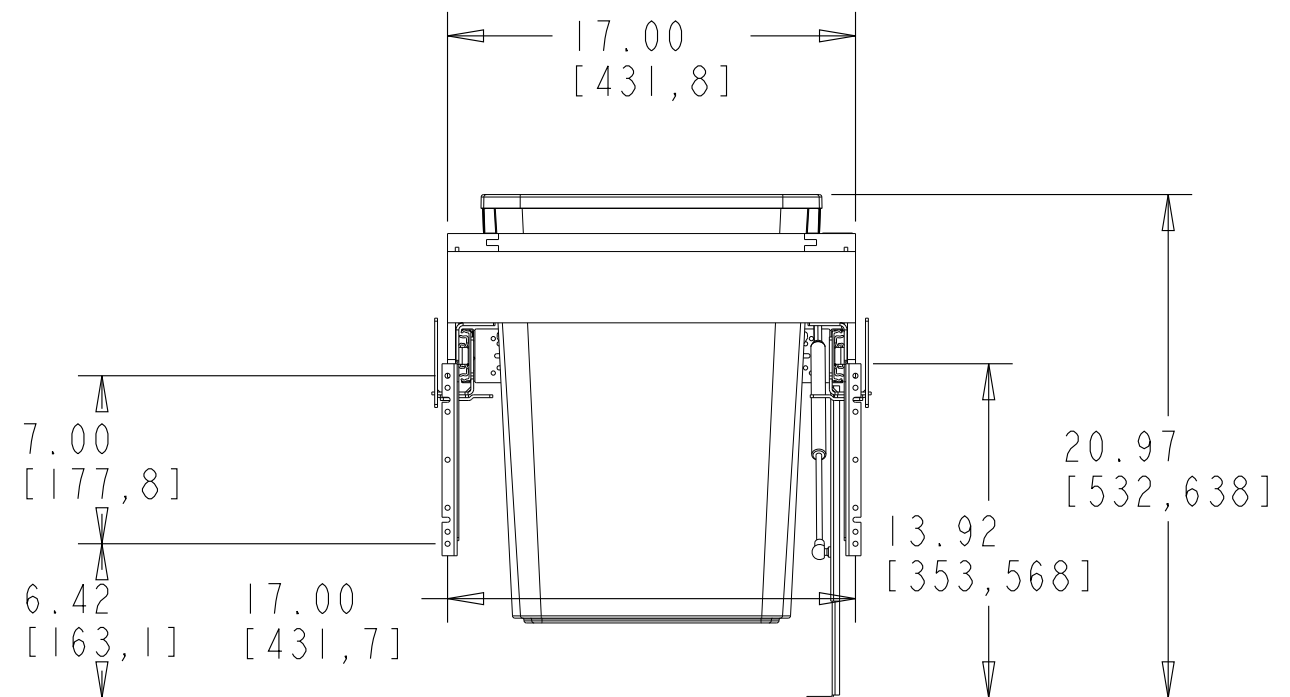
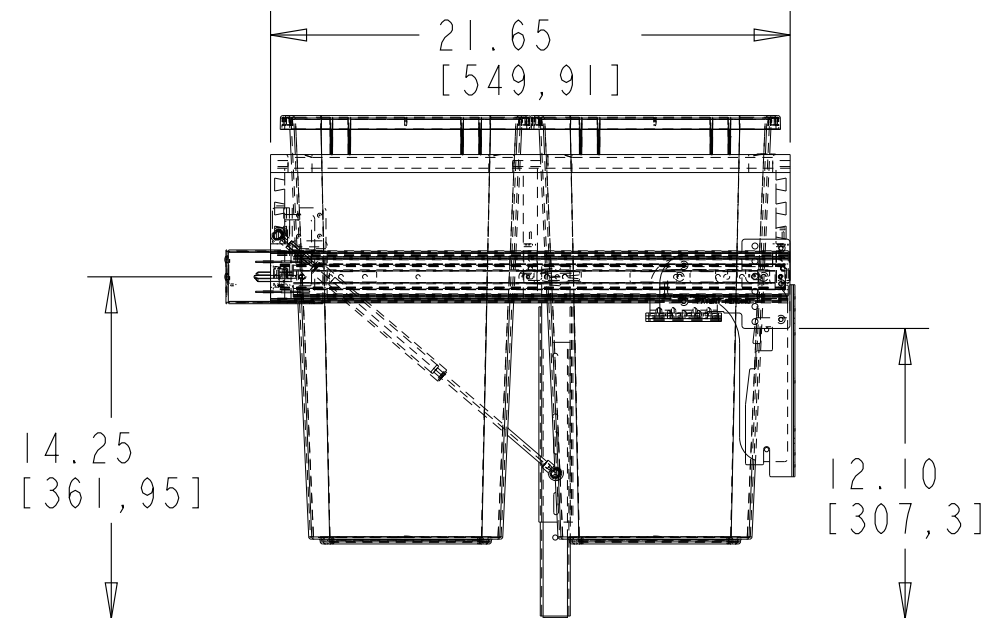
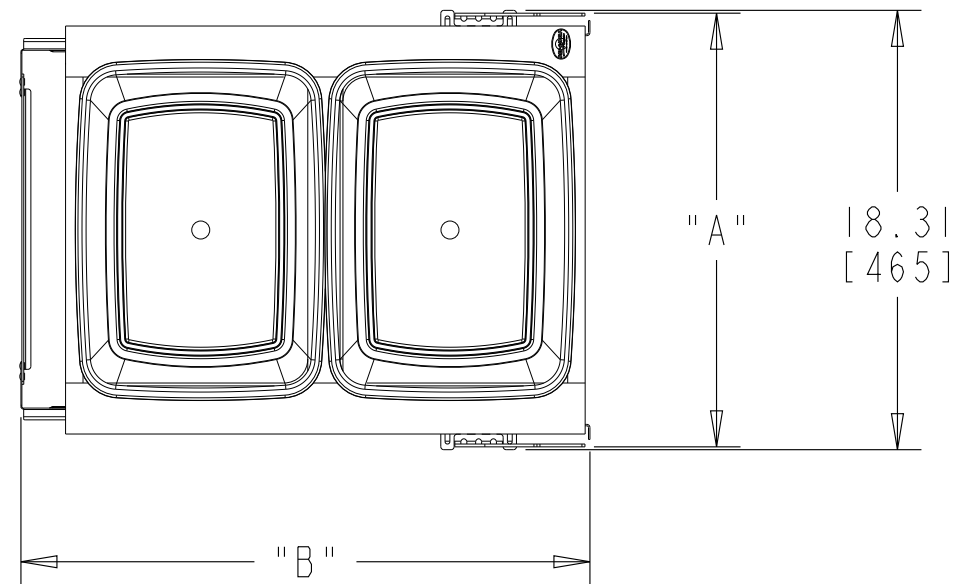

CUSTOMER DRAWING

This drawing is the property of Rev-A-Shelf (RAS) and is disclosed in confidence to the extent its subject matter is original to RAS. Any vendor receiving this drawing from RAS shall hold and use this drawing for the sole benefit of RAS and shall not disclose it to, or use or reproduce it for any third party, or perform any act adverse to the interest of RAS with respect to this drawing without the express written permission of RAS. Vendors shall not revise any physical, dimensional or performance characteristic unless authorized by Rev-A-Shelf Engineering.

REV.	DATE	BY	DESCRIPTION OF CHANGE

INCH [MM]	AMERICAN PROJECTION	DRAWN	BY	DATE	REV-A-SHELF, INC.	
			PFC	9/30/10	SIZE	REV-A-MOTION TOP MOUNT DOUBLE 35 QT
TOLERANCES		ANGLES ±1/2°	MATERIAL	DRAWING NO.	SCALE	
MAT. (WOOD)	DEC. .XX ±.03 [8mm]		FINISH	4WCTM-RM-2135DM-2.CUSTOMER	0.125	
(OTHER) .XX ±.02 [5mm]			PART NO.	SHEET OF		
(ALL) .XXX ±.005 [13 mm]			4WCTM-RM-2135DM-2	1 2		
FRACTIONS ±1/32 [8 mm]						

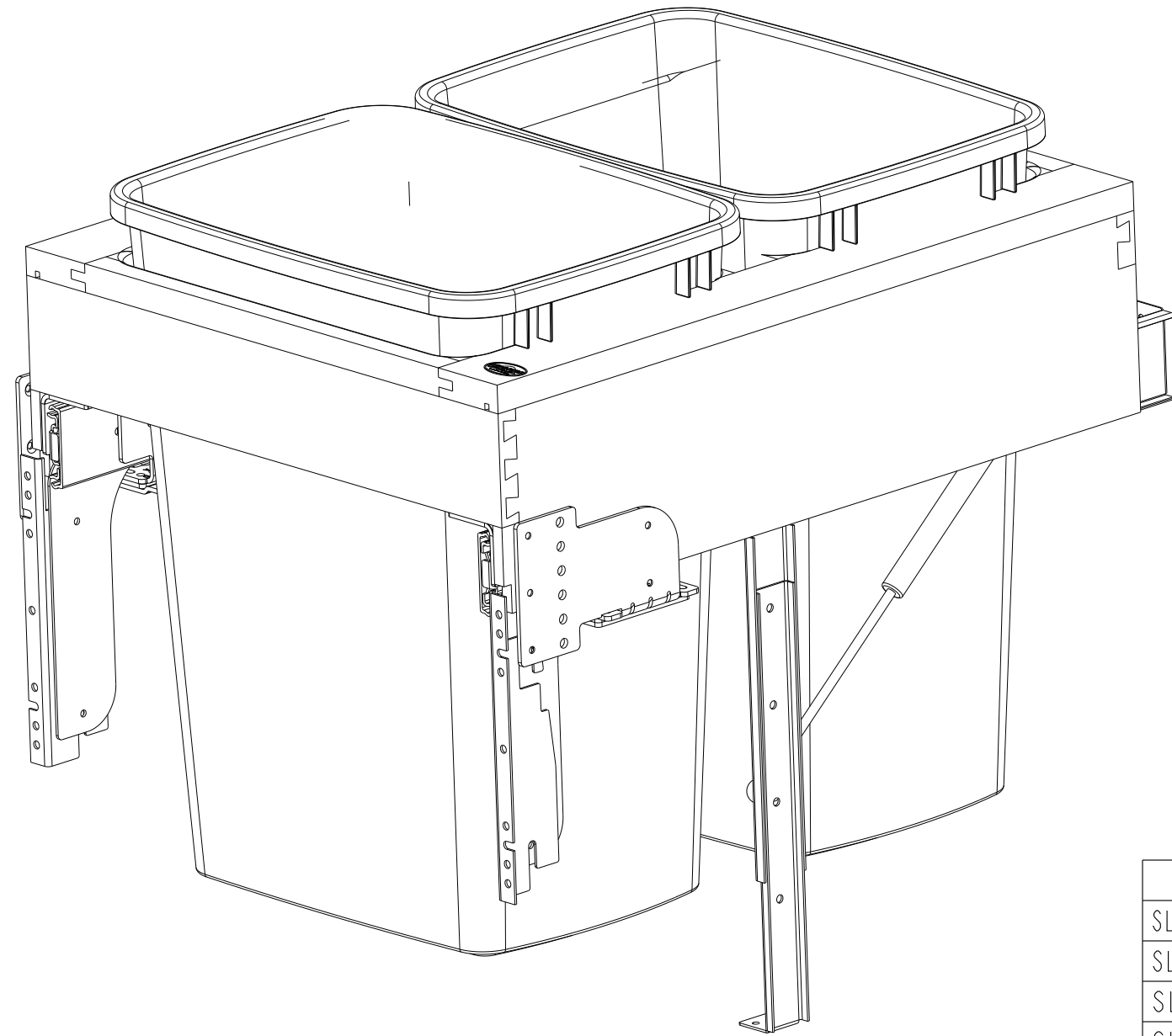

PART DIMENSIONS		
	MIN	MAX
WIDTH	18.31	
DEPTH	21.75	24.00
HEIGHT	20.97	
CONTAINER CAPACITY	35	
CONTAINER UOM	QT	

MIN CABINET OPENING				
	FACE FRAME	FRAMELESS	INSET FACE FRAME	INSET FRAMELESS
WIDTH	17.50	18.31	17.50	18.31
DEPTH	21.75	21.75	22.50	22.50
HEIGHT	21.25	21.25	21.25	21.25

SLIDE SPECIFICATIONS				
SLIDE MANUFACTURER				
SLIDE PART NUMBER	FX80215	RELEASE PART NUMBER		
SLIDE TYPE	BALL BEARING	SLIDE EXTENSION	1.50" O.T.	MAX WEIGHT RATING
SLIDE CLOSING	SOFT	SLIDE LENGTH	21.50" [550,0]	
SLIDE MOUNTING	SIDE	SLIDE FINISH	ZINC	150LB

CUSTOMER DRAWING

This drawing is the property of Rev-A-Shelf (RAS) and is disclosed in confidence to the extent its subject matter is original to RAS. Any vendor receiving this drawing from RAS shall hold and use this drawing for the sole benefit of RAS and shall not disclose it to, or use or reproduce it for any third party, or perform any act adverse to the interest of RAS with respect to this drawing without the express written permission of RAS. Vendors shall not revise any physical, dimensional or performance characteristic unless authorized by Rev-A-Shelf Engineering.

REV.	DATE	BY	DESCRIPTION OF CHANGE

INCH [MM]	AMERICAN PROJECTION	DRAWN	BY	DATE	REV-A-SHELF, INC.
			PFC	9/30/10	
			MATERIAL	DRAWING NO.	SCALE
			FINISH	4WCTM-RM-2135DM-2-CUSTOMER	0.250
				PART NO.	SHEET OF
				4WCTM-RM-2135DM-2	2 OF 2

TOLERANCES
 MAT. DEC.
 (WOOD) .XX ±.03 [.8mm]
 (OTHER) .XX ±.02 [.5mm]
 (ALL) .XXX ±.005 [.13 mm]
 FRACTIONS ±1/32 [.8 mm]

ANGLES ±1/2°