

CUSTOMER DRAWING

This drawing is the property of Rev-A-Shelf (RAS) and is disclosed in confidence to the extent its subject matter is original to RAS. Any vendor receiving this drawing from RAS shall hold and use this drawing for the sole benefit of RAS and shall not disclose it to, or use or reproduce it for any third party, or perform any act adverse to the interest of RAS with respect to this drawing without the express written permission of RAS. Vendors shall not revise any physical, dimensional or performance characteristic unless authorized by Rev-A-Shelf Engineering.

REV.	DATE	BY	DESCRIPTION OF CHANGE
B	7/6/20	LLS	ECN20-050
A	4/8/20	BKT	ECN20-025

INCH [MM]	AMERICAN PROJECTION 	BY	DATE	REV-A-SHELF, INC.	
		PFC	6/25/19	SIZE	8" BASE CABINET FH, KB
TOLERANCES		MATERIAL	DRAWING NO.	SCALE	
MAT.	DEC.		448KB-BCSC-8C		0.150
(WOOD)	.XX ±.03 [.8mm]	FINISH	PART NO.	SHEET OF	
(OTHER)	.XX ±.02 [.5mm]		448KB-BCSC-8C		1 2
(ALL)	.XXX ±.005 [.13 mm]	ANGLES ±1/2°			
FRACTIONS	±1/32 [.8 mm]				

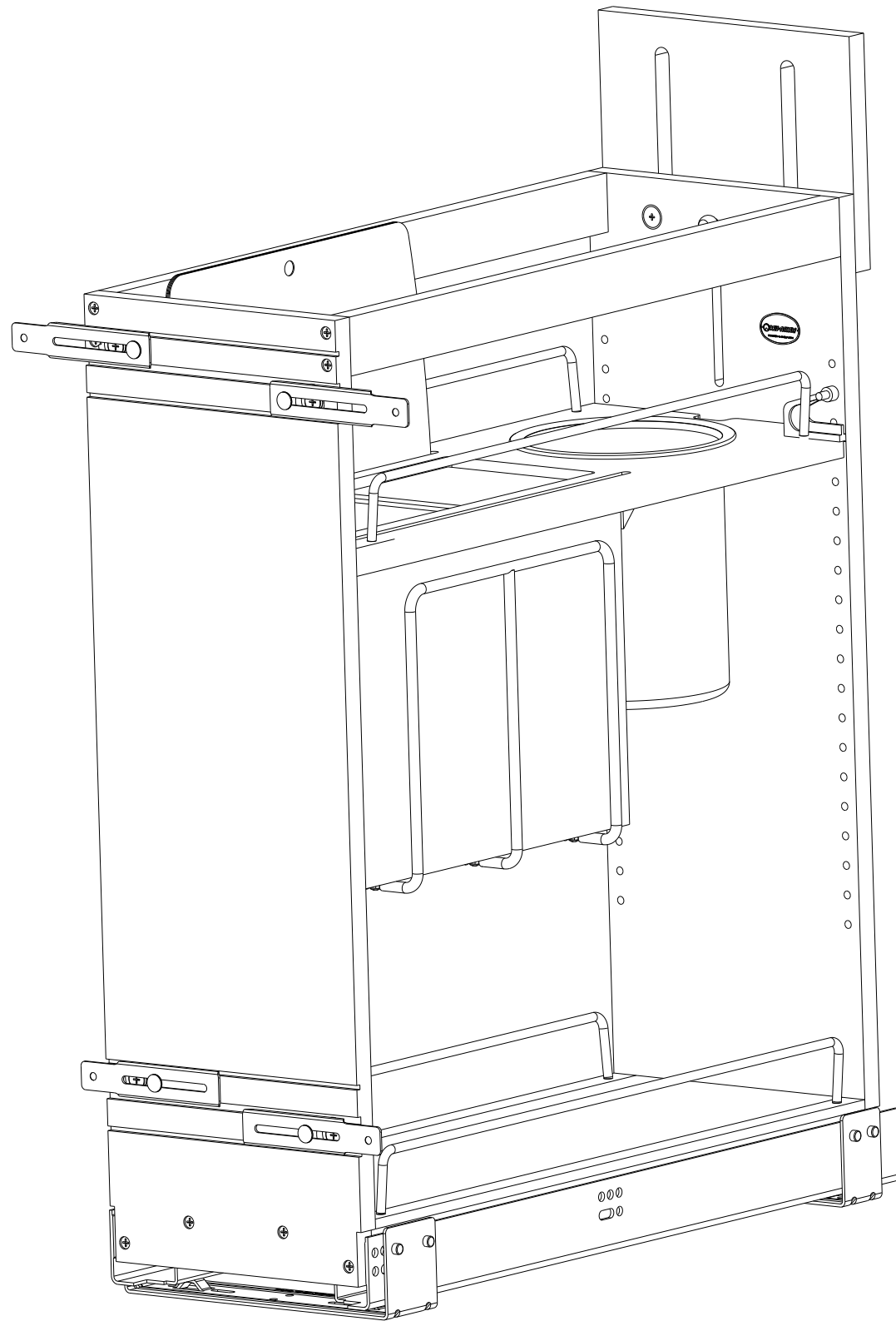

PART DIMENSIONS

	MIN	MAX
WIDTH	8.71 [221.3]	
DEPTH	21.65 [550.0]	
HEIGHT	25.50 [647.8]	29.50 [749.3]
CONTAINER CAPACITY	2.0	
CONTAINER UOM	QUART	

MIN CABINET OPENING

	FACE FRAME	FRAMELESS	INSET FACE FRAME	INSET FRAMELESS
WIDTH	8.50 [215.9]	9.00 [228.6]	8.50 [215.9]	9.00 [228.6]
DEPTH	21.65 [550.0]	21.65 [550.0]	22.40 [569.0]	22.40 [569.0]
HEIGHT	25.75 [654.1]	25.75 [654.1]	25.75 [654.1]	25.75 [654.1]

SLIDE SPECIFICATIONS

SLIDE MANUFACTURER	BLUM			
SLIDE PART NUMBER	569H5330B	RELEASE PART NUMBER	T51-1801	
SLIDE TYPE	UNDERMOUNT	SLIDE EXTENSION	FULL	MAX WEIGHT RATING
SLIDE CLOSING	SELF/SOFT	SLIDE LENGTH	21.65 [550.0]	
SLIDE MOUNTING	BOTTOM	SLIDE FINISH	ZINC	135 LB

CUSTOMER DRAWING

This drawing is the property of Rev-A-Shelf (RAS) and is disclosed in confidence to the extent its subject matter is original to RAS. Any vendor receiving this drawing from RAS shall hold and use this drawing for the sole benefit of RAS and shall not disclose it to, or use or reproduce it for any third party, or perform any act adverse to the interest of RAS with respect to this drawing without the express written permission of RAS. Vendors shall not revise any physical, dimensional or performance characteristic unless authorized by Rev-A-Shelf Engineering.

REV.	DATE	BY	DESCRIPTION OF CHANGE
B	7/6/20	LLS	ECN20-050
A	4/8/20	BKT	ECN20-025

INCH [MM]	AMERICAN PROJECTION	DRAWN	BY	DATE	REV-A-SHELF, INC.
			PFC	6/25/19	
			MATERIAL	DRAWING NO.	SCALE
			FINISH	448KB-BCSC-8C	0.250
				PART NO.	SHEET OF
				448KB-BCSC-8C	2 OF 2

TOLERANCES
 MAT. DEC.
 (WOOD) .XX ±.03 [.8mm]
 (OTHER) .XX ±.02 [.5mm]
 (ALL) .XXX ±.005 [.13 mm]
 FRACTIONS ±1/32 [.8 mm]

ANGLES
 ±1/2°