

Lumination® LED Luminaire

LPL Series Controller Box



BEFORE YOU BEGIN

Read these instructions completely and carefully.

⚠ WARNING / AVERTISSEMENT

RISK OF ELECTRIC SHOCK

- Turn power off before inspection, installation or removal.
- Properly ground electrical enclosure.

RISK OF FIRE

- Follow all NEC and local codes.
- Use only UL approved wire for input/output connections.
Minimum size 18 AWG (0.75mm²).
- Do not install insulation within 3 inches (76 mm) of luminaire top.

RISQUES DE DÉCHARGES ÉLECTRIQUES

- Coupez l'alimentation avant d'inspecter, installer ou déplacer le luminaire.
- Assurez-vous de correctement mettre à la terre le boîtier d'alimentation électrique.

RISQUES D'INCENDIE

- Respectez tous les codes NEC et codes locaux.
- N'utilisez que des fils approuvés par UL pour les entrées/sorties de connexion.
Taille minimum 18 AWG (0.75mm²).
- Maintenir une distance de 76 mm (3 pouces) entre le luminaire et l'isolant.

Save These Instructions

Use only in the manner intended by the manufacturer.
If you have any questions, contact the manufacturer.

This device complies with Part 15 of the FCC Rules. Operation is subject to the following two conditions: (1) This device may not cause harmful interference, and (2) this device must accept any interference received, including interference that may cause undesired operation. CAN ICES-005(A)/NMB-005(A)

Note: This equipment has been tested and found to comply with the limits for a Class A digital device, pursuant to part 15 of the FCC Rules. These limits are designed to provide reasonable protection against harmful interference when the equipment is operated in a commercial environment. This equipment generates, uses, and can radiate radio frequency energy and, if not installed and used in accordance with the instruction manual, may cause harmful interference to radio communications. Operation of this equipment in a residential area is likely to cause harmful interference in which case the user will be required to correct the interference at his own expense.

Prepare Electrical Wiring



Electrical Requirements

- The LED luminaire must be connected to the mains supply according to its ratings on the product label.
- Class 1 wiring should be in accordance with NEC.



Grounding Instructions

- The grounding and bonding of the overall system shall be done in accordance to local electric code of the country where the luminaire is installed.

Tools and Components Required

- Screwdriver
- UL Listed conduit connections per NEC/CEC for nominal conduit trade size 1/2" or 3/4"
- UL Listed wire connectors

Luminaire Installation

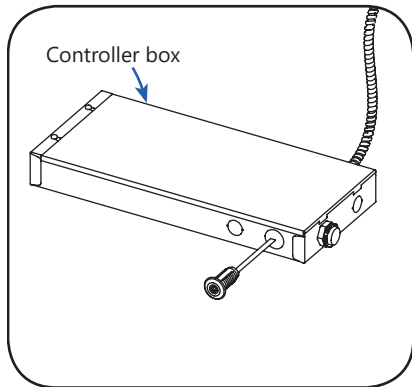

Part Identification

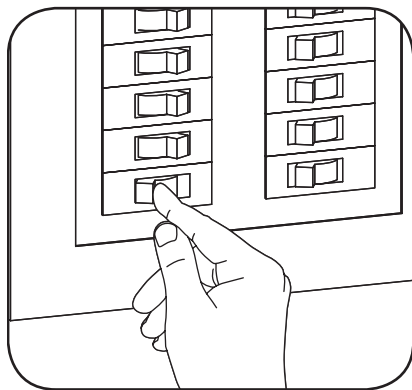

1 Disconnect incoming power to the fixture at the panel.

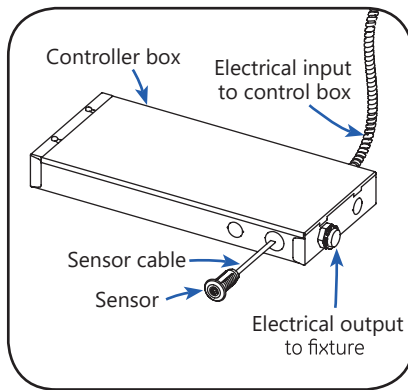

2 Open the knockout hole where electrical output to fixture, then install the conduit fitting on the controller box (Conduit fitting was in the bag of controller kit).

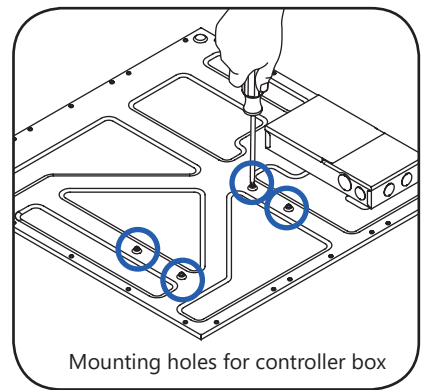

3 Remove screws on the back of luminaire.
NOTE: Keep the screws for later use.

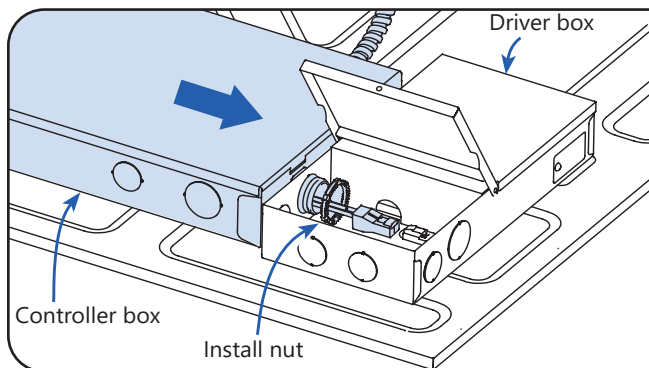

For LPL22B/ LPL24B

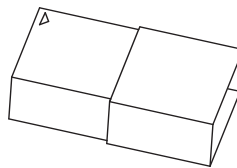

95028316 Female

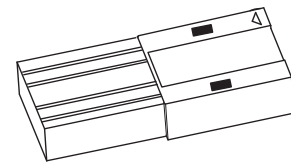

95028316 Male

Note: They are in the bag of the controller kit

4 Insert the conduit fitting to the driver box and screw the nut to connect them. Make sure all the electrical wires are inserted together into the driver box and connect the wires according to the appropriate wiring diagram on pages 6-7.

For LPL22B/ LPL24B:

Replace current EMBB LED input/output wire connector with 95028316(Female), 95028316(Male) for EMBB version and IOTA CP Series EMBB with Control version.

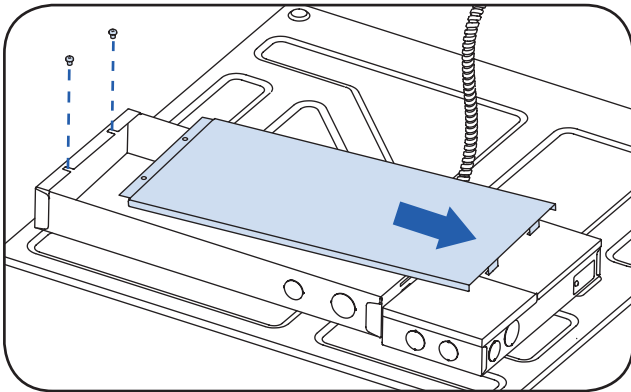

5 Remove the screws and open the control box cover by sliding it aside.
NOTE: Keep the screws for later use.

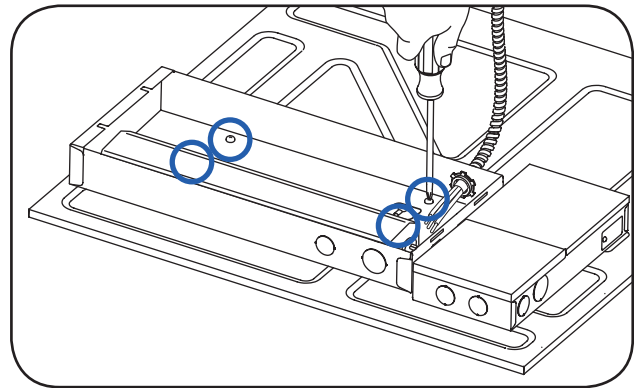

6 Fix the controller box to the back of the luminaire using the four available holes and the screws from step 3.

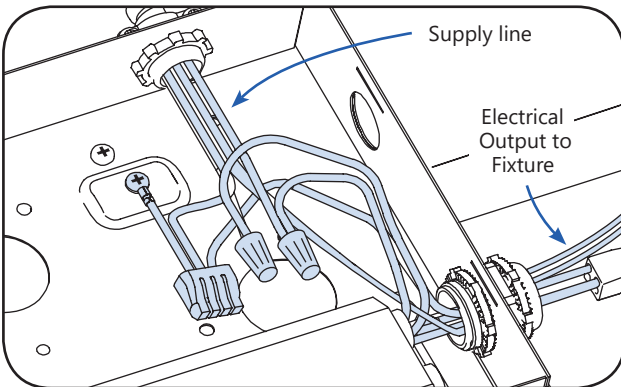

7 Make supply line connections inside the controller box assembly. Refer to the appropriate wiring diagram on pages 6-7 to identify proper connections. Fix the controller box cover by the screws and star washers.

8 Position and install sensor in the ceiling using provided hardware.

LPL22C/ LPL24C

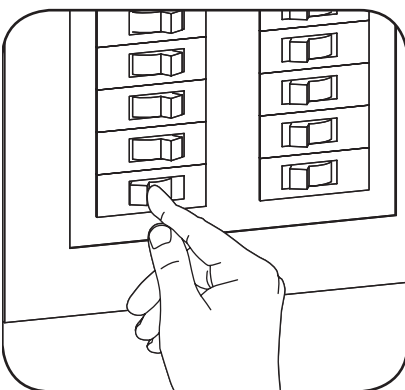

1 Disconnect incoming power to the fixture at the panel.

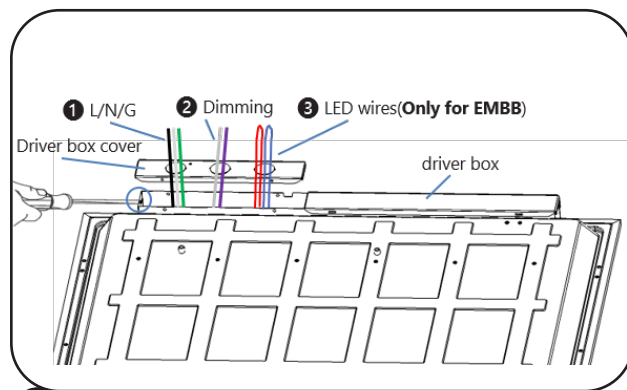

2 Remove the screw and open the driver box cover by sliding it upside, then open knockout hole **1 2** for None-EMBB or **1 2 3** for EMBB, after that, make these wires from driver through knockout hole:
1 Input line(L, N), Grounding
2 Dimming cable(Violet, Grey)
3 LED wire(LED Output, LED Input): Only for EMBB

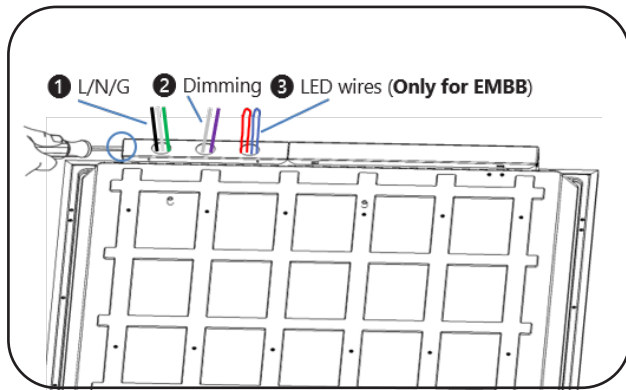

3 Install driver box cover back to driver box and fix it with screw while keeping these wires outside of driver box.

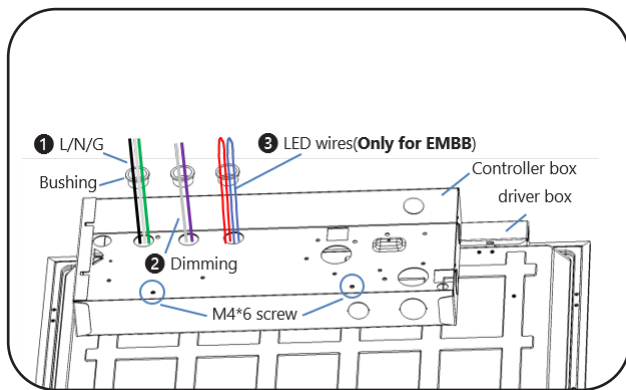

5 Install controller box on the back of the luminaire by keeping 2 holes of controller box matching with 2 nuts of luminaire housing back, set the knockout holes align between controller box and driver box while making wires through them, then fix controller box with M4*6 screws (M4*6 screws are in the bag of control kit). Insert bushing into knockout holes, and wires go through them (Bushings are in the bag of control kit).

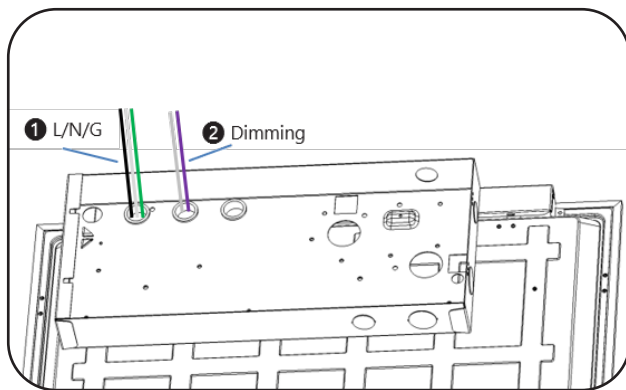

6-A **None-EMBB version:**
Make sure all the electrical wires are connected according to the appropriate wiring diagram on pages 6-7.

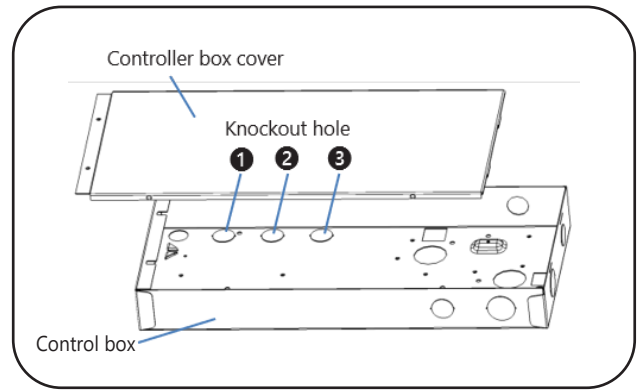

4 Remove the screws and open the controller box cover by sliding it aside, then open knockout hole 1 2 for None-EMBB or 1 2 3 for EMBB.

NOTE: Keep the screws for later use.

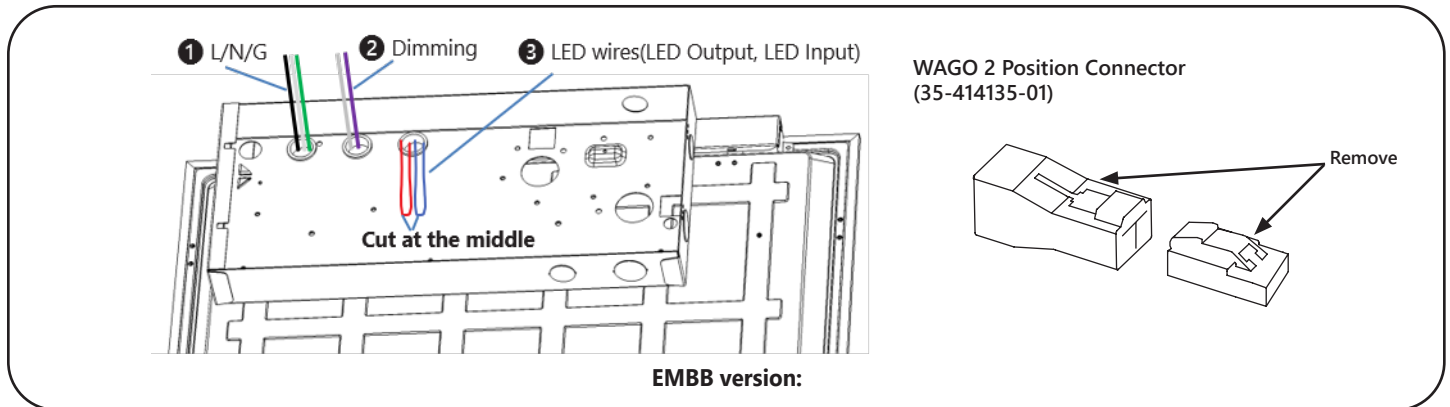

6-B

EMBB version:

Make sure all the electrical wires are connected according to the appropriate wiring diagram on pages 6-7. First, cut LED wires(LED Output, LED Input) at the middle, strip the wire tips by 10mm. Second, remove WAGO 2-position connectors from EMBB LED wires as above right view. Third, connect LED wires according to the appropriate wiring diagram on pages 6-7 with UL listed wire nuts. Finally, make sure all the electrical wires are connected according to the appropriate wiring diagram on pages 6-7.

⚠ Attention:

Make sure EMBB wiring is correct according to the appropriate wiring diagram on pages 6-7, otherwise EMBB function will fail.

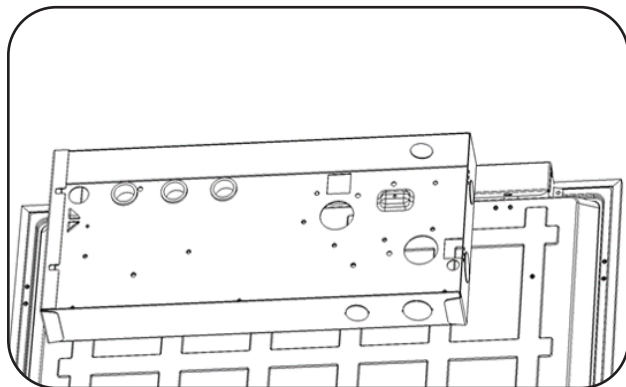

7

Make supply line connections inside the controller box assembly. Refer to the appropriate wiring diagram on pages 6-7 to identify proper connections. Fix the controller box cover by using the screws from step 4.

Wiring Diagrams

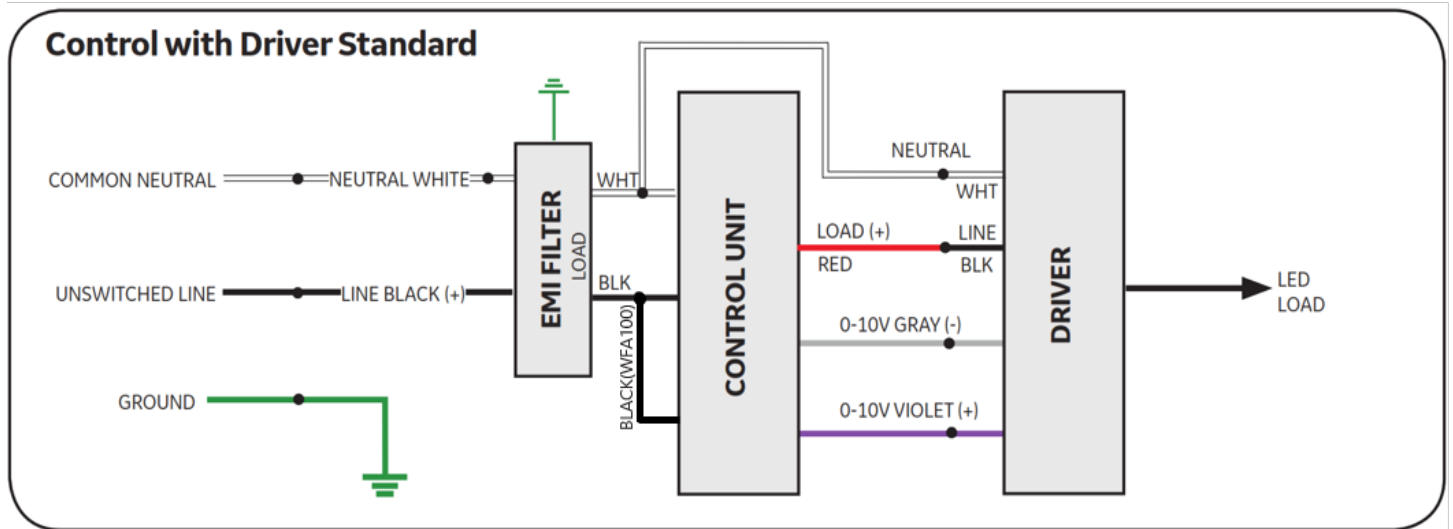
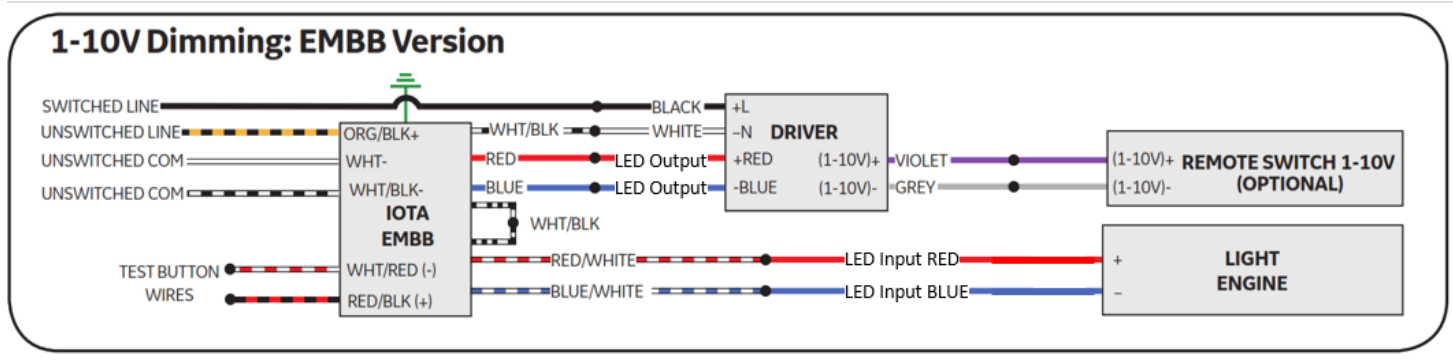
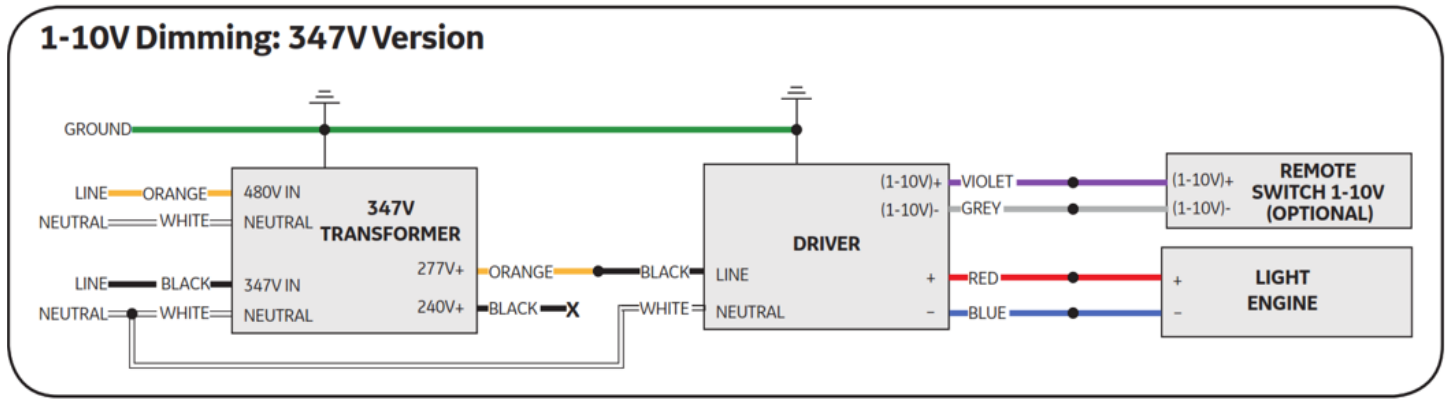
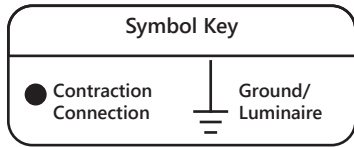

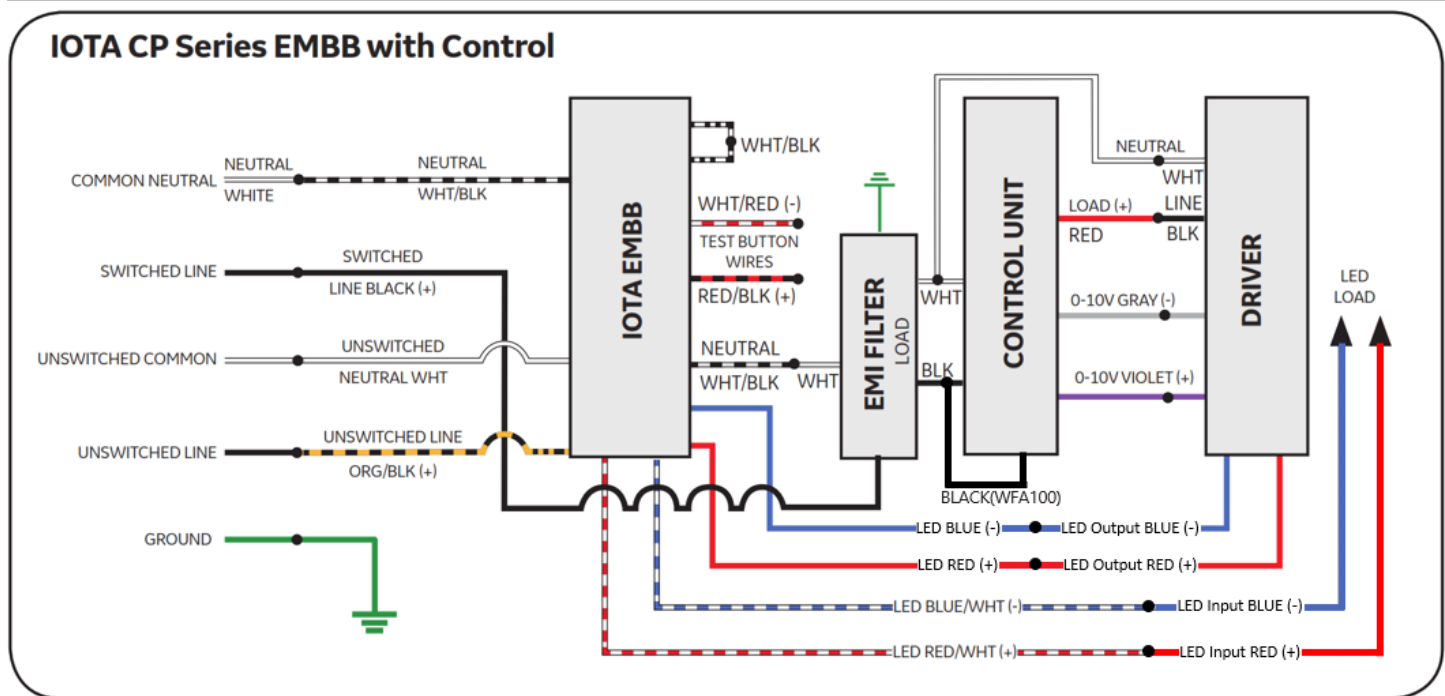
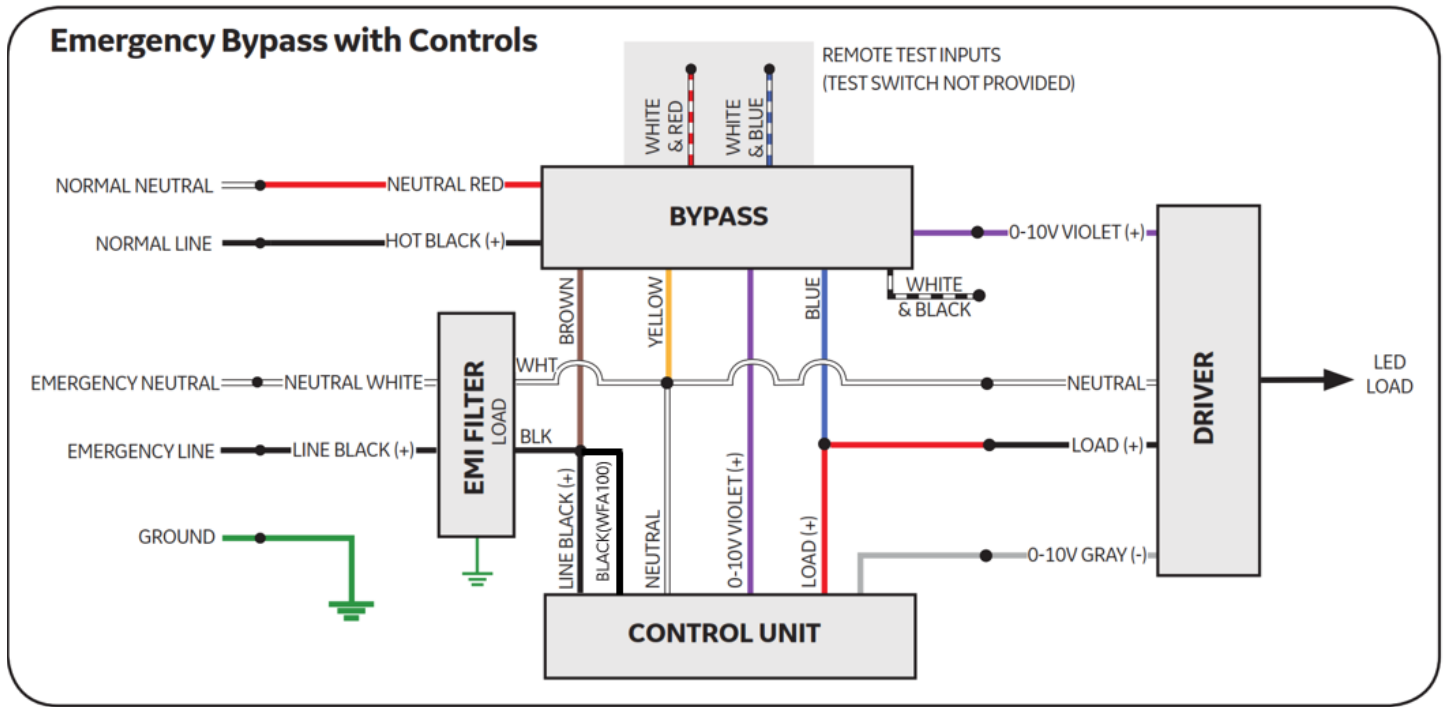

NOTE: For further information refer to EMBB installation instructions by searching for proper model number at www.iotaengineering.com

Electrical Connections



LABELS: The labels are in a small plastic bag and can be visible either on the control unit itself or near the fixture labels on the outside of the luminaire. These labels can be left in the same visible spot, or they can be placed in an area that is easy to access for easy identification.

Daintree Module G Controller



Node fixture identification labels in small plastic bag. Label to be used for customer floor plan or records.

LABELS: The labels are in a small plastic bag and can be visible either on the control unit itself or near the fixture labels on the outside of the luminaire. These labels can be left in the same visible spot, or they can be placed in an area that is easy to access for easy identification.

EMERGENCY BYPASS OPTION

Connect the BLACK and RED wires from the fixture to the normal, non-emergency AC wires to detect whether the fixture is in emergency mode.

NOTES:

- See diagram to right for wire colors and descriptions.
- Self-Test Input must be from same branch circuit as normal neutral and normal hot.
- Remote test switch is not provided.
- Remote test input is performed when input is CLOSED.

* For further information on the bypass unit, refer to www.functionaldevices.com

