

# SONDER

## LIVING

## CHARLIE DINING TABLE

Thank you for choosing this quality product. Be sure to check all packaging materials carefully for small parts that may have become loose during shipment and place all parts on a non-abrasive surface.

**IMPORTANT** :These parts can be cumbersome and heavy to some people, therefore the assistance of two or more people is recommended in order to prevent personal injury and ensure the furniture is not damaged during the assembly Process.

### PART LIST

A [1] TABLETOP









B [2] LEGS

C [1] STRETCHER

### INSTRUCTIONS

1. Place the leg (B) upright. Secure the threaded rod (1) to the fixed nut in the leg (B) by simply turning it manually. Gently, lay the table top (A) upside down on a soft flat surface. Place the leg upright and align the leg with the rails underneath of the table top. Put the leg (B) up against the top (A) so the threaded rods (1) go through the bore holes. Insert curved washer (2), lock washer (3) and place hex nuts (4) on threaded rod (1) then tighten the hex nuts (4) with wrench (5) provided, as illustrated in **FIGURE 01**.
2. Repeat the above procedure with the other leg (B) to attach it to the top (A).

### HARDWARE LIST

NO	DESCRIPTION	QTY
1	 THREADED ROD	4
2	 CURVED WASHER	4
3	 LOCK WASHER	6
4	 HEXAGONAL NUT	4
5	 SPANNER WRENCH	1
6	 ALLEN HEAD BOLT	2
7	 PLAIN WASHER	2
8	 ALLEN WRENCH	1

**FIGURE 01**

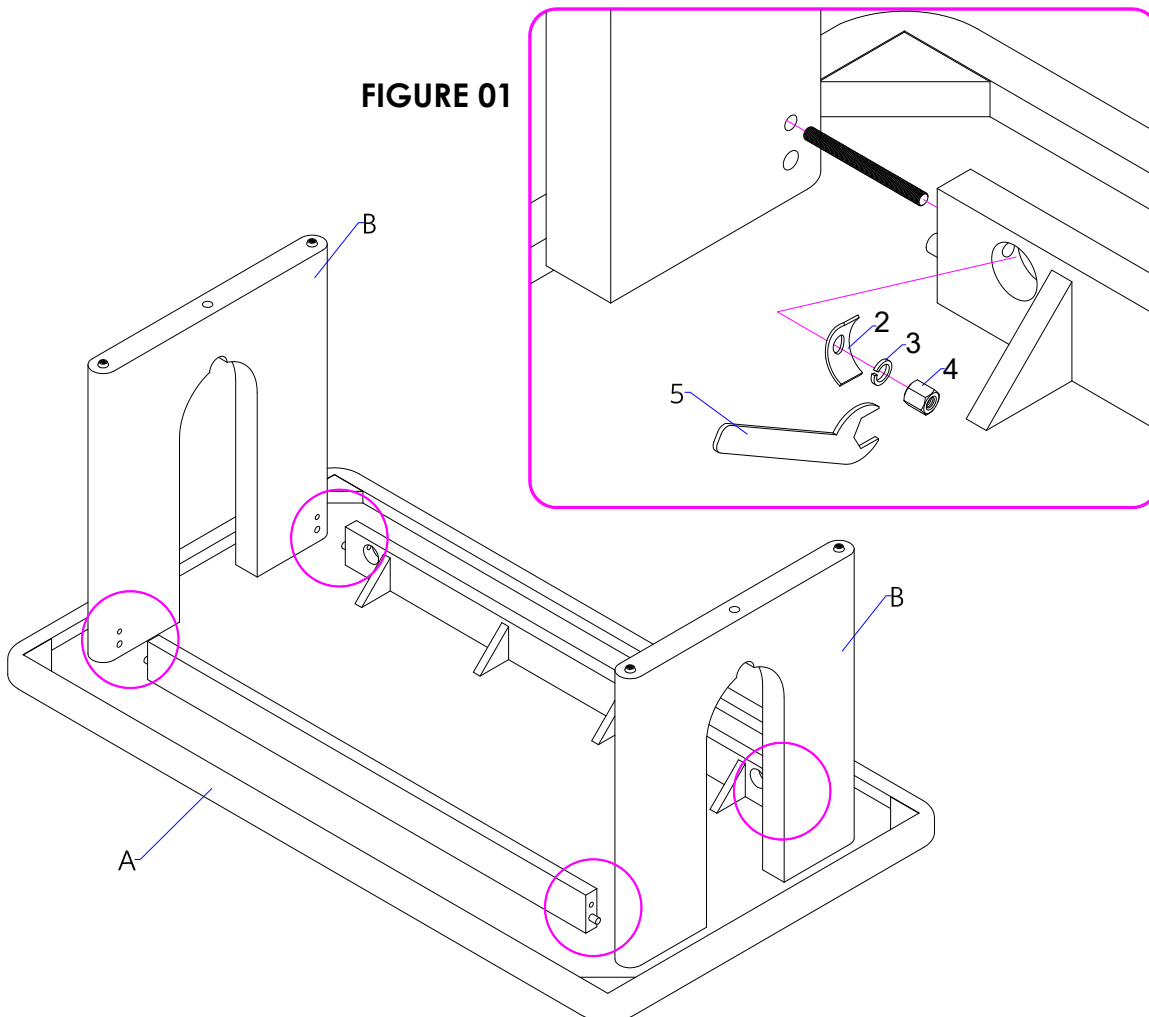

3. Attach the Stretcher (C) into the legs by using Allen bolts (6) together with Lock washer (3) and Flat washer (7). DO NOT OVERTIGHTEN. See **FIGURE 02**.
4. After assembly, turn the table upright on a flat surface. Check the table leveling, and adjust the levelers at the bottom of the base if necessary. See **FIGURE 03**.

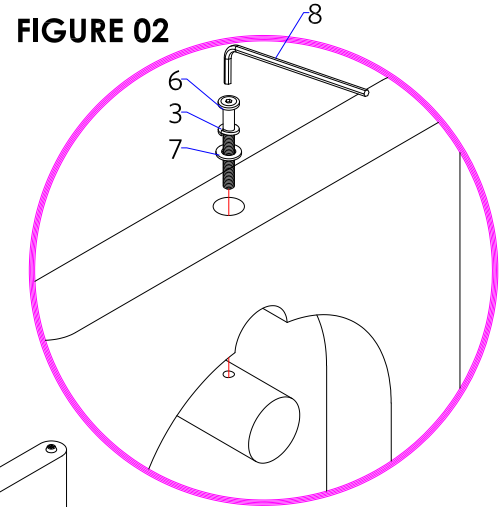
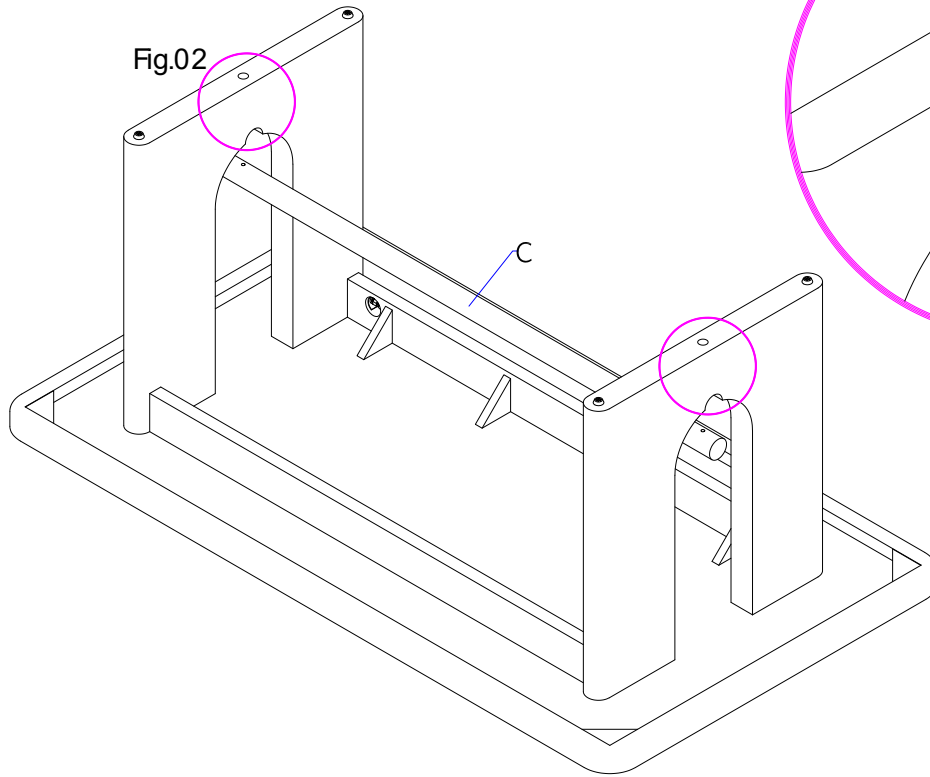

**FIGURE 03**

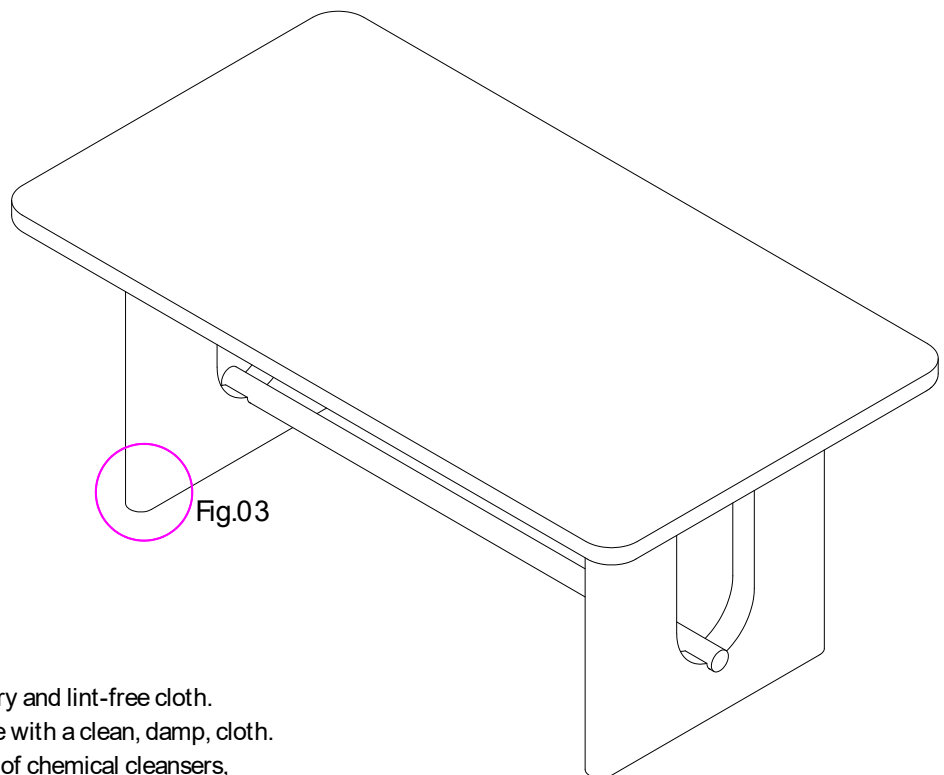
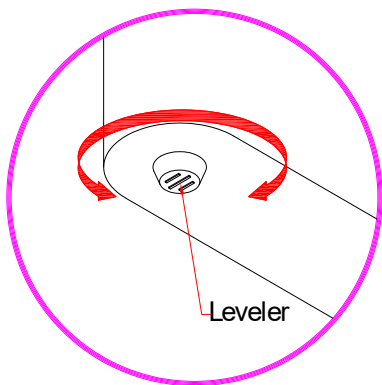

**CARE INSTRUCTIONS**

1. Dust often using a clean, soft, dry and lint-free cloth.
2. Blot spills immediately and wipe with a clean, damp, cloth.
3. We do not recommend the use of chemical cleansers, abrasives or furniture polish on our lacquered finish.

**IMPORTANT SAFETY INSTRUCTIONS**

1. Please read all instructions carefully before assembling.
2. For your safety, assembly by two or more adults is strongly recommended.
3. Keep instructions for future use.
4. Use only vendor supplied hardware to assemble. Using unauthorized hardware could jeopardize the structural integrity of the item.