

CUSTOMER DRAWING

This drawing is the property of Rev-A-Shelf (RAS) and is disclosed in confidence to the extent its subject matter is original to RAS. Any vendor receiving this drawing from RAS shall hold and use this drawing for the sole benefit of RAS and shall not disclose it to, or use or reproduce it for any third party, or perform any act adverse to the interest of RAS with respect to this drawing without the express written permission of RAS. Vendors shall not revise any physical, dimensional or performance characteristic unless authorized by Rev-A-Shelf Engineering.

REV.	DATE	BY	DESCRIPTION OF CHANGE

INCH [MM]	AMERICAN PROJECTION 	BY	DATE	REV-A-SHELF, INC.
		DRAWN	DKK 10-29-18	
TOLERANCES		MATERIAL	DRAWING NO.	SCALE
MAT.	DEC.	FINISH	432-WFBBSC42-6C	0.188
(WOOD)	.XX ±.03 [.8mm]		PART NO.	432-WFBBSC42-6C
(OTHER)	.XX ±.02 [.5mm]			
(ALL)	.XXX ±.005 [.13 mm]			
FRACTIONS ±1/32 [.8 mm]				

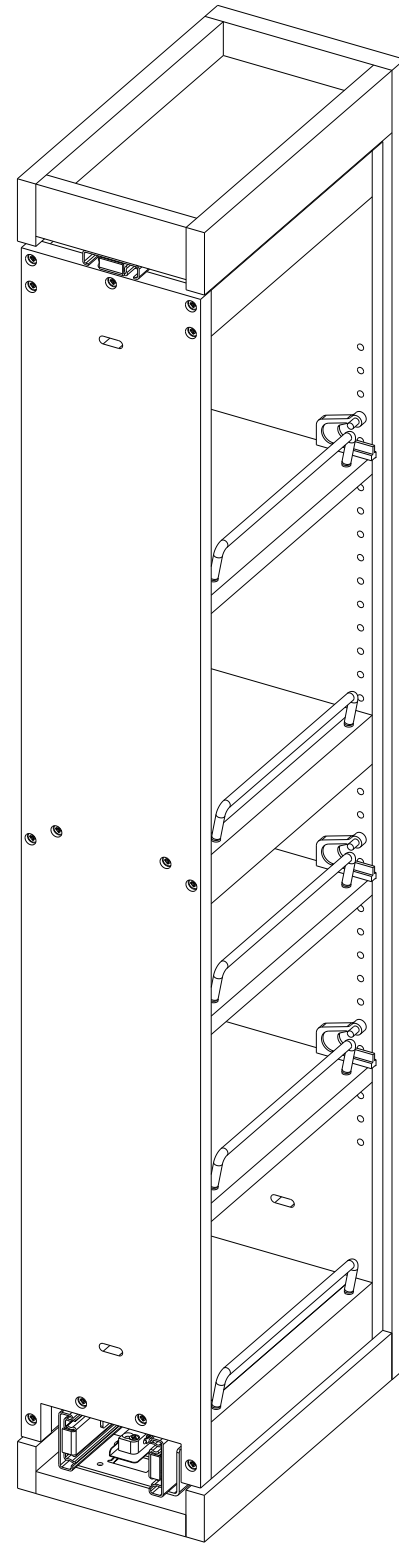

PART DIMENSIONS	
WIDTH	6.00 [152,4]
DEPTH	11.13 [282,6]
HEIGHT	42.00 [1066,8]

MCO: N/A (PRODUCT INSTALLS BETWEEN TWO CABINETS)

PRODUCT MAX WEIGHT RATING
BMHA STANDARDS

SLIDE SPECIFICATIONS				
SLIDE TYPE	BALL BEARING	SLIDE EXTENSION	FULL	MAX WEIGHT RATING
SLIDE CLOSING	SOFT CLOSE	SLIDE LENGTH	267MM	
SLIDE MOUNTING	N/A	SLIDE FINISH	ZINC	100 LB

CUSTOMER DRAWING

This drawing is the property of Rev-A-Shelf (RAS) and is disclosed in confidence to the extent its subject matter is original to RAS. Any vendor receiving this drawing from RAS shall hold and use this drawing for the sole benefit of RAS and shall not disclose it to, or use or reproduce it for any third party, or perform any act adverse to the interest of RAS with respect to this drawing without the express written permission of RAS. Vendors shall not revise any physical, dimensional or performance characteristic unless authorized by Rev-A-Shelf Engineering.

REV.	DATE	BY	DESCRIPTION OF CHANGE

INCH [MM]	AMERICAN PROJECTION 	DRAWN	BY	DATE	REV-A-SHELF, INC.
			DKK	10-29-18	
			SIZE	6" 432 WALL FILLER 42" TALL	
			MATERIAL	DRAWING NO.	SCALE
			FINISH	432-WFBBSC42-6C	0.188
				PART NO.	SHEET OF
				432-WFBBSC42-6C	2 OF 2

TOLERANCES  
 MAT. DEC.  
 (WOOD) .XX ±.03 [.8mm]  
 (OTHER) .XX ±.02 [.5mm]  
 (ALL) .XXX ±.005 [.13 mm]  
 FRACTIONS ±1/32 [.8 mm]

ANGLES  
 ±1/2°