

BLUEY

**3-in-1 Ride-On
AGES 1.5-4**

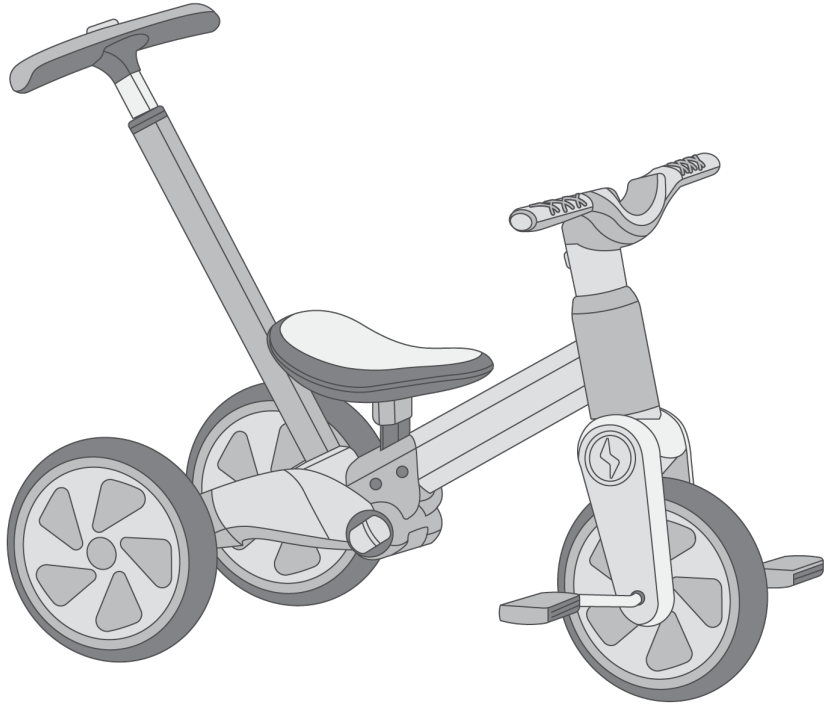

NOTE: Illustrations in this manual are for reference purposes only and may not reflect the exact appearance of the actual product. Specifications are subject to change without notice. This manual contains important safety, performance and maintenance information. Read the manual before taking your first ride or allowing your child to ride your new 3-in-1 ride-on. Keep the manual handy for future reference.

TABLE OF CONTENTS

A	Introduction, Safety and Warnings	3
B	Before You Begin Assembly	6
C	Parts Diagram	7
D	Assembly	8
E	Before Each Ride	13
F	Limited Warranty	14

SPECIFICATIONS

Suitable Age	1.5-4 years
Total Capacity	Up to 50 lb (23 kg)
Size	38.19 x 13.39 x 35.43 in

ABOUT THIS MANUAL:

This manual was written to help you get the most performance, comfort, enjoyment and safety when your child is riding his or her new 3-in-1 ride-on. It is important for you to understand your child's new 3-in-1 ride-on, how your child should use it and what you need to do to keep your child safe. This manual contains many "Warnings" and "Cautions" concerning the consequences of failing to maintain or inspect your 3-in-1 ride-on. Because any incident can result in serious injury or even death, we do not repeat the warning of possible serious injury or death each time such a warning is mentioned.

RIDE AT YOUR OWN RISK AND ALWAYS USE COMMON SENSE:

This manual contains many warnings and cautions concerning the consequences of failing to inspect, maintain or properly use your 3-in-1 ride-on. Because any fall can result in serious injury or even death, we do not repeat the warning of possible serious injury or death each time such a possibility is mentioned in this manual or the risk of falling leads to a warning. Always wear a properly fitted helmet. Always wear appropriate clothing and shoes. Never ride barefoot or in sandals and make sure that shoelaces or other fasteners are tied and kept away from the wheels of the 3-in-1 ride-on.

⚠️ GENERAL WARNING: Riding a 3-in-1 ride-on can be a dangerous activity, even under the best of circumstances. Proper maintenance of your new 3-in-1 ride-on is your responsibility and helps reduce the risk of injury. Certain conditions may cause components to fail without fault of the manufacturer. The 3-in-1 ride-on can and is intended to move, and it is therefore possible to lose control, fall off and/or get into dangerous situations that no amount of care, instruction or expertise can eliminate. If such a thing does occur, your child can become seriously injured or die, even when using safety equipment and other safety precautions. The following manual is ONLY a guide to assist you.

⚠️ WARNING: TO AVOID SERIOUS INJURY—Continuous adult supervision required; never use near motor vehicles; never use near streets, swimming pools, hills, steps, or sloped driveways; always wear a helmet and shoes when using the 3-in-1 ride-on; allow only one rider at a time.

⚠️ WARNING: This 3-in-1 ride-on is intended to be ridden on smooth, level ground. Do not ride in loose dirt, sand, or gravel. Do not ride in rain, snow, or mud.

⚠️ WARNING: Adult assembly required. Choking hazard to children under the age of 3 years – contains small parts prior to assembly.

USE, OPERATION, & SAFETY

You should read this manual completely before letting your child ride your new 3-in-1 ride-on. The age grade of 2 to 5 years old is based on United States government guidance on child development and appropriate toys, but young children are all different. If your child walks and runs with confidence, then the 3-in-1 ride-on will help your child develop balancing skills and learn about steering. **The 3-in-1 ride-on has no brake.** To stop, your child merely stops pedaling and stands up. You can not expect your child to understand how difficult it is to stop on hills or at speed, and your close supervision and sound limits about speed and grade are required for your child's safety. So encourage play and having fun with the 3-in-1 ride-on, but keep it on flat surfaces or gentle slopes, always wear shoes (never barefoot, sandals or flip flops), and avoid traffic and pedestrians.

Remember only you are the best judge of whether your child is at the appropriate development stage for safe play with the 3-in-1 ride-on. Stopping is obviously very important. The seat on the 3-in-1 ride-on is low to promote learning balance skills and to keep both of your child's feet close to the ground. Adjust the seat for comfort, but no higher than what will allow your child to have both feet on the ground at the same time while seated.

Always have your child wear a properly fitted helmet and appropriate clothes and shoes. Additional safety equipment including knee pads and elbow pads can also be used. The helmet is not only a good idea but required in many communities. To protect your child, the helmet must comply with CPSC, 16 CFR Section 1203 requirements and be worn correctly.



CORRECT FITTING

Make sure your helmet covers your forehead.



INCORRECT FITTING

Forehead is exposed and vulnerable to serious injury.

SAFE RIDING PRACTICES & WARNINGS

In Balance Bike Mode, the 3-in-1 ride-on is intended to allow children to learn at their own pace while feeling safe that they are not going to fall. In a controlled environment, have them start by sitting on the 3-in-1 ride-on and pushing with their feet. As shown in this manual, your child can also use the 3-in-1 ride-on in Tricycle Mode. Your responsibility is to set limits on speed and appropriate location for play. Be aware that young children often can master riding, and still will lose their balance and fall while at play. So part of your supervision is that they not leave the 3-in-1 ride-on or other toys around the ground where they play as they may fall on them. It is also your responsibility to maintain the 3-in-1 ride-on after correctly assembling it. Children should be made aware of all possible riding hazards and correct riding behavior before they take off on their 3-in-1 ride-on! Please explain to them as often as necessary:

- Always wear a properly fitted helmet.
- Always keep the chin strap on the helmet securely buckled.
- Observe the age and weight limitations on the cover of this manual.
- Never have more than one rider and never try to tow anything.
- Do not ride at night.
- Do not ride in wet weather. Wet weather impairs traction, stopping ability, and visibility.
- Obey all applicable, local laws when riding the 3-in-1 ride-on.
- Do not ride near swimming pools, ditches or drop offs.
- Do not ride if parts are broken or worn until fixed or replaced by your parent.
- Always ride on smooth surfaces or gentle slopes and avoid too much speed.
- Do not ride on surfaces with sand, gravel, dirt, leaves, or other debris.
- Do not ride on streets, around cars, on hills, barefoot, or in skateboard or vehicle traffic.
- Speed is a danger. This product has no brake. Avoid hills, stunts, jumps, and bumps.
- Avoid sharp turns, bumps, drainage grates, trick stages, ramps, half pipes, skateboard parks, and empty swimming pools.



B

BEFORE YOU BEGIN ASSEMBLY

The 3-in-1 ride-on is to be assembled by an adult. As shipped in the box it is partially assembled and contains potentially hazardous sharp edges and points on screws and axle rods. The box contains a package of small parts, cap nuts and fasteners that pose a swallowing hazard to small children. Assemble the 3-in-1 ride-on without your child's help and keep these hazards away from your child until assembly is complete.

ESTIMATED ASSEMBLY TIME:

You should allow approximately 10 minutes for assembly.

Before assembling your 3-in-1 ride-on, make sure you have all parts shown in the diagram on page 7. The components of your 3-in-1 ride-on might differ. Some of the parts shown might be optional and not part of your 3-in-1 ride-on's standard equipment.

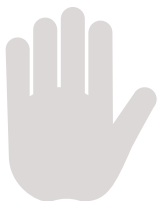

DO NOT RETURN THIS ITEM TO THE STORE

Please contact Dynacraft customer service for assistance.

[dynacraftwheels.com/contact](https://www.dynacraftwheels.com/contact) or 1-800-551-0032

If you experience a problem with this product, or are missing a part, please contact our customer service team at [dynacraftwheels.com/contact](https://www.dynacraftwheels.com/contact), rather than return this product to the store. Please identify all parts before assembly and save all packaging material until assembly is complete to ensure that no parts are discarded.

⚠️ WARNING: DO NOT USE NON-ORIGINAL OR NON-RECOMMENDED PRODUCTS WITH YOUR 3-in-1 ride-on. Altering of the original components or use of non-recommended replacement parts or accessories may or may not be compatible with the design may cause an unsafe condition resulting in serious injury or death. Doing so will also void your warranty. Contact our Customer Service Team for original replacement parts at [dynacraftwheels.com/contact](https://www.dynacraftwheels.com/contact).

- A. Handlebar x1
- B. Frame x1
- C. Front Wheel x1
- D. Pedal x2
- E. Rear Wheel x2
- F. Push & Steer Handle x1
- G. Seat x1

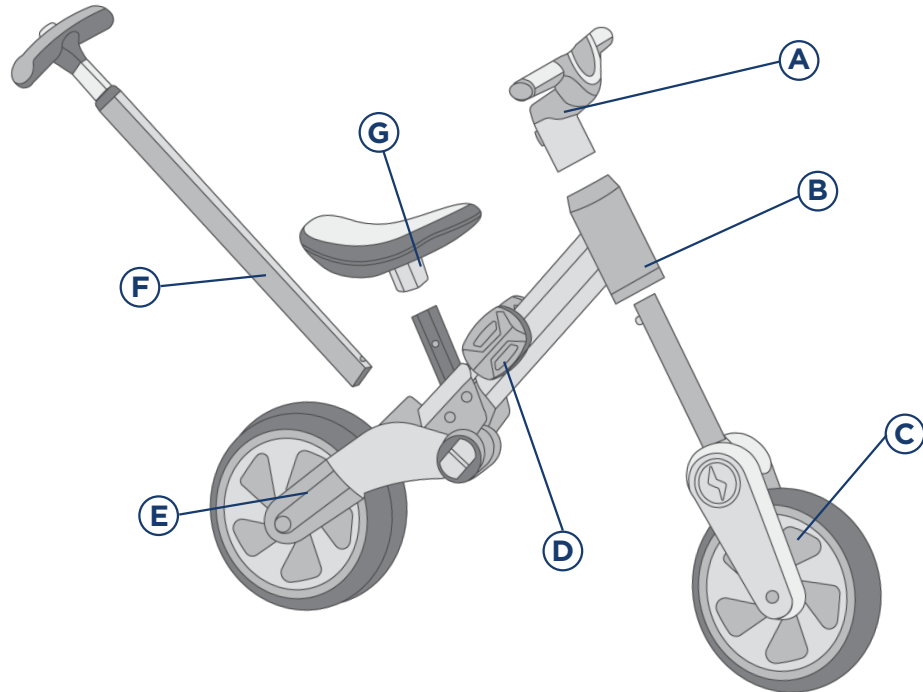

⚠ WARNING: Children can be harmed by small parts, sharp edges and sharp points in the 3-in-1 ride-on's unassembled state. In the unassembled state, this package contains small parts. Adult assembly is required; children should not handle parts or help in assembly of the 3-in-1 ride-on.

FRONT WHEEL

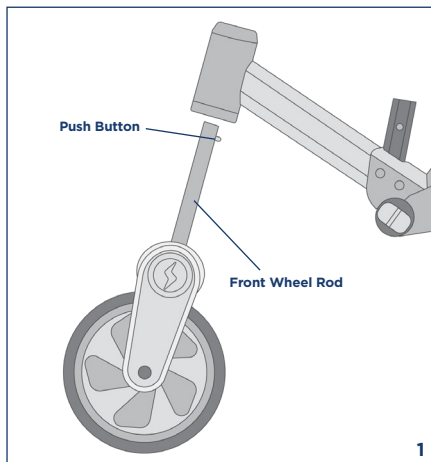

- Ensure the push button on the front wheel rod is facing backwards, then insert the front wheel rod into the head tube.

HANDLEBAR

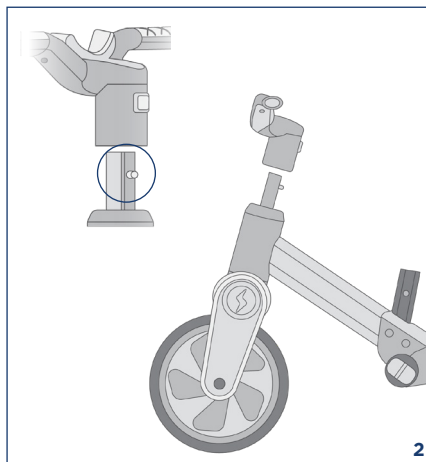

- Press the push button on the front wheel rod and insert the handlebar until it clicks.

SEAT

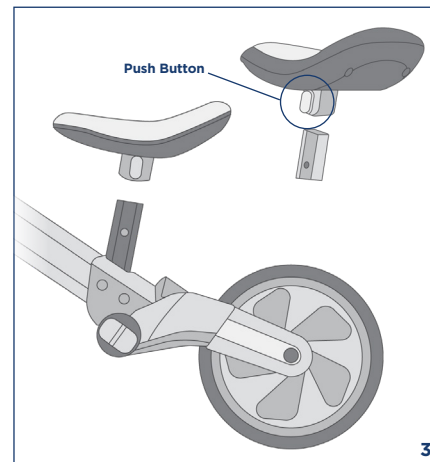

- Insert the seat into the seat post, press the push button until it clicks.

ASSEMBLY: PUSH TRICYCLE MODE

REAR WHEELS

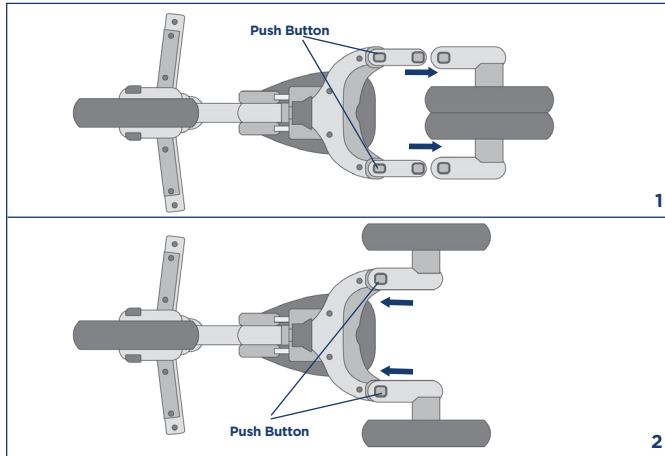

- Flip the previously assembled balance bike upside down.
- Press the push button and remove both rear wheels (1)
- Switch left and right rear wheels.
- Hold the push button down while inserting the rear wheels until they click.
- Check to ensure the push buttons are sitting in the correct place (2) and the wheels are secure.

PEDALS

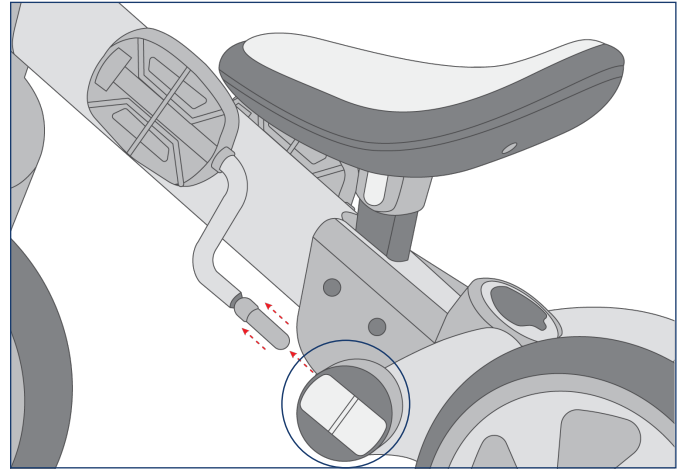

- Locate and press the push button to remove the pedal. Repeat this step for both pedals.

!WARNING: Always make sure that the wheels and other connections are secure before riding. Failure to do so may result in an accident and injury.

ASSEMBLY: PUSH TRICYCLE MODE

FRONT WHEEL

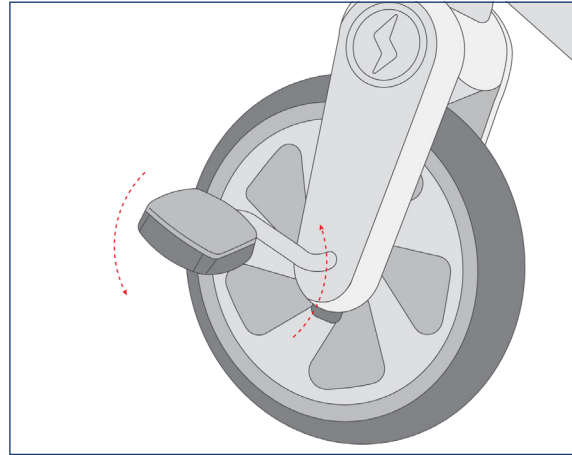
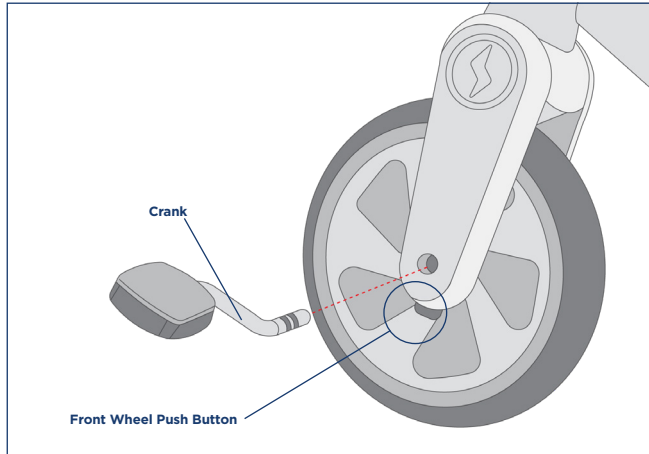

- On the front wheel, locate the push button and press while inserting the crank FULLY into the wheel axle.
- Hold the push button and turn the crank until it clicks. The crank is now locked and can drive the front wheel. Release the push button.
- Repeat this step on the other side.

ASSEMBLY: PUSH & STEER HANDLE

PUSH HANDLE

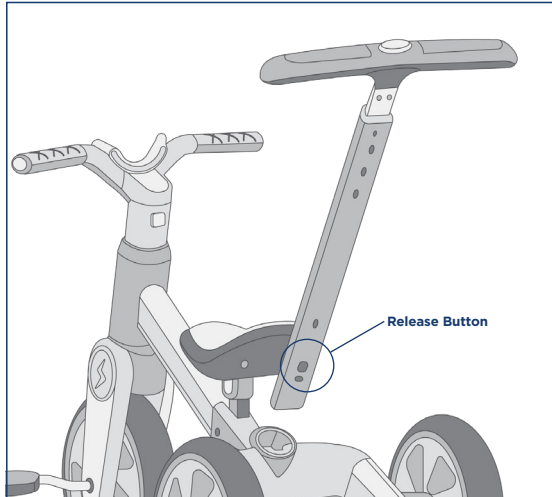

- Insert the handle into the frame until it clicks.
- To remove the push handle, press the release button.

HEIGHT LEVELS

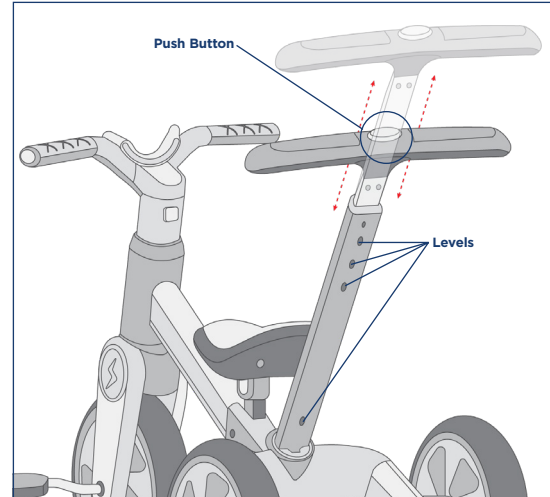

- The push handle has four height levels. Press the push button on the handlebar to adjust the height.

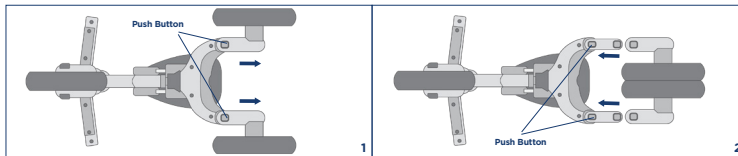

- To return to balance bike mode, flip the tricycle upside down and switch the left and right wheels.
- Press the push buttons until they click and make sure the wheels are securely attached.

! WARNING: Always make sure that the wheels and other connections are secure before riding. Failure to do so may result in an accident and injury.

MODES

Push Tricycle (with push handle)

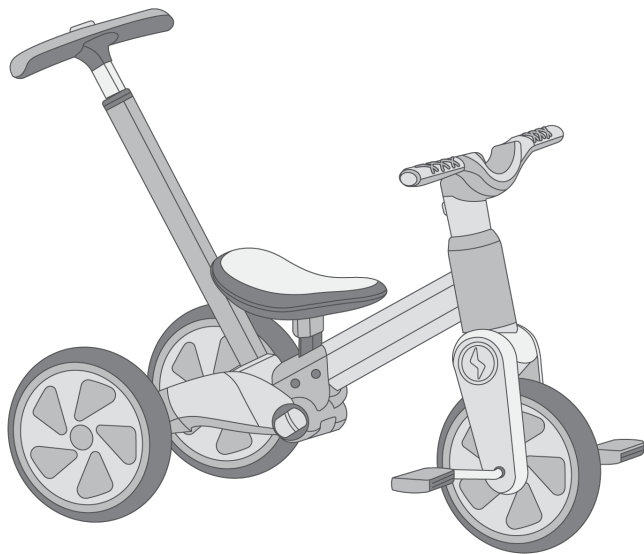

Tricycle

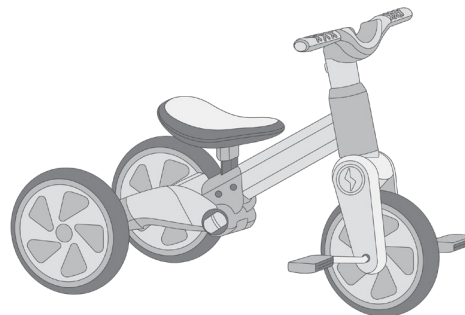

Balance Bike

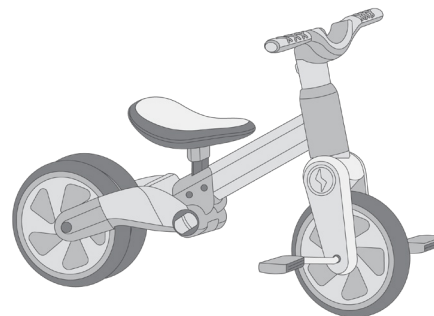

Check your 3-in-1 ride-on and its components against the following checklist. In addition, if you have a crash or accident, even a minor one, always inspect the 3-in-1 ride-on thoroughly before riding again:

- Check that wheels are straight.
- Check attachment of bolt-on wheels.
- Check handlebar and stem for signs of stress and fatigue.
- Inspect your tires for wear or damage.
- Check the attachment of the handlebar.
- Check the wheels to see if they can spin smoothly
- Periodically inspect the 3-in-1 ride-on for wear and damage.
- To clean the 3-in-1 ride-on, use mild soap and water solution and clean cloth. Rinse clean with water to remove soap residue.

! WARNING: A 3-in-1 ride-on that does not work properly can cause you to lose control and fall. Inspect the entire 3-in-1 ride-on thoroughly before every ride and do not ride it until any problem has been corrected.

This Limited Warranty (“Warranty”) extends only to the original retail purchaser, who must provide proof of purchase to validate any claim. As noted below, certain aspects of this Warranty can be extended free of charge to original retailer purchasers who also register their product using the provided online registration form. Proper registration via Dynacraft’s online registration form is the only way to obtain these noted extensions. This Warranty is not transferable to anyone else and is the only warranty for your Dynacraft product, to the extent permitted by law. No other express or implied warranty is given, and except to the extent prohibited by applicable law, any implied warranty of merchantability or fitness for a particular purpose on this product is hereby disclaimed. Part or model specifications are subject to change without notice. By purchasing and using your new 3-in-1 ride-on you agree to be bound by the terms of this Warranty as set out below. This Warranty is subject to change without notice.

What does this Limited Warranty cover? This Warranty covers all parts of the 3-in-1 ride-on to be free from defects in workmanship and materials. This Warranty is only effective if: the 3-in-1 ride-on is used under normal conditions for its intended purposes, by a person that properly fits and is capable of controlling the 3-in-1 ride-on; and the 3-in-1 ride-on receives all necessary maintenance and adjustments.

Useful Life: This 3-in-1 ride-on, like any other item has a useful life. A lifetime warranty on the frame does not mean and is not intended to imply that the 3-in-1 ride-on will last forever. The length of the useful life of this 3-in-1 ride-on will vary depending on the type of product, riding and storage conditions, and the care the 3-in-1 ride-on receives.

What is not covered by this Limited Warranty? This Warranty does not include labor and transportation charges. You, the original purchaser will be responsible for labor or transportation charges associated with the repair or replacement of the frame or other components covered under this Warranty. Those original purchasers who qualify for the extended version of this Warranty will have transportation charges waived for the duration of the Limited Warranty period.

The 3-in-1 ride-on frame and components have been manufactured for general transportation and recreational use by average riders, and the 3-in-1 ride-ons are not intended for trick riding, ramp riding, jumping, aggressive riding or any similar, extreme activities. This Warranty does not cover normal wear and tear, paint, rust, or normal maintenance items. This Warranty does not cover claimed defects, malfunctions, or failures that result from abuse, neglect, improper assembly, improper maintenance, lack of maintenance, alteration, misuse, crashes, or any similar damage.

LIMITED WARRANTY

This Warranty will be void if the 3-in-1 ride-on is ever: used in any competitive sport; used in any of the extreme activities, or similar activities mentioned above; installed with a motor or modified in any other way; ridden by more than one person at a time; rented or used for commercial purposes; or used in a manner contrary to the instructions in the Owner's Manual included with this product. Dynacraft will not be liable for incidental or consequential loss or damage, due directly or indirectly from use of this product.

For how long does this Limited Warranty last? The frame is warranted for the Useful Life of this 3-in-1 ride-on. All other components, with the exclusion of components subject to normal wear and tear are warranted for a period of one year after the original date of purchase. Defective components subject to normal wear and tear will be replaced by Dynacraft at no charge for a period of 30 days from the original date of purchase. For those original purchasers who qualify for the extended version of this Warranty, this period will be lengthened to 90 days from date of purchase. Components subject to the normal wear and tear exclusion include but are not limited to: tires; grips; and saddles.

What will Dynacraft do to honor this Limited Warranty? Dynacraft will replace, without charge to the customer, any frame or component confirmed to be defective with the same or a functionally equivalent part. You, the original purchaser will be responsible for any and all labor or transportation charges connected with the replacement or repair of the frame or other components covered under this Warranty.

How do you make a claim under this Limited Warranty? Warranty claims should be submitted via Dynacraft's online portal at dynacraftwheels.com/contact. Please have your proof of purchase available before contacting to validate your claim.

Products can be registered at dynacraftwheels.com/register.



DO NOT RETURN THIS ITEM TO THE STORE

Please contact Dynacraft customer service for assistance.

dyncraftwheels.com/contact or 1-800-551-0032

Please have the following information available:

Model Number

Example: 8000-00

Production Date

Example: MM.DD.YYYY

Serial Number

Example: DXXXX00000000

This information is provided on a white sticker located on your unit and is required to help us handle your request. Please do not remove the sticker from your unit.



Dynacraft BSC, Inc.
1501 Crossgate Road
Port Wentworth, GA 31407
©Dynacraft. All Rights Reserved.

Contact Customer Service
📞 dyncraftwheels.com/contact
☎ 1-800-551-0032

BLUEY TM and BLUEY character logos TM
& © Ludo Studio Pty Ltd 2018. Licensed by
BBC Studios. BBC logo TM & © BBC 1996

2026 Printed in China

BM312