



CUSTOMER NAME	
PROJECT NAME	
DATE	TYPE
CATALOG NUMBER	

LightGRID+ SERIES

LightGRID+ Wireless Gateway3

- Autonomously manages up to 500 fixture modules
- Astronomical and fixed time scheduling
- Uses Flash memory storage in order to withstand temperature, shock and vibrations
- Supports network connectivity via Ethernet connection (Standard) or optional cellular modem
- Enhanced surge protection 6kV / 3kA per ANSI C62.41-2002
- NEMA 4X (IP66) cabinet
- Secure communication using AES-128 encryption
- Optional cabinet heater for extreme cold environments

SPECIFICATIONS

CONSTRUCTION

- Compression molded fiberglass reinforced polyester construction with flush, solid/ opaque cover
- Standard: 10"L x 8"W x 4"H (Hammond PJU1084L)
- NEMA 4X (IP66 rated)
- Stainless steel hinges and lockable snap latches
- Supplied with pole and wall mounting brackets
- Weight: 6 lbs

ELECTRICAL

- 120-240 VAC; 50/60Hz²
- Power consumption: 10W maximum (Heater option 70W when in operation)
- Fuse: 5A
- Surge Protection: Protects against surges and transients per ANSI 62.41-2002 category C low (6kV, 1.2/50μS & 3kA, 8/20μS) standard Combo waves and (6kV, 100kHz) Ring wave

RADIO COMMUNICATIONS

- Radio Frequency Options: 2.4GHz ISM Band and 900MHz ISM Band

RADIO COMMUNICATIONS (CONTINUED)

- Recommended Range: Up to 300m / 1,000 ft between modules.¹ Communication range based on clear line of site. Range may vary widely depending on environmental factors.
- Transmit Power:
 - 2.4GHz: 63 mW (+18 dBm)
 - 900MHz: Up to 250 mW (+24 dBm)
- Receiver Sensitivity:
 - 2.4GHz: -101 dBm
 - 900MHz: -101 dBm

NETWORK AND SECURITY

- Ethernet: Static IP or DHCP protocol supported
- Cellular: Static/Dynamic Public IP or Static Private IP supported
- Secure Encrypted Communications: Military Grade AES-128 (and AES-256) encryption and certificate-based authentication
- Gateway passwords, certificates and keys securely stored
- Server API access protected and encrypted with X.509 certificates with proof of possession

OPERATION

- Autonomously manages a group of nodes
- GPS Accuracy: Horizontal position accuracy < 2.5 CEP

OPERATION (CONTINUED)

- Heater option available - Recommended when temperature is below 0°C

OPERATING ENVIRONMENT

- Relative Humidity: Up to 99% non-condensing (fully waterproof NEMA 4X enclosure)
- Ambient Temperature Range:
 - Without Heater: 0°C to +70°C
 - With Optional Heater: -40°C to +70°C

CERTIFICATIONS

- UL508A
- 2.4GHz Version: U.S. FCC (Digi XBee PRO 2.4GHz) Part 15.247 Class A: MCQ-PS2CTH, Canada IC: 1846A-PS2CTH, Europe CE: ETSI, Australia: C-TICK, Japan: TELEC
- 900MHz Version: U.S. FCC (Digi XBee PRO 900MHz) Part 15.247 Class A: MCQ-XB900HP
- This product qualifies as "designated country construction material" per FAR 52.225-11 Buy American-Construction Materials under Trade Agreements effective 5/27/2020

WARRANTY

- 5 year limited (Up to 10 year extended available)

Notes:

- 1 Antenna must be mounted vertically up or down.
- 2 277VAC and 347VAC operation requires step-down transformer – see Accessories



CUSTOMER NAME	_____
PROJECT NAME	_____
DATE	TYPE
CATALOG NUMBER	_____

ORDERING GUIDE

Example: WIR-GATEWAY3

CATALOG #

WIR-GATEWAY3	Radio	Options
Housing		
WIR-GATEWAY3 LightGRID+ Gateway Generation 3	Blank 2.4 GHz	Blank None
	9 900 MHz ¹	CM Cellular Modem ²
		H Heater
		CMH Cellular Modem and Heater ²
		CS Cellular Modem with SIM card ³
		CSH Cellular Modem with SIM card and Heater ³

Gateway Cellular Network Plans	
<input type="checkbox"/> WIR-GW3-CSNP-PBLC	LightGRID+ Gateway Generation 3 Cellular Service Network Plan - Public
<input type="checkbox"/> WIR-GW3-CSNP-PRVT	LightGRID+ Gateway 3 Cellular Service Network Plan - Private

Notes:

- 900 MHz Devices are MTO (Made To Order) - Contact Customer Service for Availability
- Cellular SIM card and service plan not included

Accessories	
<input type="checkbox"/> WIR-STPDNxFMR-277	LightGRID+ Gateway Stepdown Transformer - 277V TO 120V
<input type="checkbox"/> WIR-STPDNxFMR-347	LightGRID+ Gateway Stepdown Transformer - 347V TO 120V

DIMENSIONS

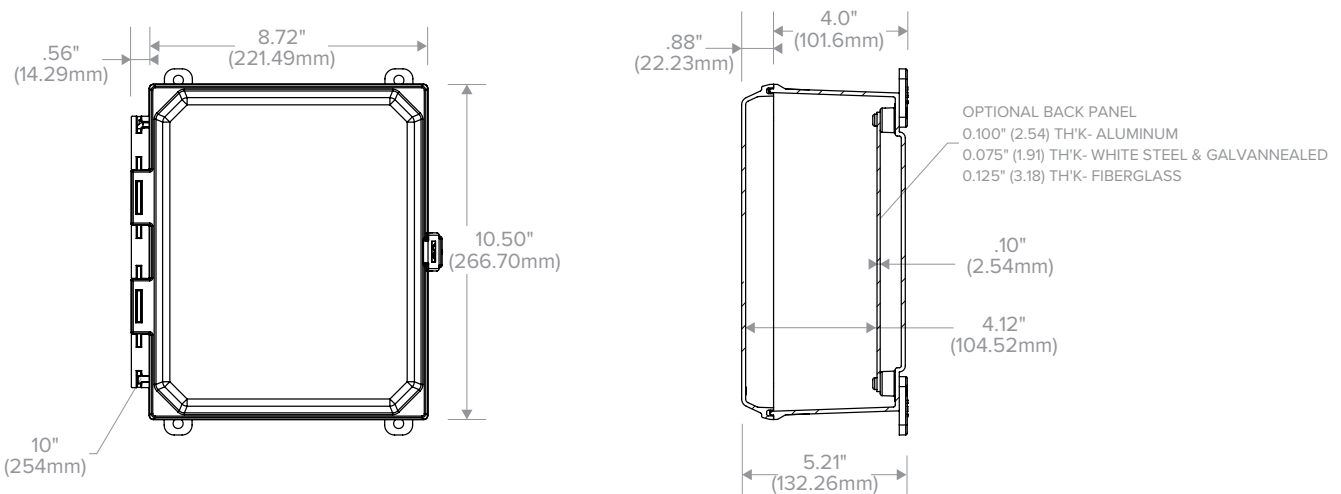

CUSTOMER NAME _____

PROJECT NAME _____

DATE _____

TYPE _____

CATALOG NUMBER _____

WIRING DIAGRAM

Access Point Notes:

- 1 In order to access into the Gateway, the Gateway must be connected to power at all times and connected into the client's network.
- 2 Logging into the Gateway is done by using the LightGRID+ Software Suite via the clients network.
- 3 A Gateway is necessary when programming presets

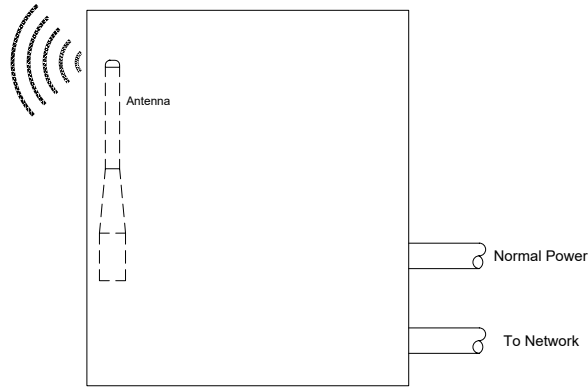

LightGRID+ Gateway - WIR-GATEWAY3