

TOP VIEW
SCALE 0.188

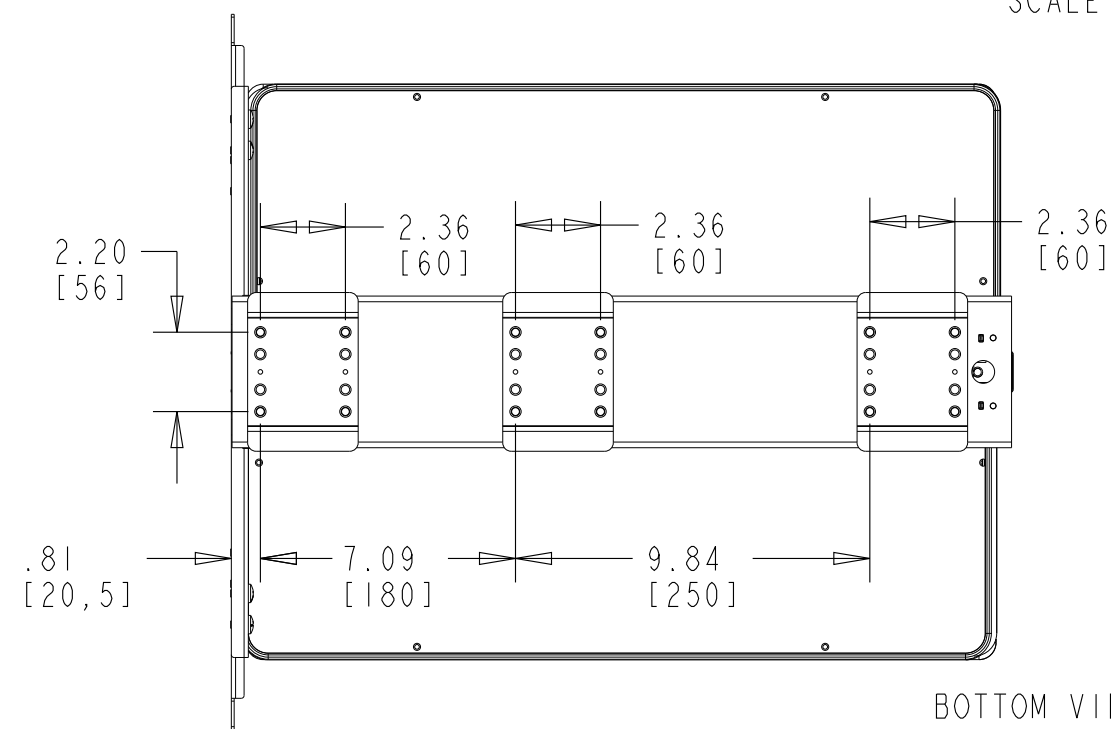

BOTTOM VIEW
SCALE 0.188

CUSTOMER DRAWING

This drawing is the property of Rev-A-Shelf (RAS) and is disclosed in confidence to the extent its subject matter is original to RAS. Any vendor receiving this drawing from RAS shall hold and use this drawing for the sole benefit of RAS and shall not disclose it to, or use or reproduce it for any third party, or perform any act adverse to the interest of RAS with respect to this drawing without the express written permission of RAS. Vendors shall not revise any physical, dimensional or performance characteristic unless authorized by Rev-A-Shelf Engineering.

REV.	DATE	BY	DESCRIPTION OF CHANGE
A	11-10-23	KRR	UPDATED MCO

INCH [MM]	AMERICAN PROJECTION	BY	DATE	REV-A-SHELF, INC.
		KRR	4-9-18	
DRAWN		MATERIAL	SIZE	SC SOLID BOTTOM PULLOUT PANTRY
TOLERANCES		FINISH	DRAWING NO.	SCALE
MAT. DEC. (WOOD) .XX ±.03 [8mm] (OTHER) .XX ±.02 [5mm] (ALL) .XXX ±.005 [13 mm] FRACTIONS ±1/32 [8 mm]			5358-16-XX	0.125
ANGLES ±1/2°			PART NO.	SHEET OF
			5358-16-XX	1 2

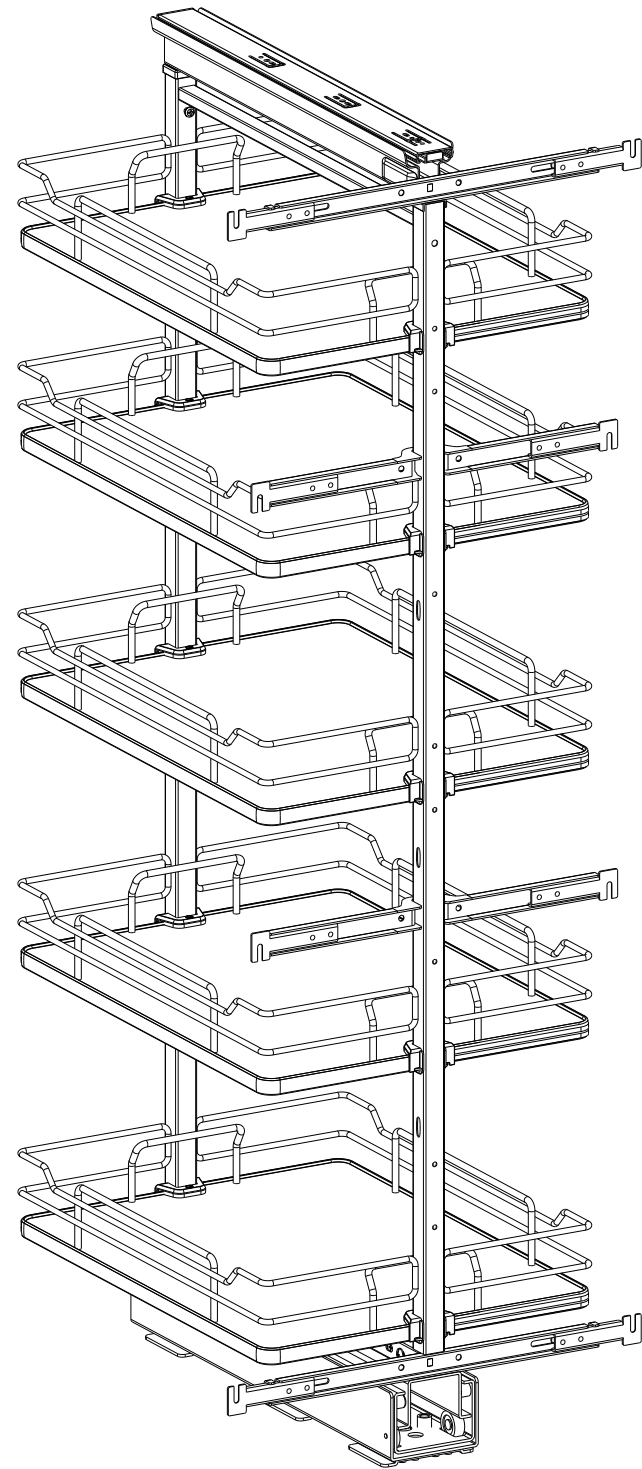

PART DIMENSIONS		
	MIN	MAX
WIDTH	16.00 [406]	19.87 [505]
DEPTH	21.72 [551,7]	
HEIGHT	58.25 [1479]	65.75 [1670]

MIN CABINET OPENING				
	FACE FRAME	FRAMELESS	INSET FACE FRAME	INSET FRAMELESS
WIDTH	16.50 [419]	16.50 [419]	16.50 [419]	16.50 [419]
DEPTH	21.75 [552,5]	21.75 [552,5]	22.50 [571,5]	22.50 [571,5]
HEIGHT	58.25 [1479]	58.25 [1479]	58.25 [1479]	58.25 [1479]

SLIDE SPECIFICATIONS				
SLIDE TYPE	HEAVY DUTY	SLIDE EXTENSION	20.87 [530]	MAX WEIGHT RATING
SLIDE CLOSING	SOFT CLOSE	SLIDE LENGTH	21.65 [550]	
SLIDE MOUNTING	BOTTOM	SLIDE FINISH	ZINC	250 LB

CUSTOMER DRAWING

This drawing is the property of Rev-A-Shelf (RAS) and is disclosed in confidence to the extent its subject matter is original to RAS. Any vendor receiving this drawing from RAS shall hold and use this drawing for the sole benefit of RAS and shall not disclose it to, or use or reproduce it for any third party, or perform any act adverse to the interest of RAS with respect to this drawing without the express written permission of RAS. Vendors shall not revise any physical, dimensional or performance characteristic unless authorized by Rev-A-Shelf Engineering.

REV.	DATE	BY	DESCRIPTION OF CHANGE
A	11-10-23	KRR	UPDATED MCO

INCH [MM]	AMERICAN PROJECTION 	DRAWN	BY	DATE	REV-A-SHELF, INC.
			KRR	4-9-18	
		MATERIAL		DRAWING NO.	SCALE
		FINISH		PART NO.	SHEET OF
		TOLERANCES MAT. DEC. (WOOD) .XX ±.03 [.8mm] (OTHER) .XX ±.02 [.5mm] (ALL) .XXX ±.005 [.13 mm] FRACTIONS ±1/32 [.8 mm]		5358-16-XX 0.125	
		ANGLES ±1/2°		5358-16-XX 2 OF 2	