

4

3

2

1

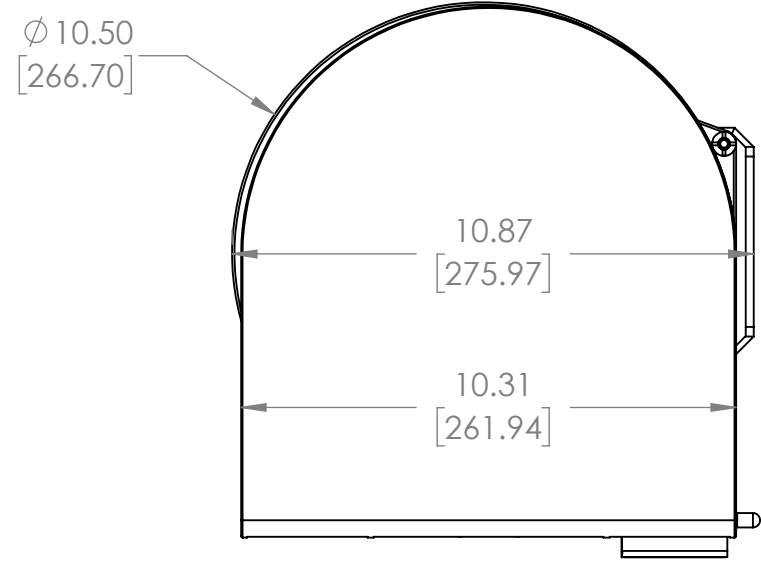

PART NO.	L1	L2
8-010212-14	14.22 [361.16]	12.94 [328.61]
8-010412-15	15.50 [393.74]	14.22 [361.16]
8-010314-15	15.50 [393.74]	14.22 [361.16]

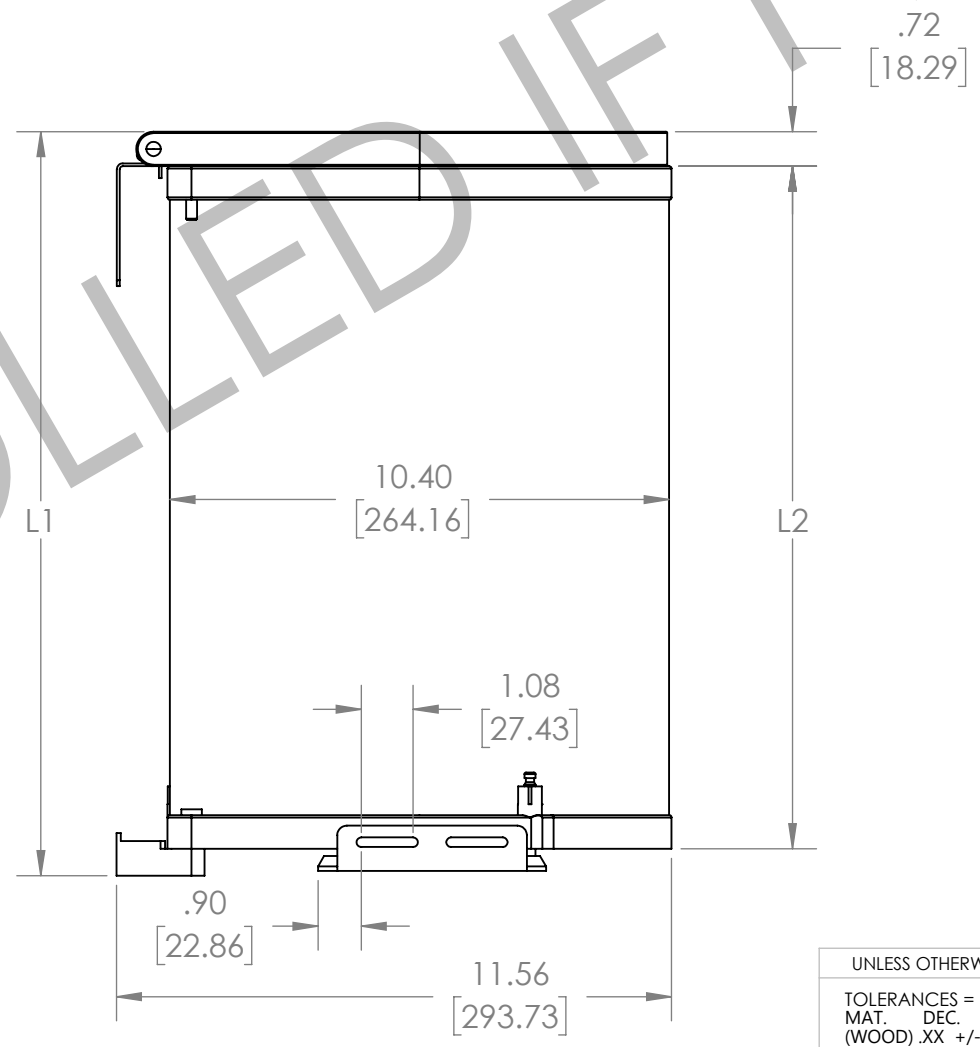
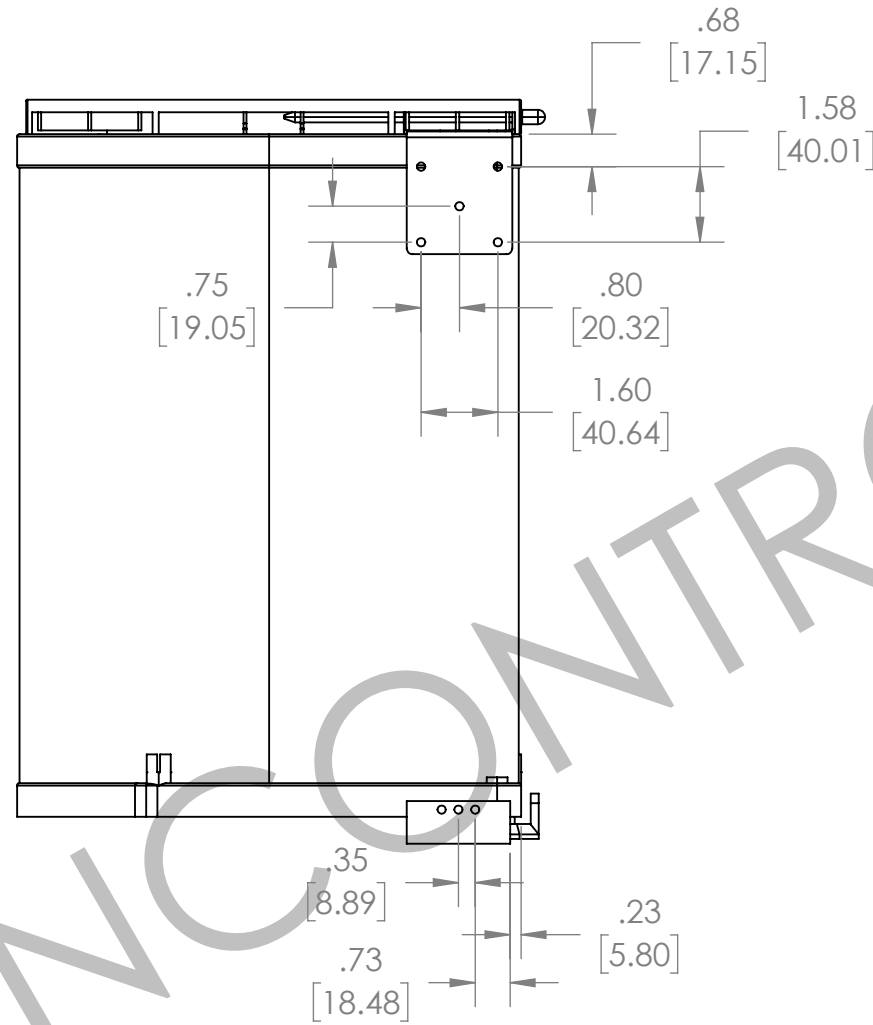

CUSTOMER DRAWING

# PIVOT OUT WASTE CONTAINER

PART NO. 8-010XXX-XX

SIZE **B** DWG. NO. 8-010XXX-XX\_CUST REV

SCALE: 1:4 WEIGHT: SHEET 1 OF 2

UNLESS OTHERWISE SPECIFIED:		
TOLERANCES = INCH/(MM)		
MAT. DEC.		
(WOOD) .XX +/--.03 [.8mm]		
(OTHER) .XX +/--.02 [.5mm]		
(ALL) .XXX +/--.005 [.13 mm]		
FRACTIONS +/-1/32 [.8 mm]		
ANGLES +/-1/2°		
First Angle Projection		
MATERIAL	FINISH	
DO NOT SCALE DRAWING	NAME	DATE
DRAWN	LCS	6-23-23



**PROPRIETARY AND CONFIDENTIAL**  
 This drawing is the property of Rev-A-Shelf LLC (RAS) and is disclosed in confidence to the extent its subject matter is original to RAS. Any vendor receiving this drawing from RAS shall hold and use this drawing for the sole benefit of RAS and shall not disclose it to, or use or reproduce it for any third party, or perform any act adverse to the interest of RAS with respect to this drawing without the express written permission of RAS. Vendors shall not revise any physical, dimensional or performance characteristic unless authorized by Rev-A-Shelf Engineering.

REV	DATE	BY	DESCRIPTION OF CHANGE

4

3

2

1

4

3

2

1

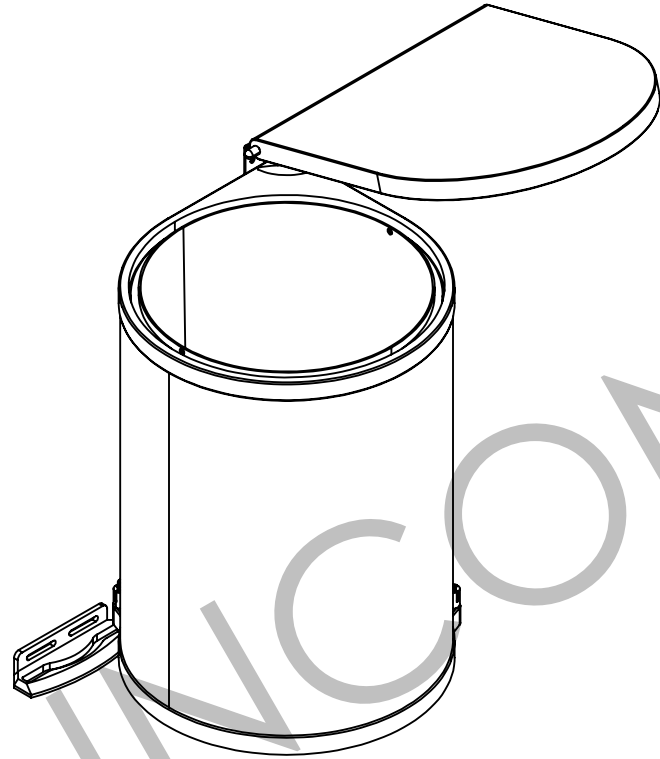
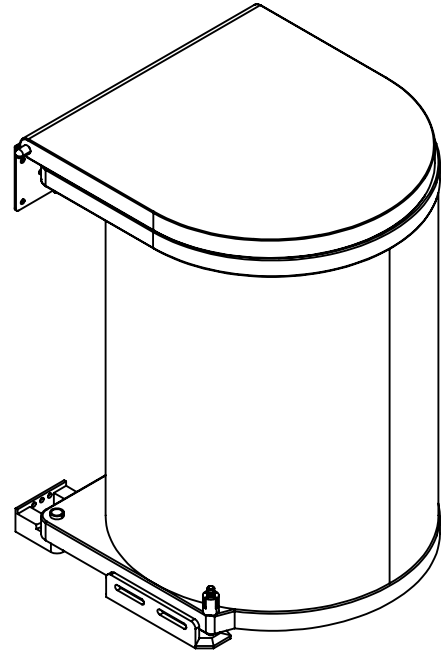

PART NO.	A	B	C	FINISH
8-010212-14	14.22 [361.16]	16.86 [428.08]	17.00 [431.8]	WHITE LACQUERED
8-010412-15	15.50 [393.74]	18.14 [460.65]	18.25 [463.55]	WHITE LACQUERED
8-010314-15	15.50 [393.74]	18.14 [460.65]	18.25 [463.55]	STAINLESS STEEL

PART DIMENSIONS	
WIDTH	11.56 [293.73]
DEPTH	10.87 [275.97]
HEIGHT	A
HEIGHT W/ LID OPEN	B

MIN CABINET OPENING				
	FACE FRAME	FRAMELESS	INSET FACE FRAME	INSET FRAMELESS
WIDTH	13.75 [349.25]	13.75 [349.25]	13.75 [349.25]	13.75 [349.25]
DEPTH	11.00 [279.4]	11.00 [279.4]	11.75 [298.45]	11.75 [298.45]
HEIGHT	C	C	C	C

CUSTOMER DRAWING

Description:  
**PIVOT OUT  
 WASTE CONTAINER**

PART NO. 8-010XXX-XX

SIZE **B** DWG. NO. 8-010XXX-XX\_CUST REV

SCALE: 1:6 WEIGHT: SHEET 2 OF 2

UNLESS OTHERWISE SPECIFIED:		
TOLERANCES = INCH/(MM)		
MAT. DEC.		
(WOOD) .XX +/- .03 [.8mm]		
(OTHER) .XX +/- .02 [.5mm]		
(ALL) .XXX +/- .005 [.13 mm]		
FRACTIONS +/- 1/32 [.8 mm]		
ANGLES +/- 1/2°		
First Angle Projection		
MATERIAL	FINISH	
DO NOT SCALE DRAWING	NAME	DATE
DRAWN	LCS	6-23-23



PROPRIETARY AND CONFIDENTIAL

This drawing is the property of Rev-A-Shelf LLC (RAS) and is disclosed in confidence to the extent its subject matter is original to RAS. Any vendor receiving this drawing from RAS shall hold and use this drawing for the sole benefit of RAS and shall not disclose it to, or use or reproduce it for any third party, or perform any act adverse to the interest of RAS with respect to this drawing without the express written permission of RAS. Vendors shall not revise any physical, dimensional or performance characteristic unless authorized by Rev-A-Shelf Engineering.

REV	DATE	BY	DESCRIPTION OF CHANGE

4

3

2

1

B

B

A

A