

SONDER

LIVING

LOUIS 4 DOOR SIDEBOARD

Thank you for choosing this quality product. Be sure to check all packaging materials carefully for small parts that may have loosened inside the carton during shipment and place on a non-abrasive surface.

IMPORTANT

These parts can be cumbersome and heavy to some people, therefore, the assistance of two or more people are recommended in order to prevent personal injury and ensure the furniture is not damaged during the assembly Process.

PART LIST

- A. [1] SIDEBOARD
- B. [2] REMOVABLE SHELF PANELS (LARGE)
- C. [2] REMOVABLE SHELF PANELS (SMALL)

INSTRUCTIONS

1. Fully open the middle drawer and then fully remove the silver tray from the drawer box. Refer to FIGURE 01.

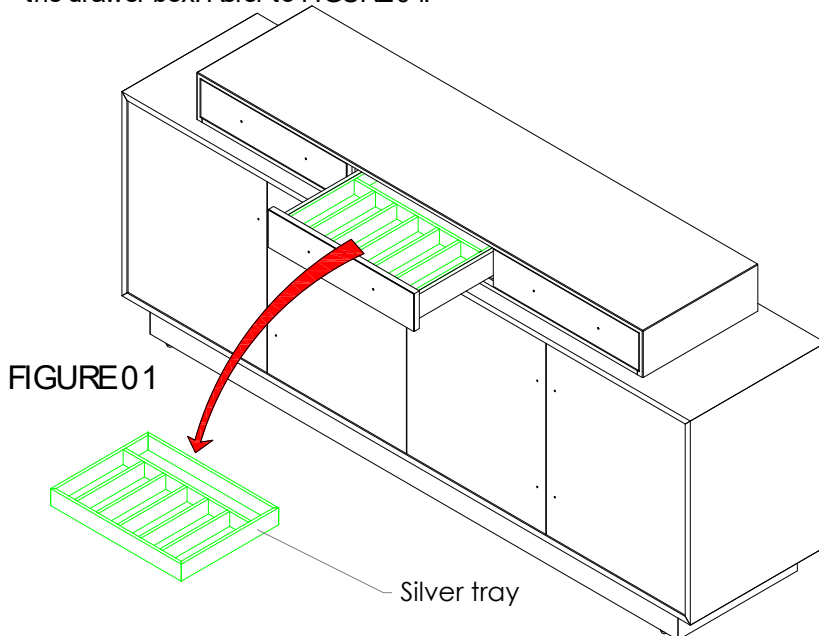

2. For packing purpose, the drawer handles were removed and put in hardware bag. Open the drawer and attach the handles (1) to the doors by using the Phillips head bolts (2) provided. Refer to FIGURE 02.
3. Repeat above step to attach handle for other drawers.

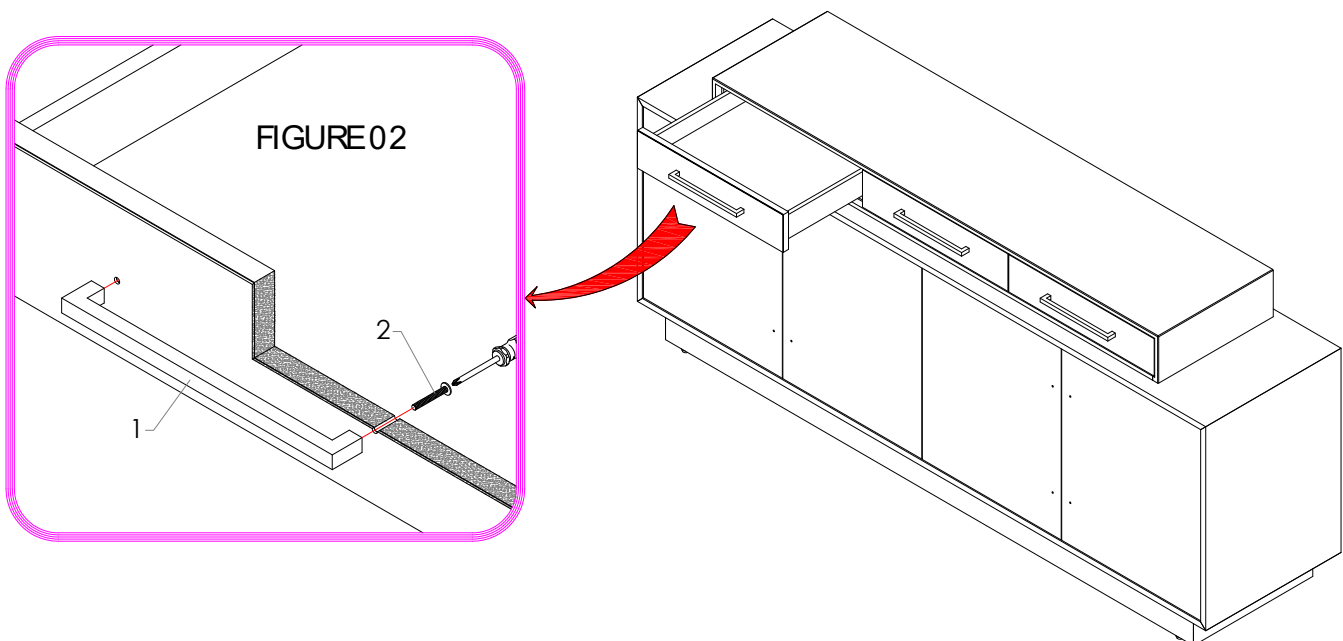

TOOLS NEEDED

Phillips Screwdriver (Not included)

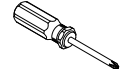

HARDWARE LIST

NO	DESCRIPTION	QTY
1	DRAWER HANDLE	3
2	PHILLIPS BOLT M4X30MM	6
3	DOOR HANDLE	4
4	PHILLIPS BOLT M4X25MM	8
5	SHELF HOLDER	16
6	SCREW	16
7	METAL BRACKET	2
8	CLEVIS PIN	2
9	STEEL AIRCRAFT CABLE	1
10	HAIRPIN	2
11	SHORT SCREW	2
12	LONG SCREW	2
13	TOGGLE BOLT	2

4. For packing purpose, the door handles were removed and put in hardware bag. Open the door and attach the handles (3) to the doors by using the Phillips head bolts (4) provided. Refer to FIGURE 03.
5. Repeat above step to attach handle for other doors.
6. Install the shelf holders (5) and place the shelf panels (B/ C) on the shelf holders. Fix the shelf panels to the shelf holders by using screws (6) provided. See FIGURE 04.
7. Set up the silver tray for the furniture. NOTE: The silver tray can install with all drawer according to your desired. Refer to FIGURE 05.
8. Check the furniture leveling, if it does not seat level, adjust the leveler on the bottom of the leg, as per illustrated in FIGURE 06.

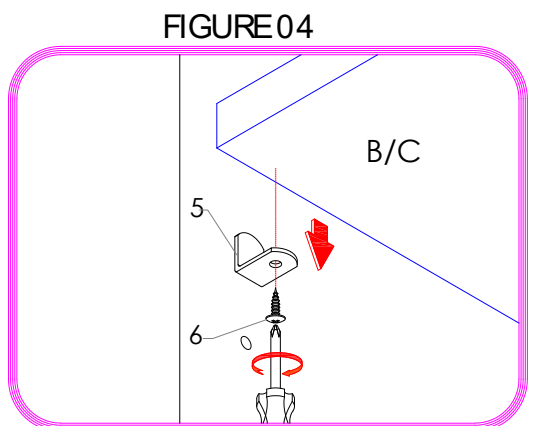
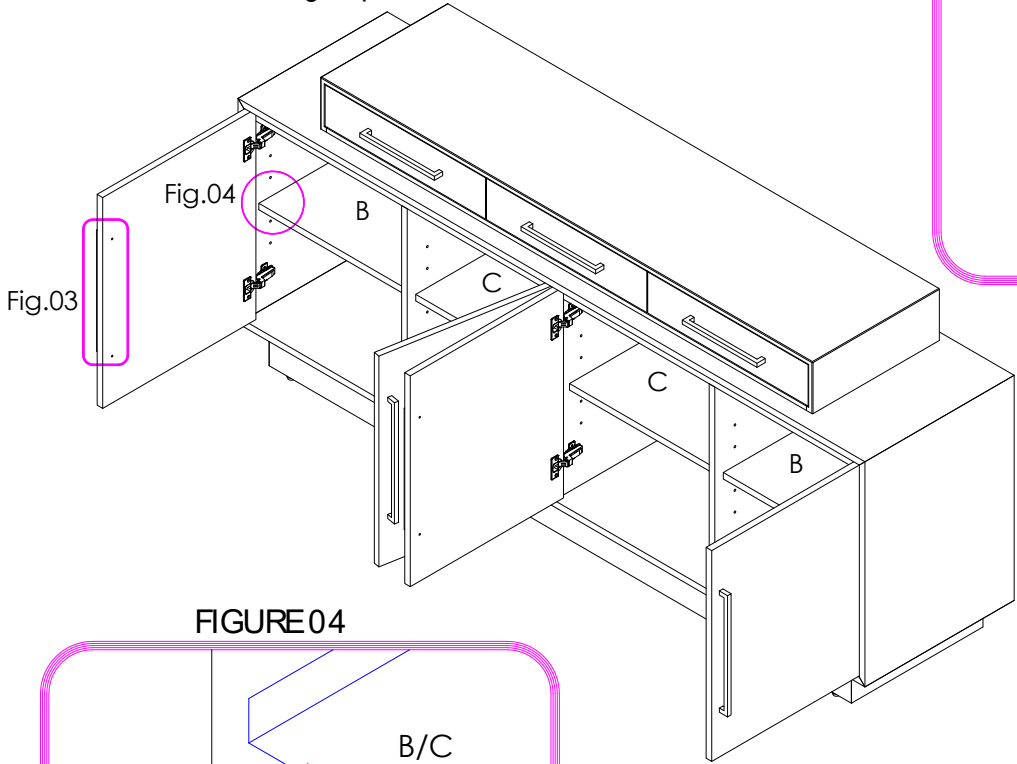
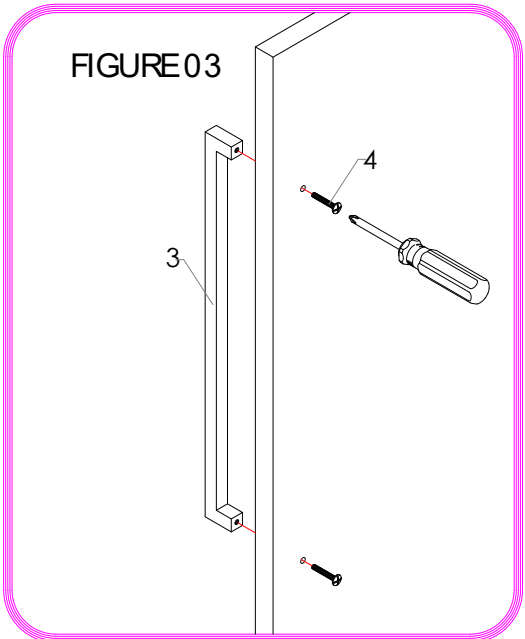

ASSEMBLY INSTRUCTIONS BY WALL TYPE:

- **DRYWALL WITH STUDS:** Use screws to affix to studs, and use hollow wall anchors and screws to affix to drywall. See FIGURE A.
- **DRYWALL WITHOUT STUDS:** Use toggle bolt and screws to affix to drywall. See FIGURE B.

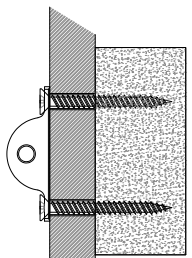

FIGURE A
DRYWALL W/STUDS

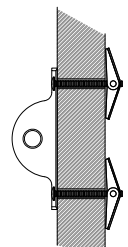

FIGURE B
DRYWALL W/O STUDS

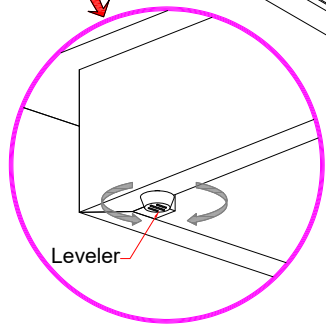
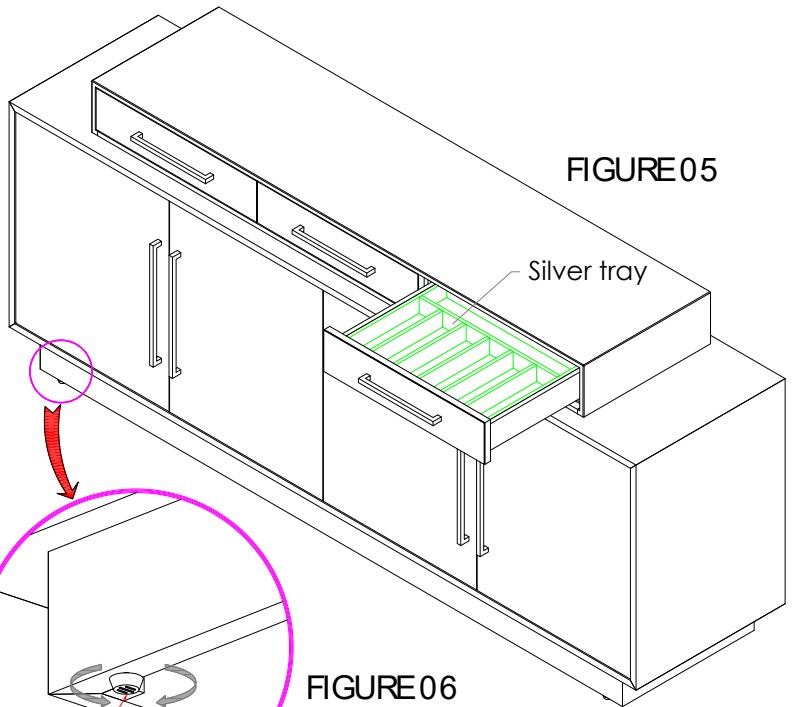

FIGURE 06

FURNITURE TIPPING RESTRAINT INSTRUCTIONS

Young children may be injured by tipping furniture. The use of a tipping restraint is highly recommended.

When properly installed, this restraint could provide protection against the unexpected tipping of furniture due to small tremors, bumps or climbing. We recommend mounting this restraint to a wall stud.

WARNING: This product is only a deterrent. It is not a substitute for proper adult supervision.

ANTI-TIP-KIT INSTALLATION INSTRUCTION

⚠ WARNING: Always mount metal brackets to solid wood of furniture. Do not attach to plywood of back panels. **WERECOMMEND ATTACHING TO STUDS.**

1. Attach mounting brackets (7) near the middle-top back edge of the furniture piece by inserting the shorter screws (11).
2. Determine the final position of the furniture piece. Mark locations on the wall approximately 2" below the brackets mounted to the back of the furniture.
3. Attach the second brackets to stud wall by inserting the longer screw (12) (See Figure A) or toggle bolt (13) with drywall (See Figure B).
4. Place the furniture so that the brackets on the back edge are in line with the brackets in the wall.
5. Insert the clevis pin (8) through holes on brackets and hole on steel aircraft cable (9). Use hair pin (10) to go through small hole on clevis pin (8) to lock it.
6. Repeat above step to attach the end of aircraft cable (9) to the bracket on the wall.
7. Check to make sure the steel aircraft cable is securely laced and locked to the brackets.

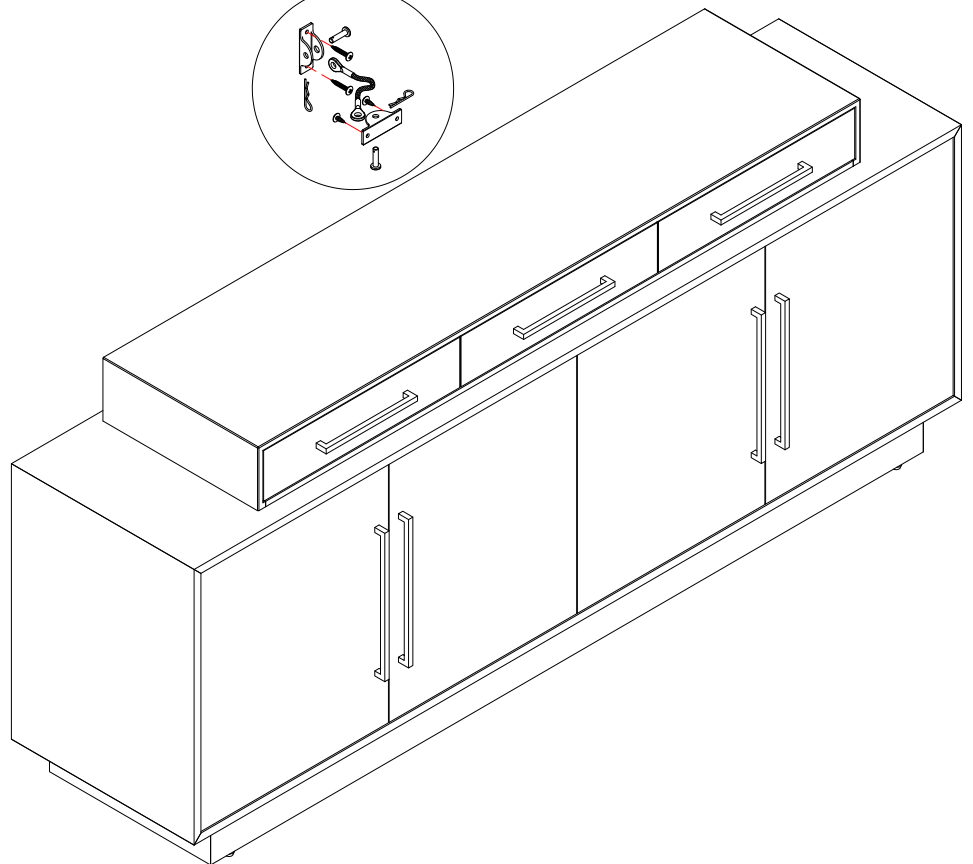
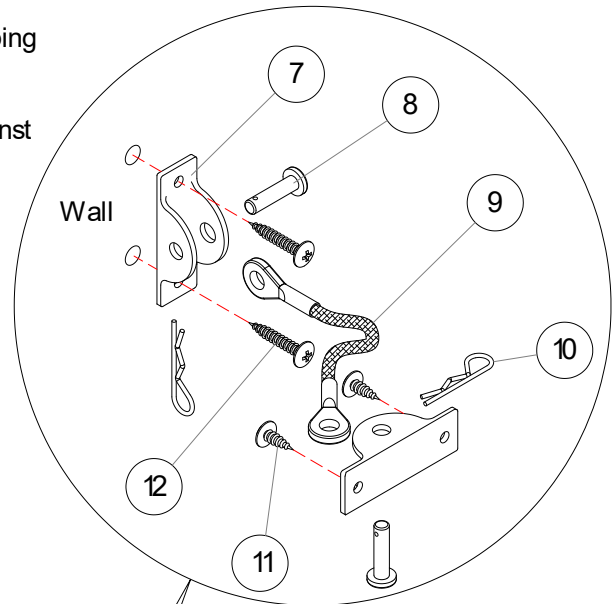

CARE INSTRUCTIONS

1. Dust often using a clean, soft, dry and lint-free cloth.
2. Blot spills immediately and wipe with a clean, damp, cloth.
3. We do not recommend the use of chemical cleansers, abrasives or furniture polish on our lacquered finish.

IMPORTANT SAFETY INSTRUCTIONS

1. Please read all instructions carefully before assembling.
2. Keep instructions for future use.
3. Use only vendor supplied hardware to assemble. Using unauthorized hardware could jeopardize the structural integrity of the item.