

STC1515

High Speed Servo Motor Series



PUSHCORP
Manual

!CAUTION!

Do **NOT** apply air pressure to release the toolholder while the servo motor is rotating. The servo motor spindle must be **FULLY STOPPED** before actuating.

Do **NOT** overheat the servo motor. Supply the motor cooling water to maintain a temperature below 212 °F (100 °C).

Do **NOT** start or stop the servo motor instantaneously. Doing so will damage the motor and power amplifier.

All *PushCorp* electrical cables are rated for high twist and flex robotic applications with a minimum cable bending radius specification of 125mm (5 in). Cable damage resulting from failure to abide by this specification will not be covered under warranty.

Do **NOT** use safety rated IO. These pulse at an extremely high rate and the servo amplifier will turn off the IO as a result.

Table of Contents

- 1.0 Limited Warranty 1**
- 2.0 GENERAL OVERVIEW 3**
- 3.0 INSTALLATION 4**
 - 3.1 Mounting the STC1015..... 4**
 - 3.1.1 Mounting to AFD310/70: Parallel Configuration 4
 - 3.1.2 Mounting to AFD310/70: Perpendicular Configuration..... 6
 - 3.2 Toolholder Specification 7**
 - 3.3 Pneumatic Connection 9**
 - 3.4 Electrical Connections 11**
 - 3.4.1 AKD2G Servo Amplifier – Default Electrical Connections..... 11
 - 3.4.2 S724 Servo Amplifier – Default Electrical Connections 12
 - 3.4.3 Resolver Motor Timing Chart 13
 - 3.5 Motor Cooling 14**
 - 3.6 Position Motor Shaft for Tool Change 15**
 - 3.7 Resolver Motor Timing Chart 15**
- 4.0 TECHNICAL SPECIFICATIONS 18**
- 5.0 PREVENTATIVE MAINTENANCE SCHEDULE 19**

1.0 Limited Warranty

Duration:

One year from date of delivery to the original purchaser.

Who gives this warranty:

PushCorp
Telephone: (972) 840-0208

Corporate Address:
P.O. Box 181915
Dallas, Texas 75218

Shipping Address:
3001 W Kingsley Rd
Garland, Texas 75041

Who gives this warranty (purchaser):

The original purchaser (other than for purposes of resale) of the *PushCorp* product

What products are covered by this warranty:

Any *PushCorp* industrial equipment or accessory supplied or manufactured by the Warrantor.

What is covered under this warranty:

Defects in material and/or workmanship which occur within the duration of the warranty period

What is not covered in this warranty:

- a) IMPLIED WARRANTIES, INCLUDING THOSE OF MERCHANTABILITY AND FITNESS FOR A PARTICULAR PURPOSE ARE LIMITED TO ONE YEAR FROM THE DATE OF ORIGINAL PURCHASE. Some states do not allow limitations on how long an implied warranty lasts, so the above limitations may not apply to you.
- b) ANY INCIDENTAL, INDIRECT, OR CONSEQUENTIAL LOSS, DAMAGE or EXPENSE THAT MAY RESULT FROM ANY DEFECT, FAILURE, MALFUNCTION OF THE *PUSHCORP, INC.* PRODUCT. Some states do not allow the exclusion or limitation of incidental or consequential damages so the above limitation or exclusion may not apply to you.
- c) Any failure that results from an accident, purchaser's abuse, neglect, unauthorized repair or failure to operate the products in accordance with the instructions provided in the owner's manual(s) supplied with the product.

Responsibilities of the Warrantor under this warranty:

Repair or replace, at Warrantor's option, products or components which have failed within the duration of the warranty period.

Responsibilities of the purchaser under this warranty:

- a) Deliver or ship the *PushCorp* product or component to PushCorp Service Center, Dallas, TX. Freight and insurance costs, if any, must be borne by the purchaser.
- b) Use reasonable care in the operation and maintenance of the product as described in the owner's manual(s).

When warrantor will perform repair or replacement under this warranty:

Repair or replacement will be scheduled and serviced according to the normal workflow at the service center and depending on the availability of replacement parts. Purchasers requiring quicker repair may receive such with payment of a *PushCorp* predetermined expediting fee.

This Limited Warranty gives you specific legal rights and you may also have other rights which vary from state to state.

2.0 GENERAL OVERVIEW

The *PushCorp, Inc.* STC1515 High Torque Servo Toolholder provides a convenient and effective means to spin and change many different media types. The unit incorporates a 15 horsepower (11.2 kW) Servo Motor to provide high torque and precise speed control from 0 to 15,000 RPM. The pneumatically actuated BT30 toolholder allows a quick change of media or tooling to support a fully automated workcell.

The STC1515 is comprised of five primary components: a high-torque Servo Motor, a 30 tapered & keyed shaft, a pneumatic actuator, high force Bellville springs, and a retention knob gripper assembly. The motor shaft is designed to accept a standard BT30 toolholder. Since the motor shaft is keyed and the toolholder has corresponding slots, they must be indexed to a known position before a tool change can occur. High force Bellville springs located at the back of the Motor Housing tension a draw bar, which pulls the gripper and locks the toolholder in the shaft. Energizing the large pneumatic actuator, located in the Clamping Housing opens the gripper assembly and releases the toolholder.

The STC1515 has several clever design features, which make it unique. First it is fail-safe in that no air pressure is required to secure the toolholder. Therefore the toolholder will remain held in the motor shaft even when the air pressure is unexpectedly lost. Likewise, applying air pressure to a single input port via a simple manual or electrically operated valve opens the retention knob gripper and releases the toolholder from the motor shaft. Finally, this mechanical design isolates the bearings from the drawbar tension. This greatly improves reliability by allowing the motor shaft to never be subjected to any clamping forces. The STC1515 has sealed duplex spindle bearings to insure a long life and very low runout. The front bearings have additional contamination protection from a PushCorp proprietary shaft labyrinth seal, as well as a purge located in the front end cap. It is recommended that this purge is supplied with 55-60 PSI at 1 SCFM.

During operation the STC1515 generates considerable heat due to the high torque capability and compact size. Excessive operating temperatures will significantly reduce the life of the motor. The motor should never be allowed to exceed a temperature of 212 °F (100 °C). Continuously operating the unit above this value will cause the rotor to de-magnetize and the bearings to fail. High temperatures will also cause the O-rings that seal the cooling water to fail. PushCorp has provided flow through cooling on the motor to allow high duty cycles without overheating.

Simple reliable construction combined with high torque and precision speed controlled servo technology make the *PushCorp* STC1515 Servo Tool Changer a rugged, state-of-the-art technology capable of providing flexible, cost-effective tool changing operations.

3.0 INSTALLATION

3.1 Mounting the STC1015

3.1.1 Mounting to AFD310/70: Parallel Configuration

The STC1515 Servo Tool Changer is designed to attach to the Carriage of a *PushCorp* AFD1100/80 Force Device. There are two standard attachment options.

For the Parallel-Axis configuration, shown in Figure 1, the 1515 attaches to the AFD Carriage with two brackets and four (4), M8x1.25x25mm, Socket Head Cap Screws. The 1515 is positioned on the Carriage with the Foot Bracket while the Front Bracket is attached to the forward mounting holes. The Clamping Screw on the Front Bracket should be loose to allow sliding movement along the motor. Attach the Foot Bracket to the Clamping Housing (Mounting Plate for the SM0612) using two (2), M8x1.25 Socket Head Cap Screws. When the desired position is achieved secure the brackets to the Carriage, and tighten the Clamping Screw. The M8x1.25, Socket Head Cap Screws, must be the proper length and tightened to the torque specified in Section 4.0.

To attach the STC1515 to an AFD in a Perpendicular-Axis configuration, position the Clamping Housing over the Carriage as shown in Figure 2. Then secure the unit using four (4), M8x1.25x180mm, Socket Head Cap Screws. Tighten the fasteners to the torque specified in Section 4.0.

CAUTION: Make sure that the M8x1.25x20 fasteners do not exceed a depth of 0.52" (13.3 mm) into the AFD Carriage Helicoils or damage will occur.

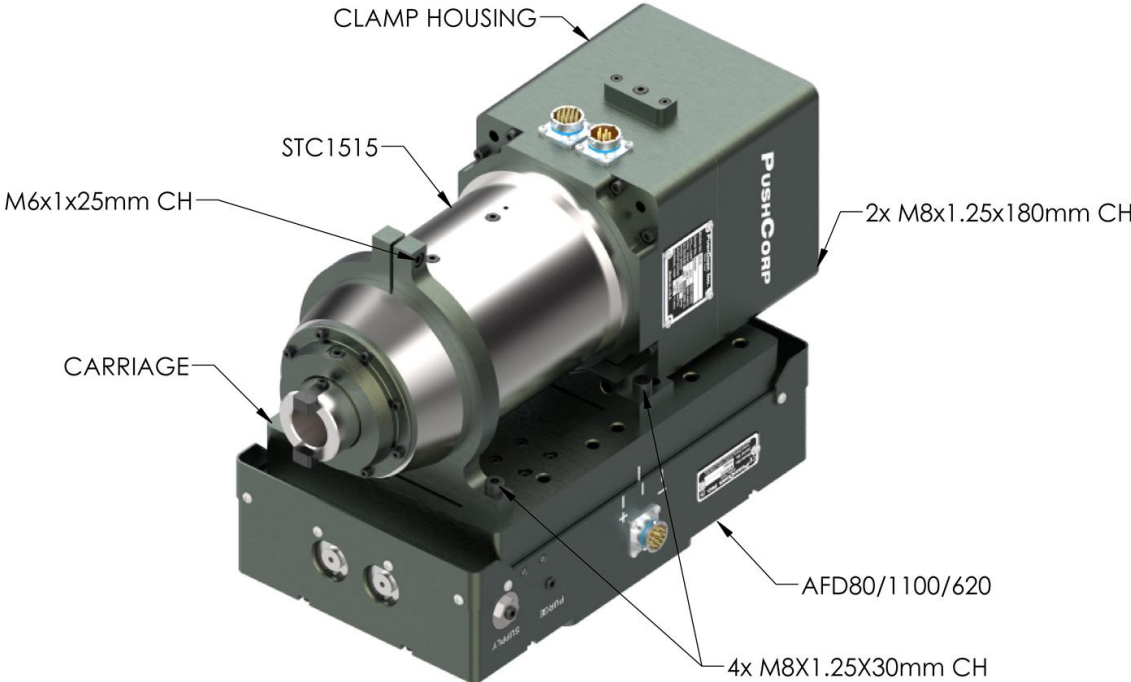

FIGURE 1: STC1515 PARALLEL-AXIS CONFIGURATION

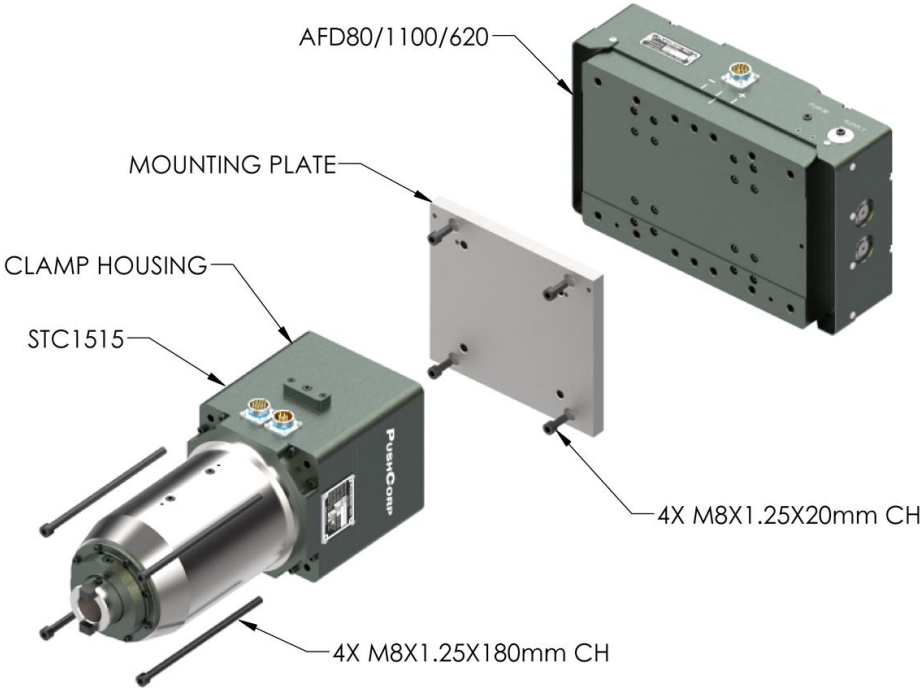

FIGURE 2: STC1515 PERPENDICULAR-AXIS CONFIGURATION

3.1.2 Mounting to AFD310/70: Perpendicular Configuration

For some processes compliance and force control are not required. The STC1515 can be mounted directly to the robot and the system can be operated in position mode. This robotic system is equivalent to a 6-axis machining center with a very large work volume and lower positional accuracy. Certain product types and processes are well suited for a Robotic Machining Center (RMC).

The STC1515 can be attached to the robot mounting flange using a mounting plate. For direct mounting it is recommended that a breakaway clutch be installed. The breakaway clutch will help protect the motor in the event of a robot crash.

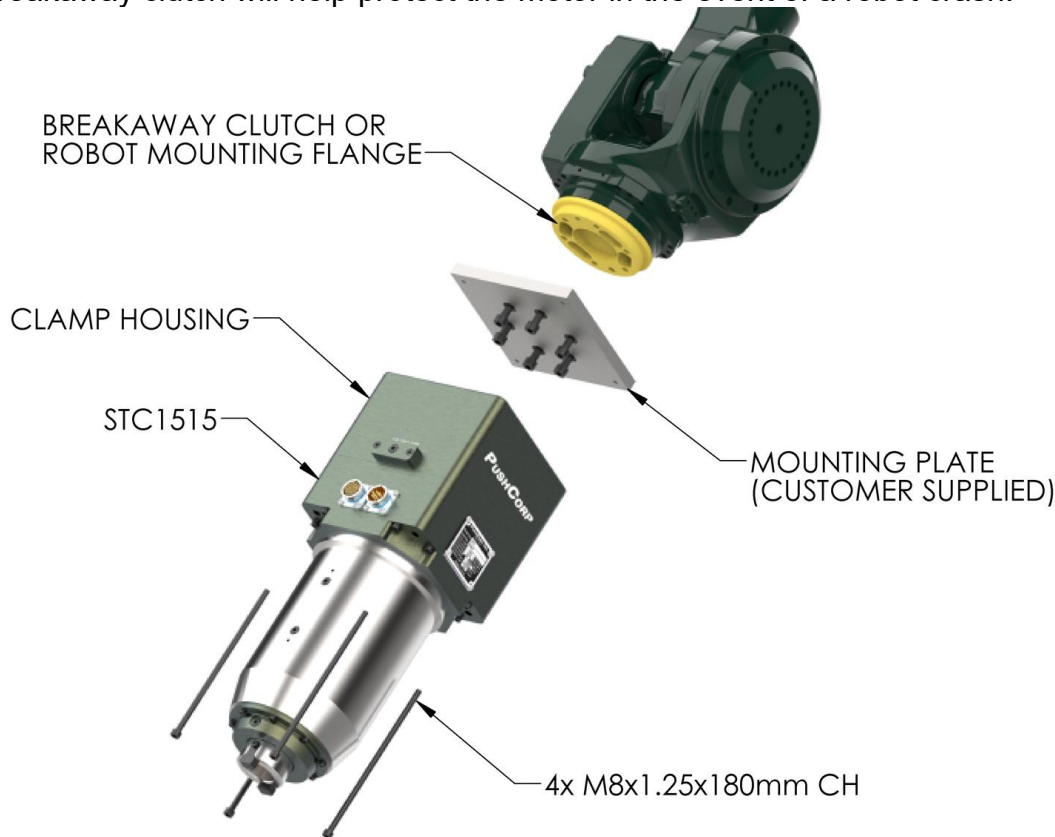

FIGURE 3: STC1515 DIRECT MOUNTING

To mount the STC1515, first attach the Mounting Plate to the Robot Mounting Flange or to the Breakaway Clutch, per the manufacturer’s specifications. Once the Mounting Plate is secured, place the STC1515 against the Mounting Plate and install (4) four, M8x1.25X180mm, Socket Head Cap Screws. (See Figure 3) Tighten the fasteners to the torque specified in Section 4.0.

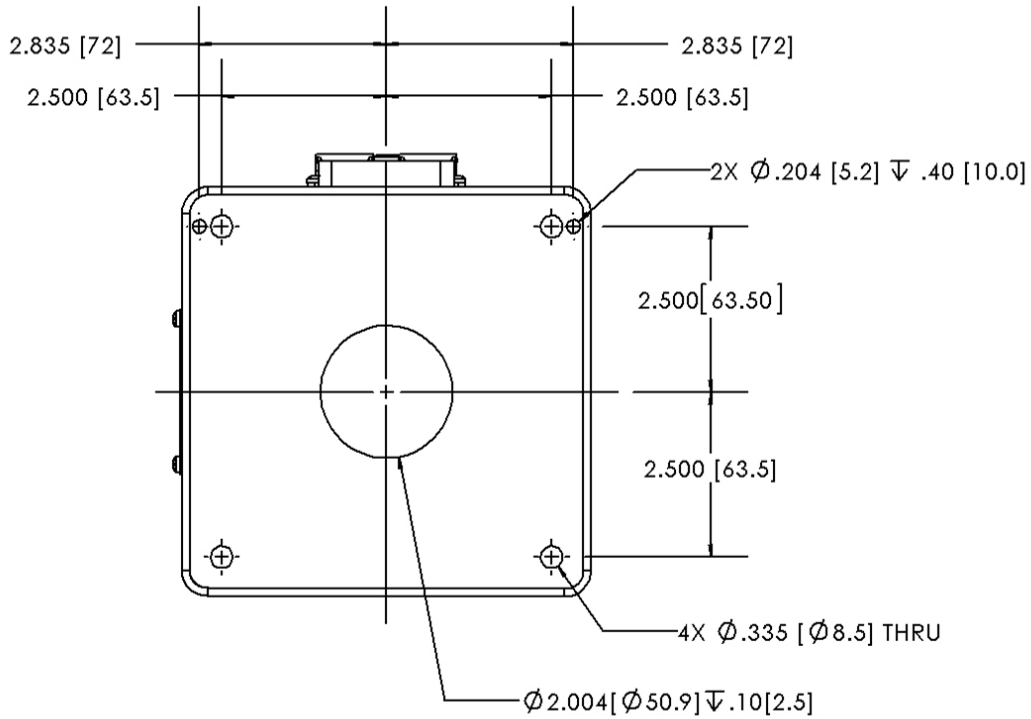

FIGURE 4: STC1515 MOUNTING DIMENSIONS

3.2 Toolholder Specification

The STC1515 is designed to grip a BT30 toolholder. The BT30 toolholder is a standard machine tool style and may be purchased from several sources including, MSC (www.msc.com), and J & L Industrial Supply (www.jlindustrial.com). The Customer can also make their own BT30 toolholder to handle special media (See Figure 5 for toolholder dimensions). The toolholder must be equipped with a Parlec (www.parlec.com) retention knob, part number 3003TRK, or equivalent. Figure 6 shows the Parlec retention knob with the required dimensions.

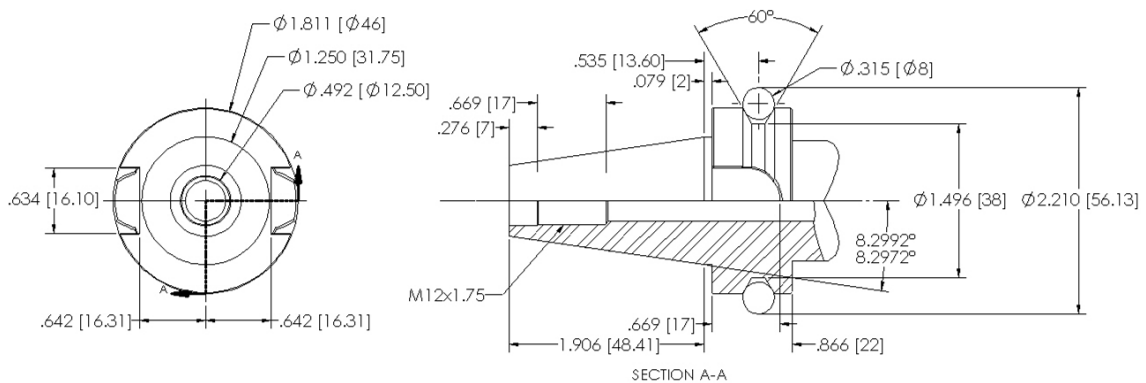

FIGURE 5: TOOLHOLDER DIMENSIONS

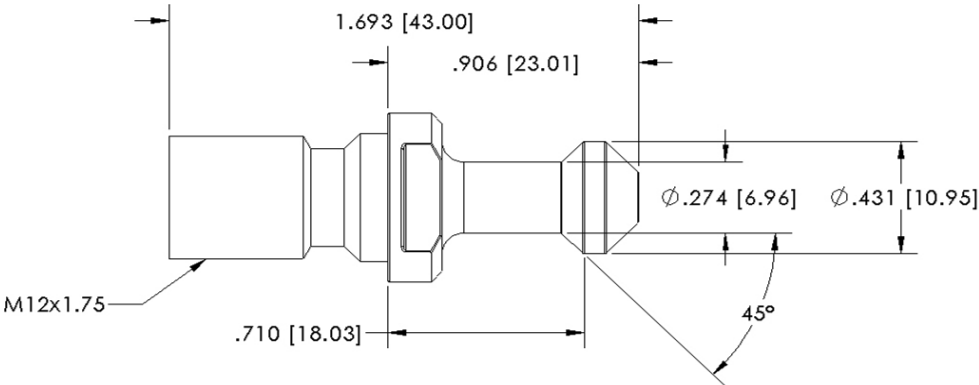

FIGURE 6: STC1515 RETENTION KNOB

3.3 Pneumatic Connection

The STC1515 Servo Tool Changer requires a dry, non-lubricated, filtered air supply, with a minimum pressure of 90 psi (6.2 bar) and a maximum pressure of 100 psi (6.9 bar). Failure to provide supply air to these specifications can degrade performance and will void any warranty repairs concerning pneumatic components. If the supply air pressure is too low then the STC1515 will be unable to open the retention knob gripper fully. Not opening the retention knob gripper fully will not allow a toolholder to be clamped or released. Exceeding the maximum air pressure could result in permanent damage to the STC.

The pneumatic supply system should be configured as shown in Figure 7. A manual or electrically operated valve may be used to energize the STC1515 for toolholder release, but the valve must exhaust **ALL** line pressure when unenergized. An electrically operated pneumatic valve is normally used in an automated work cell. PushCorp highly recommends the installation of a Pressure Switch in the Supply Line to the STC1515. This switch should not allow the STC1515 to start if there is any pressure in the Supply Line. Pressure in the line will cause internal components to come into contact. This will either cause the motor not to spin, or cause very high internal friction, eventually friction welding components together.

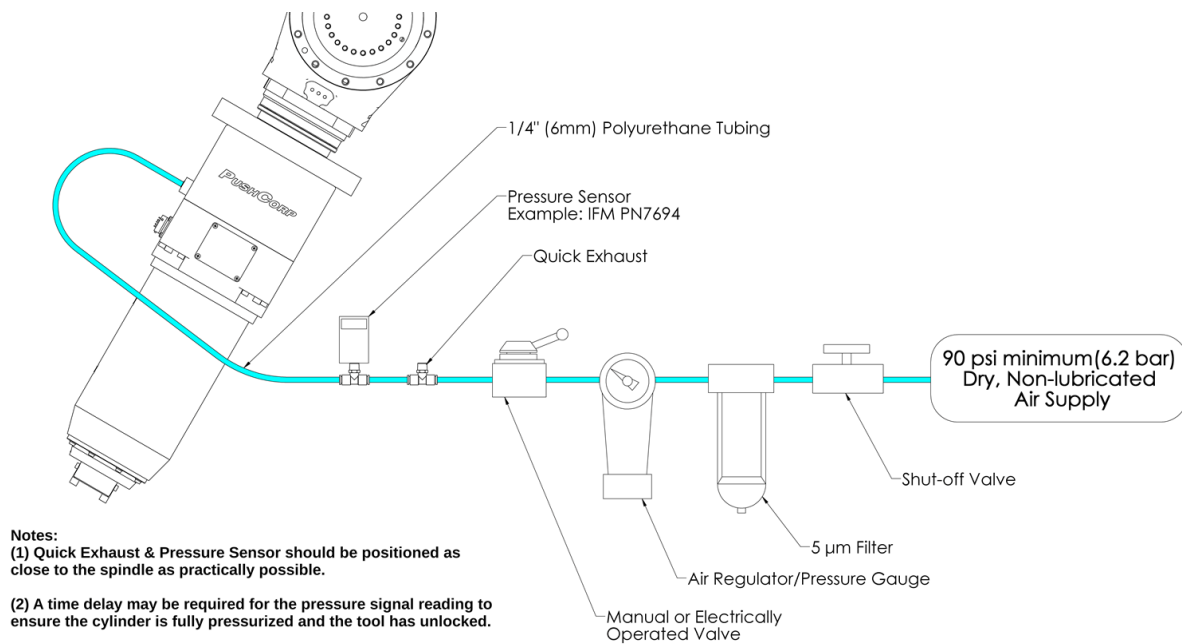

FIGURE 7: PNEUMATIC CONNECTIONS

The STC1515 is provided with ¼ inch and 6 mm diameter tubing push-lock fittings for installation in the R 1/8 (Metric) Unclamp Port located on the top of the Clamping Housing (See Figure 8). Remove the shipping plug and install the desired size push-lock fitting. If another type of fitting is desired, unscrew the existing fitting and replace it

with any fitting having an R 1/8 (Metric) thread. Be sure to use a thread seal product and do not over tighten the fitting.

The Supply Line to the device should be 1/4 inch or 6 mm diameter flexible polyurethane tubing. The tubing should be routed to the device such that there are no kinks and that there is plenty of slack to allow for manipulator motion. Before inserting the tubing into the STC1515 air fitting, open the Shut-Off Valve to blow out any contaminants which may be in the Supply Line. The tubing can now be pushed into the self-locking fitting located on the Clamping Housing as shown in Figure 8. Charge the Supply Line with compressed air and verify that there are no air leaks and that there is a minimum of 90 PSI (6.2 bar) at the STC1515. If a minimum air pressure cannot be achieved, then an auxiliary air compressor or booster pump must be installed.

NOTE: PushCorp highly recommends the use of flexible polyurethane tubing as opposed to nylon tubing. This is because nylon tubing tends to crimp shut when it is bent.

To remove the Supply Line for service, first discharge air pressure in the STC1515, then while pushing inward on the fitting's plastic ring, simultaneously pull the tubing out. Cover or plug the self-locking fitting any time the Supply Line is not connected. This will keep contaminants from entering the STC1515.

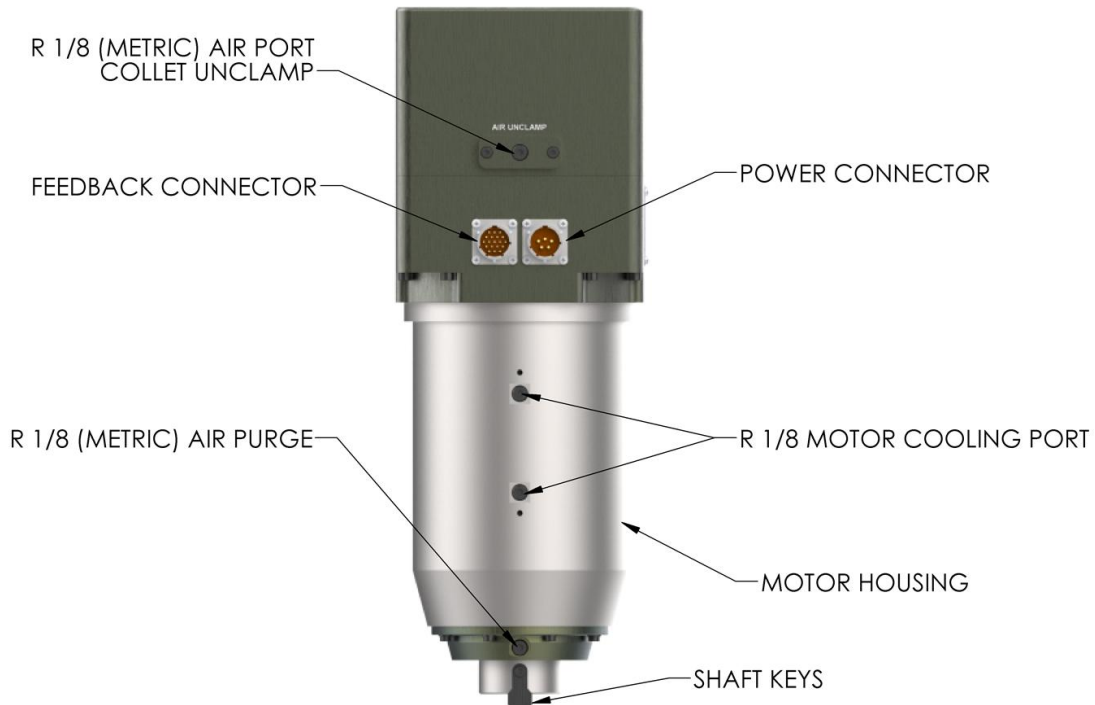

FIGURE 8: STC1515 EXTERNAL CONNECTIONS

3.4 Electrical Connections

The STC1515 has two electrical connections, the Motor Power and Motor Feedback (See Figure 8). If PushCorp supplies the cables and amplifier the tool should be easily connected to the amplifier.

CAUTION: Do not run the Motor Power Cable together with any feedback or control cables because of possible noise problems.

3.4.1 AKD2G Servo Amplifier – Default Electrical Connections

This amplifier is already properly configured for a PushCorp spindle. No further configuration is required if the below settings will work for your application.

Analog Interface

Connector	Pin	Function
X21	A1	Analog-In 1+ : +/-10VDC Command Velocity
X21	A2	Analog-In 1- : +/-10VDC Command Velocity
X21	B1	Analog-Out 1 : 0 - 10VDC Velocity Monitor
X21	B2	AGND : Analog GND

Digital Interface

Connector	Pin	Function
X21	A3	Digital-In 1 : Fault Reset Input
X21	A4	Digital-In 2 : Run Input
X21	A5	Enable : Enable Drive Input
X21	A6	Digital-in 3: Move to Tool Change Position
X21	B3	+24VDC : Digital Output Supply
X21	B4	DGND : Digital I/O Common
X21	B5	BTB/RTO : Ready To Operation (Dry Contact)
X21	B6	BTB/RTO : Ready To Operation (Dry Contact)
X21	B7	Digital-Out 1 : Motor Overload Warning
X21	B8	Digital-Out 2: At Tool Change Position
X21	A11	STO-A-A1 : Safety Torque Off A Input
X21	B11	STO-B-A1 : Safety Torque Off B Input

For more information an instruction manual is available at:

[AKD2G-instruction-manual.pdf](#)

3.4.2 S724 Servo Amplifier – Default Electrical Connections

This amplifier is already properly configured for a PushCorp spindle. No further configuration is required if the below settings will work for your application.

Analog Velocity Mode

+/-10VDC Analog Input for command velocity

Analog Interface

Connector	Pin	Function
X3B	9	-Analog-In 1 – Command Velocity
X3B	10	+Analog-In 1 – Command Velocity
X3B	13	AGND - Shield

Digital Interface

Connector	Pin	Function
X3A	1	Enable – Enable Drive Output
X3A	2	Digital-In 1 – Spindle ON/OFF
X3A	3	Digital-In 2 – Reset Fault
X3A	4	Digital-In 3 – Move to Tool Change Position
X3A	6	Digital-Out 1 – At Tool Change Position
X3A	7	Digital-Out 2 – At Zero Speed
X3B	14	BTB/RTO – Ready To Operation (Dry Contact)
X3B	15	BTB/RTO – Ready To Operation (Dry Contact)
X3B	16	DGND – Digital 0VDC Common

Optional Analog Output (MUST HAVE ANALOG CARD INSTALLED IN SLOT 3)

Connector	Pin	Function
X3C	17	Analog Out 1 - Velocity Feedback
X3C	18	AGND
X3X	19	Analog Out 2 - Motor Load Feedback
X3C	20	AGND

For more information an instruction manual is available at:

[S724-instruction-manual.pdf](#)

For all other questions please contact:

PushCorp Tech Support: 1.972.840.0208, 8am – 5pm Central Time

Kollmorgen Tech Support: 1.540.633.3545, 8am – 5pm Eastern Time

3.4.3 Resolver Motor Timing Chart

S724 – Resolver Motors
Error Reset, Servo ON/OFF, and Homing for Tool Change **PUSHCORP**

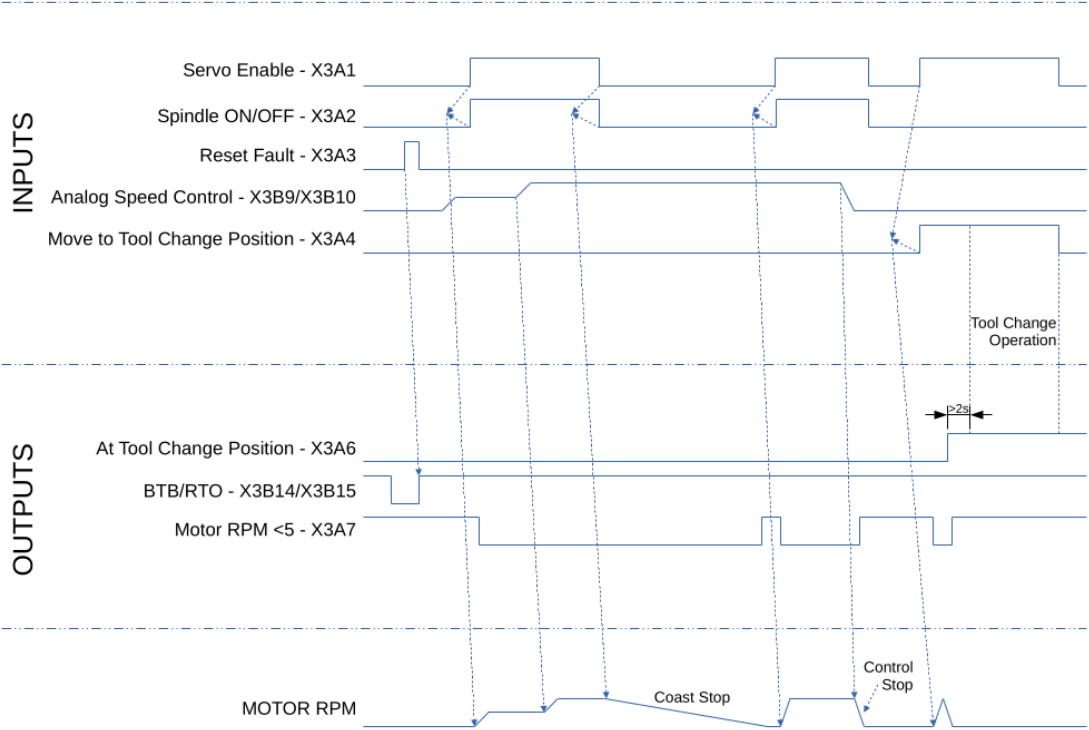

FIGURE 9: RESOLVER MOTOR INPUT/OUTPUT

3.5 Motor Cooling

The STC1515 has a compact, high torque, 15 Hp (11.2 kW) Servo Motor which requires water cooling. The motor is designed to operate below a temperature of 212 °F (100 °C). The optimal motor temperature range is 140 – 176 °F (60 – 80 °C). The STC1515 contains cooling channels in the Motor Housing surrounding the motor stator. These channels allow efficient removal of the heat. The coolant enters and exits the Motor Housing through two Motor Cooling Ports as shown in Figure 8. Either of these Motor Cooling Ports can be used as an input, the other would then become an output.

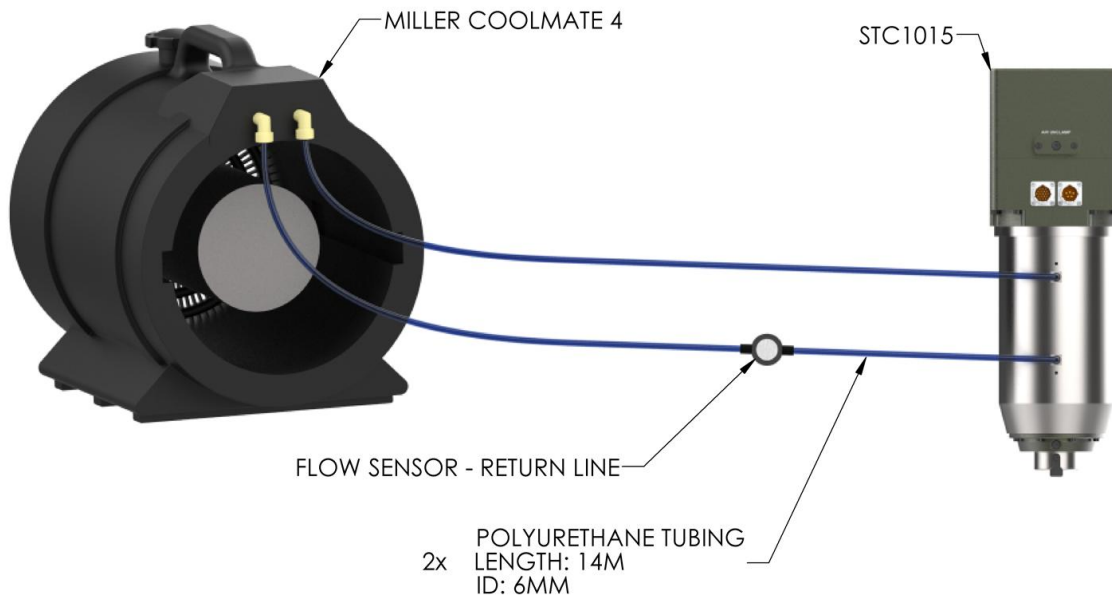

FIGURE 10: SPINDLE COOLING WITH COOLING UNIT

A closed-loop water cooling system must be used and requires a separate cooling unit per spindle that circulates water through the Motor Housing to remove the heat. Typical cooling units are comprised of a pump, liquid to air heat exchange, and a fan. These units are commercially available from several manufacturers (e.g. Miller Coolmate 4, www.millerwelds.com). The cooling unit should be sized based on the motor power output of the motor being used with an overall motor efficiency of 90% and the motor load conditions. See section 4.0 of this manual for motor output ratings for the motor being used. In the case of a closed-loop water cooling system, all of the coolant is recirculated in the system, and no continuous supply of discharge is required. Our standard offering is the Miller Coolmate 4, which you can see in Figure 10, PCI PN PAR04922. In this case the return line is the bottom connection; it is recommended that a flow sensor is installed inline with this port and wired back as part of the control circuit. PushCorp recommends the IFM flow sensor (PN SBG12IF0FRKG). This will ensure the coolant is circulating completely through the motor and back to the cooler. Domestically, PushCorp provides Miller’s pre-mixed glycol base aluminum protecting coolant (Miller PN 043-809 – PCI PN PAR04028). Any coolant which matches the parameters of this coolant may be used.

NOTE: Connecting two motors to a single Coolmate could yield inadequate cooling and reduce the life of the servo unit. The life of the motor is directly related to the operational temperature, so proper cooling is critical.

Again, it is recommended to constantly monitor the motor temperature during operation to ensure that it does not overheat. In addition, PushCorp recommends that one Miller Coolmate 4 (or equivalent) should be used per motor.

3.6 Position Motor Shaft for Tool Change

When performing a tool change the motor shaft must be clocked in the same position for drop-off and pick-up. The servo motor shaft has two keys (See Figure 8) that are spaced 180° apart and the BT30 toolholder has two corresponding key slots. The servo amplifier provides an input to clock the motor shaft in the proper position.

The keys are proper clocked when they are in line with the cooling ports and connectors as shown in Figure 11.

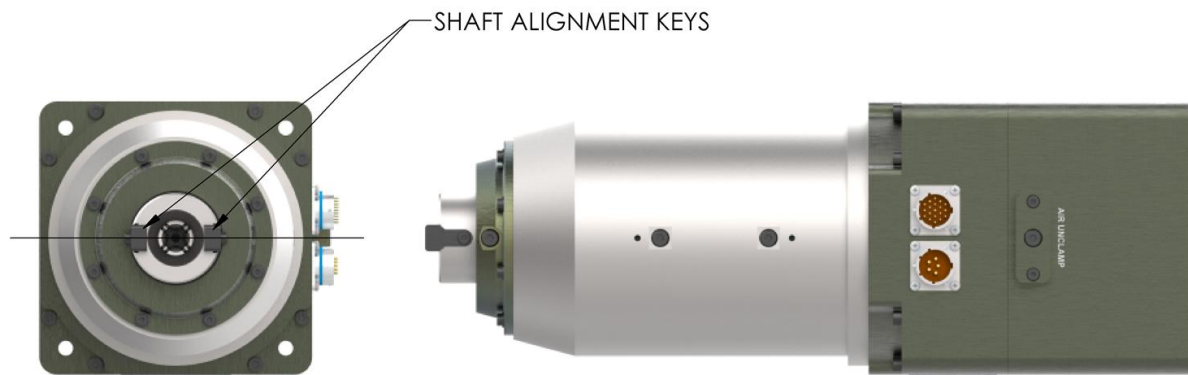

FIGURE 11: KEY CLOCKING ALIGNMENT

3.7 Resolver Motor Timing Chart

PushCorp STC spindles have the ability to switch tool holders out using pneumatic actuation. The STC1015 & STC1515 use a keyed BT30 toolholder, which provides strong holding torque and tool retention. To properly change out a tool, the following steps are recommended to avoid damaging the spindle, toolholder or gripper fingers.

Before Attempting Tool Change, Make Sure:

- Spindle is not rotating - Motor RPM < 5 feedback signal is ON
- If using retention knob not supplied by PushCorp, verify the dimensions match the illustration in section 3.2
- Make sure pressure does not remain supplied at the unclamp port for an extended period of time or this will result in damage to the spindle's pneumatic cylinder

Tool Change Sequence:

1. Clock the STC shaft to the appropriate position
2. Verify that the shaft & keys are clocked. Once clocked, there should be a >2second delay to ensure that the spindle is not spinning when making contact with the holder
3. Robot moves the end effector i.e. Servo Tool Changer (STC) to dock toolholder in the gripper/fingers/nest
4. Once fully docked, pressurize the "unclamp" port with at least 90 psi (6.2 bar) not to exceed 100 psi (6.9 bar).
5. Using a pressure sensor, such as IFM PN7694, verify that you have achieved at least 90 psi, again not to exceed 100 psi (refer to Figure 7 for connection set up)
6. Robot moves STC away from toolholder gripper/fingers/nest
7. Robot positions STC above the next tool holder
8. Confirm that the STC shaft is still clocked in the appropriate position
9. Robot moves STC toward the toolholder until the shaft and toolholder's tapers are fully seated against each other, then depressurize the "unclamp" port
10. Using a pressure switch that can sense below 0 psi such as the IFM PN7694, verify 0 psi (0 bar) at "unclamp" port
11. Robot moves out and away from gripper/fingers/nest removing the tool holder from the gripper/fingers/nest

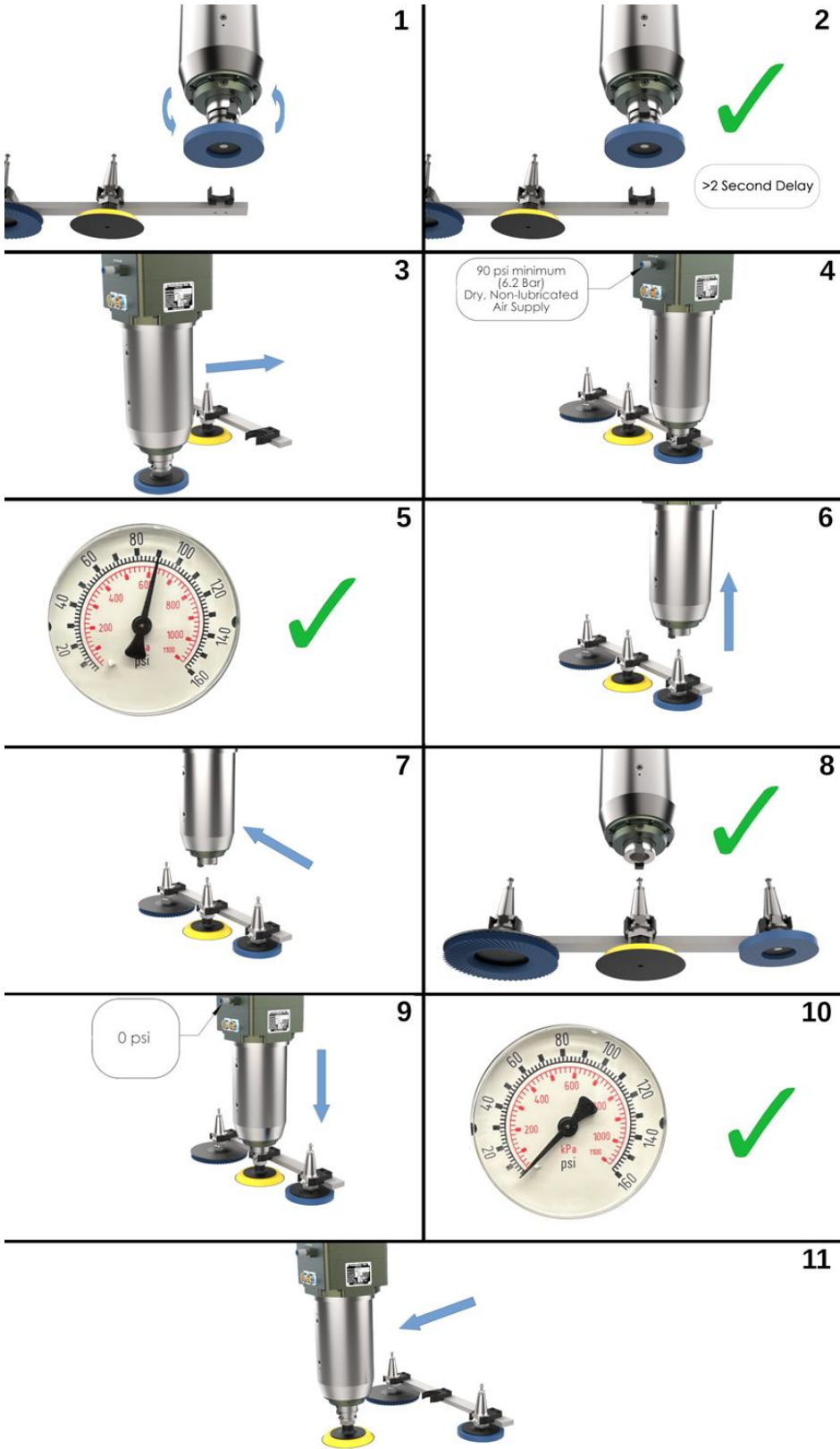

4.0 TECHNICAL SPECIFICATIONS

Category	Specification
Supply Voltage	480 VAC; 3 Phase +/-10%
Power	15.0 hp (11.2 kW)
Continuous Stall Torque	7.4 lb-ft (10 N-m)
Speed Range	0-15,000 RPM
Speed Regulation	2% (Reversible)
Weight	65 lb. (29.5 kg) Dry
Operating Temperature	Optimal: 122-176F (50-80C) Max: 212F (80C)
Max Coolant Pressure	60 psi (4.1 bar)

COLLET

Parameter	Value
Toolholder	BT30 standard
Retention Knob	Parlec #3003TRK, or equivalent

TORQUE SPECIFICATIONS:

Fastener Tightening Torque Specs					
Fastener Size	Torque			Minimum Depth	
	in.-lbs.	ft.-lbs.	N·m	in.	mm
M4 x .7	50	4.2	5.6	0.17	4.3
M5 x .8	85	7.1	9.6	0.21	5.3
M6 x 1	140	11.7	15.8	0.25	6.3
M8 x 1.25	348	29.0	39.3	0.33	8.4
M10 x 1.5	600	50.0	67.8	0.41	10.5

Specifications subject to change without notice.

5.0 PREVENTATIVE MAINTENANCE SCHEDULE

It is highly recommended to adhere to the preventative maintenance schedule in order help extend the longevity of the specified PushCorp, Inc. equipment. Failing to do so could cause a loss in functionality as well as a decrease in product life.

PUSHCORP, INC. SPINDLES			
Maintenance	Weekly	Monthly	3 Months
Wipe shaft (inside and out) and tool holders with a lint free cloth until clean and no debris remains. Use denatured alcohol if there is any grime or coatings.	X		
Remove debris from spindle/spindle housing.	X		
Check that the connectors are not bent/damaged.	X		
Check for flow in the motor cooling and unclamp ports.		X	

Agency/Organization: _____

Date Completed: _____